

# The Modular Design of Turn-milling CNC for Special Stones

Yuhou Wu<sup>\*1,2,a</sup> Dehong Zhao<sup>1,2,b</sup> Xuan Mu<sup>1,c</sup>

<sup>1</sup> School of Mechanical Engineering, Dalian University of Technology, Dalian, China

<sup>2</sup> College of Traffic & Mechanical Engineering, Shenyang Jianzhu University, Shenyang, China

\*Corresponding author, e-mail: yuhwu@sjzu.edu.cn<sup>a</sup>, jtjzdh@sina.com<sup>b</sup>, muxuan\_tgl@163.com<sup>c</sup>

## Abstract

Stone products' processing technologies, processes and types have essential differences with metal's, which makes the traditional machine design method, cannot perform well in the design of processing equipment for special shaped stones. A new design method was used in this paper, which through the establishment of stone typical products and tool mathematical model. The need of the motion axes was solved by kinematics equations application and the feasible design scheme of the machine tool's function was established. Thus, a new turn-milling combined NC machine tools, which have 8 movement axis and Double 5 axis linkage processing function is designed. Its modular structure design can meet the needs of the most stone material processing.

**Keywords:** motor function design, modular design, turn-milling CNC, special shaped stones.

**Copyright © 2013 Universitas Ahmad Dahlan. All rights reserved.**

## 1. Instruction

Movement function design is the most important content in the overall design of machine tools [1] Its purpose is to determine The number of machine's movement (the freedom), the nature of these freedom (linear motion or rotary motion), arrangement, form and order, which closely related to the course of working, Its pros and cons Of Movement function design, a key link in the overall program design [2] will directly affect the overall structure of the machine tools.

Special shaped stone products mainly curves, surfaces with high added value products, including basso-relievo, alien pillars, and sculptures etc, often requires multi-axis CNC machining system to complete [3] [4]. Stone as a hard and brittle materials, its processing technology, processes and types have essential differences with the metal's [6], makes use the traditional machine design method [5], which depends on the designer's experience or Traditional designs, can't Perform well in the design of the processing equipment for special shaped stones [7] [8].

In this paper,the author present the generative design method on numerical control machine movement function, breaking the traditional rely on designers experience or analogy method to determine the movement of the machine function scheme methods, which provide the theory basis for the innovation of the movement function for machine tool design, product innovation design [9] [10]. Guang Peng Zhang etc [11] discusses in detail about the generative method of the CNC movement function. But about the stone processing machine tool the generative method of the CNC movement function and the method have not been specific report. This paper based on stone products generative process and characteristics of a type Carved milling cutter and analyzes the demand of CNC movement function, and on that basis, there is proceeding design and development about a new milling CNC of special stone material.

## 2. Lathe Movement Function Analysis

The machining technics between stone material and common metal turning processing are very different. In order to ensure sufficient cutting linear velocity, stone material turning tools generally choose stone blades, rotating around a vertical axis.

1) The tool and work-piece mathematical model

According to turning processing characteristics, As shown in figure 1. The arbitrary manufacturing point on workpieces M in workpiece coordinate system  $O_w-X_wY_wZ_w$  is described as the matrix:

$$[{}^wT_m] = \begin{bmatrix} \cos \theta_{z_w} \cos \beta & -\sin \theta_{z_w} & \cos \theta_{z_w} \sin \beta & r \cos \theta_{z_w} \\ \sin \theta_{z_w} \cos \beta & \cos \theta_{z_w} & \sin \theta_{z_w} \sin \beta & r \sin \theta_{z_w} \\ -\sin \beta & 0 & \cos \beta & z \\ 0 & 0 & 0 & 1 \end{bmatrix} \tag{1}$$

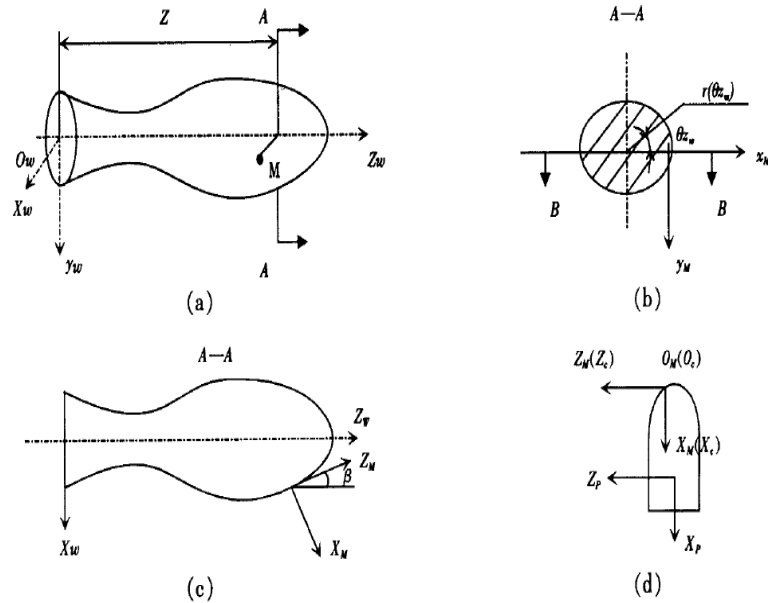

Figure 1. Work-piece coordinates describe figure coordinates describe Figure [12]

According to the stone tools Type for turning (shown in tool for blades) establish Tool cutting point C In the description matrix  $[{}^PT_C]$  for tools coordinate system  $O_P-X_PY_PZ_P$  And because the shown cutting point C and the Manufacturing Point M on workpieces coincide when the cutting.

$$[{}^PT_C] = \begin{bmatrix} 1 & 0 & 0 & x_0 \\ 0 & 1 & 0 & y_0 \\ 0 & 0 & 1 & z_0 \\ 0 & 0 & 0 & 1 \end{bmatrix} = [{}^PT_m] \tag{2}$$

In the numerical control processing process the cutting angle between the tool and the work should be to keep reasonable, meaning the right tool position posture can be given as:

$$[{}^WT_M] = [{}^WT_P] [{}^WT_C] \tag{3}$$

The matrix  $[{}^WT_P]$ describes the relative motion relationship between the cutting tool and workpiece, by above all available tools pose matrix can be give as:

$$[{}^WT_P] = [{}^WT_M] [{}^WT_C]^{-1} \tag{4}$$

$${}^wT_P = \begin{bmatrix} \cos\theta_{z_w} \cos\beta - \sin\theta_{z_w} \cos\theta_{z_w} \sin\beta & -x_0 \cos\theta_{z_w} \cos\beta + y_0 \sin\theta_{z_w} - z_0 \cos\theta_{z_w} \sin\beta + r \cos\theta_{z_w} \\ \sin\theta_{z_w} \cos\beta & \cos\theta_{z_w} \sin\beta & -x_0 \sin\theta_{z_w} \cos\beta - y_0 \cos\theta_{z_w} - z_0 \sin\theta_{z_w} \sin\beta + r \sin\theta_{z_w} \\ -\sin\beta & 0 & \cos\beta & x_0 \sin\beta - z_0 \cos\beta + z \\ 0 & 0 & 0 & 1 \end{bmatrix} \quad (5)$$

## 2) Turning motor function analysis

### (1) kinematical equation of tandem type formation

The movement of the machine function scheme is constituted with movement function units of generative generatrix and movement function units of wires. For a tandem structure of machine tools, the basic motion unit of the corresponding matrix  $[T_{WP}]$  combination that constitute the matrix of movement,

$$[T_{WP}] = M_1 M_2 \dots M_t \dots M_n \quad (6)$$

the cascade matrix of movement has been realized the pose matrix of cutting tools, so

$${}^wT_P = [T_{WP}] \quad (7)$$

$M_i$  Represents a matrix which has basic motor function in formula (6). There are six basic movement function in Descartes system of rectangular coordinates machine tool: the linear motion is X, Y, Z Three coordinates of the direction, and the rotational motion is X, Y, Z Three coordinates of the direction. where the matrices are:

$$X = \begin{bmatrix} 1 & 0 & 0 & x \\ 0 & 1 & 0 & 0 \\ 0 & 0 & 1 & 0 \\ 0 & 0 & 0 & 1 \end{bmatrix}, Y = \begin{bmatrix} 1 & 0 & 0 & 0 \\ 0 & 1 & 0 & y \\ 0 & 0 & 1 & 0 \\ 0 & 0 & 0 & 1 \end{bmatrix}, Z = \begin{bmatrix} 1 & 0 & 0 & 0 \\ 0 & 1 & 0 & 0 \\ 0 & 0 & 1 & z \\ 0 & 0 & 0 & 1 \end{bmatrix}, \quad (8)$$

$$A = \begin{bmatrix} 1 & 0 & 0 & 0 \\ 0 & \cos\alpha & -\sin\alpha & 0 \\ 0 & \sin\alpha & \cos\alpha & 0 \\ 0 & 0 & 0 & 1 \end{bmatrix}, B = \begin{bmatrix} \cos\beta & 0 & \sin\beta & 0 \\ 0 & 1 & 0 & 0 \\ -\sin\beta & 0 & \cos\beta & 0 \\ 0 & 0 & 0 & 1 \end{bmatrix}, C = \begin{bmatrix} \cos\gamma & -\sin\gamma & 0 & 0 \\ \sin\gamma & \cos\gamma & 0 & 0 \\ 0 & 0 & 1 & 0 \\ 0 & 0 & 0 & 1 \end{bmatrix}, \quad (9)$$

### (2) Movement analytical of the processing generatrix

When consider only generative Section type line of the non round special stone of non cylindrical surface, in formula (5) can make  $Z=0$ , And the cutting tool does not need to turn around the Y axis, if  $\beta=0$ , Getting the position attitude matrix when process generatrix.

$${}^wT_P = \begin{bmatrix} \cos\theta_{z_w} & -\sin\theta_{z_w} & 0 & -x_0 \cos\theta_{z_w} + y_0 \sin\theta_{z_w} + r \cos\theta_{z_w} \\ \sin\theta_{z_w} & \cos\theta_{z_w} & 0 & -x_0 \sin\theta_{z_w} - y_0 \cos\theta_{z_w} + r \sin\theta_{z_w} \\ 0 & 0 & 1 & -z_0 + z \\ 0 & 0 & 0 & 1 \end{bmatrix} \quad (10)$$

In order to get motor function scheme of processing generatrix through solving the last informula, According to its characteristics of position and posture set movement cascade matrix in advance, where the matrices are:

$$[T_{WP}]_{\text{母线}} = \begin{bmatrix} \cos\gamma & -\sin\gamma & 0 & a_1 \\ \sin\gamma & \cos\gamma & 0 & b_1 \\ 0 & 0 & 1 & 0 \\ 0 & 0 & 0 & 1 \end{bmatrix} \cdot \begin{bmatrix} 1 & 0 & 0 & x \\ 0 & 1 & 0 & b_2 \\ 0 & 0 & 1 & 0 \\ 0 & 0 & 0 & 1 \end{bmatrix} \cdot \begin{bmatrix} 1 & 0 & 0 & a_3 \\ 0 & 1 & 0 & y \\ 0 & 0 & 1 & 0 \\ 0 & 0 & 0 & 1 \end{bmatrix} \cdot \begin{bmatrix} 1 & 0 & 0 & a_4 \\ 0 & \cos\alpha & -\sin\alpha & b_4 \\ 0 & \sin\alpha & \cos\alpha & 0 \\ 0 & 0 & 0 & 1 \end{bmatrix} \quad (11)$$

$a_1, b_1, b_2, a_3, a_4, b_4$  in formula are literal which is translation coordinate transformation around in each movement between coordinate system.  $\gamma$  is the Rotary motion unit when around the workpiece symmetry axis  $Z_W$ ;  $\alpha$  is the Milling cutter head rotary cutting motion unit, which is belongs to the inside contact chain formation of the generatrix.

Because of  ${}^W T_P = [T_{WP}]$ , the  $\gamma = \theta z$ ,  $x = r - (\alpha + x_0)$ ,  $y = r - (b_2 + y_0)$  is the constant. In other words,  $\gamma, x, y$  is the function of  $r$  and  $\theta Z_W$ . Thus the rotary movement of the tool symmetry axis  $Z_W$  along the X axis and Y axis movement of the motor units must be in the processing generatrix. The exercise program is:

$$W/\gamma XY/T \quad (12)$$

(3) machine tool kinematic chain composition and motion axis configuration

Known by the formula (12), it can find a combination of engraving and milling motor function needs:

$$\{ W/\gamma XY/T, \dots, W/\beta XY/T \} \quad (13)$$

Analysis can be seen, to ensure that the tool turning any screw lead angle of the spiral column, the basic functions requirements of the turning movement: in addition to the independent X-axis, Y-axis feed, turning blade should be able to around the B axis rotary. Turning module of the basic motor function requirements are: four-axis three linkage.

### 3. Engraving and Milling Motor Function

Shaped stone carving milling of complex shapes, the machined surface is very complex and are often unable to use a unified mathematical model to describe. Therefore, in order to facilitate the study, assuming that the tool on the workpiece to move the curve on a parametric equation of the independent variable  $t$ , its coordinates can be expressed as:

$$\{X \ Y \ Z\} = \{x(t) \ y(t) \ z(t)\} \quad (14)$$

1) Stone carving milling tool and the workpiece positional relationship

According to the characteristics of engrave, processing any point M on the workpiece in the workpiece  $O_W-X_W Y_W Z_W$  coordinate system description matrix is

$$[{}^W T_m] = \begin{bmatrix} x'(t) & 0 & 0 & x(t) \\ 0 & y'(t) & 0 & y(t) \\ 0 & 0 & z'(t) & z(t) \\ 0 & 0 & 0 & 1 \end{bmatrix} \quad (15)$$

Stone carving and milling tool types to establish the point C of the cutting tool in the tool coordinate system  $O_P-X_P Y_P Z_P$  description matrix  $[{}^P T_C]$ .

At the same time as the cutting point C on the workpiece with processing points M coincide when they cutting, so

$${}^P T_C = \begin{bmatrix} 1 & 0 & 0 & x_0 \\ 0 & 1 & 0 & y_0 \\ 0 & 0 & 1 & z_0 \\ 0 & 0 & 0 & 1 \end{bmatrix} = {}^W T_m \quad (16)$$

$${}^W T_P = \begin{bmatrix} x'(t) & 0 & 0 & x(t) - x_0 x'(t) \\ 0 & y'(t) & 0 & y(t) - y_0 y'(t) \\ 0 & 0 & z'(t) & z(t) - z_0 z'(t) \\ 0 & 0 & 0 & 1 \end{bmatrix} \quad (17)$$

$x_0, y_0, z_0$  is the Coordinate of the cutting point C in the tool coordinate system, is a constant.  $x(t), y(t), z(t)$  is a variable, is a function on the event.

## 2) Processing generatrix and conductor movement parsing

To solve the movement function scheme of the processing generatrix through the equation 17, we can pre-establish the movement cascade matrix according to its position and pose of item, namely

$$[T_{WP}]_{\text{母线}} = \begin{bmatrix} \cos\gamma & -\sin\gamma & 0 & a_1 \\ \sin\gamma & \cos\gamma & 0 & b_1 \\ 0 & 0 & 1 & 0 \\ 0 & 0 & 0 & 1 \end{bmatrix} \begin{bmatrix} 1 & 0 & 0 & x \\ 0 & 1 & 0 & b_2 \\ 0 & 0 & 1 & 0 \\ 0 & 0 & 0 & 1 \end{bmatrix} \begin{bmatrix} 1 & 0 & 0 & a_3 \\ 0 & 1 & 0 & y \\ 0 & 0 & 1 & 0 \\ 0 & 0 & 0 & 1 \end{bmatrix} \begin{bmatrix} 1 & 0 & 0 & a_4 \\ 0 & \cos\alpha & -\sin\alpha & b_4 \\ 0 & \sin\alpha & \cos\alpha & 0 \\ 0 & 0 & 0 & 1 \end{bmatrix} \begin{bmatrix} \cos\beta & 0 & \sin\beta & 0 \\ 0 & 1 & 0 & b_5 \\ -\sin\beta & 0 & \cos\beta & c_5 \\ 0 & 0 & 0 & 1 \end{bmatrix} \quad (19)$$

In the equation,  $a_1, b_1, b_2, a_3, a_4, b_4, b_5, c_5$  are translations of coordinate transformation between each moving coordinate system which are constants.  $\gamma$  is rotary motion unit around the work piece symmetry axis of  $Z_w$ .  $\alpha, \beta$  are rotary cutting motion units of milling head which belong to the formation of the generatrix within the contact chain.

From the equation of  ${}^W T_P = [T_{WP}]$ , it can be resolved that  $\alpha, \beta, \gamma, x, y$  are functions of  $x(t), y(t), z(t)$  respectively. So the rotary motion unit  $\gamma$  along the symmetry axis  $Z_w$  of the work piece, the rotary motion units  $\alpha, \beta$  along  $X_w, Y_w$  of cutter and the shift along the X-axis, Y-axis are required motor units when processing the generatrix bar, and its exercise program is

$$W / \alpha\beta\gamma XY / T \quad (27)$$

## 3) The composition of machine tool kinematic chains and the configuration of moving axis

It can be known from equation (27) that the combination meets the need of engraving and milling motor function is:

$$\{W / \alpha\beta\gamma XY / T; \dots W / \beta\gamma XYZ / T\} \quad (28)$$

It can be seen from the analysis that to make sure the tool machine can cut the work pieces reasonably, the basic movement function requirements of special stone work pieces of solid of revolution and carved milling movement are, besides independent of the X-axis and Y-axis feeds, the carved with milling cutter should rotate and divide around B-axis and C-axis in the meantime the work piece can rotate around C-axis is required. This is the so called five axis linkage functions. To plane special stone work pieces, the basic movement function requirements of carved milling movement are, besides independent of the Z-axis, X-axis and Y-axis feeds, the carved with milling cutter should rotate and divide around B-axis and C-axis. Thus the basic requirement of the carved milling processing module is five axis linkage functions.

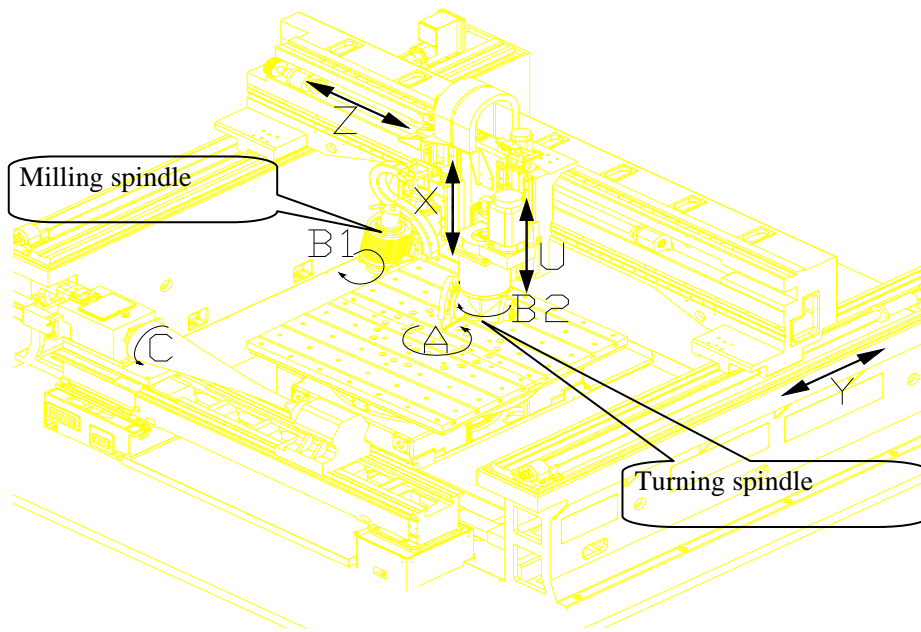

Figure 2. Virtual Prototype

**4. Modular Design of the Shaped Stone Milling Machining Center**

**1) Feed Shaft Configuration of Machining Centre**

According to the conclusion analyzed by generative of motor function, design turnery and milling machining centre of special stone as figure 2 shows. The processing center use the dynamic longmen structure, allocated with working head of turnery and saw cutting and double working heads of carved milling electric spindle, with eight servo drive unit, as figure 3 shows. Among them, the system composed by X-axis feed of carved milling slippery saddle, Z-axis feed of beam slippery saddle, Y-axis feed of beam and B1-axis rotation dividing of carved and milling working head, C-axis rotation dividing of horizontal type operating platform can realize five axis linkage NC machining of special axially symmetrical products; the system  $W / \alpha\beta XYZ / T$  which is composed of Carved by milling slippery saddle the X axis, beams to slip into the saddle z-axis feed, beams Y into giving vulture milling work head B1 axis rotation dividing, vertical table C axis rotation dividing can realize the five axis linkage nc machining of different stereo products

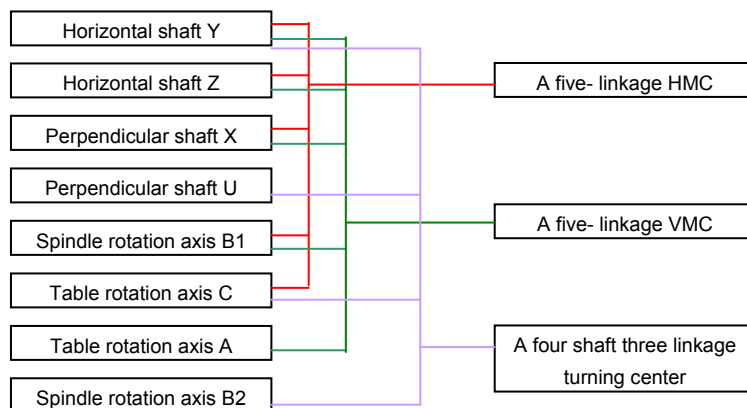

Figure 3. CNC feed axis configuration

The system  $W/\beta XZ/T$  which is composed of turning slippery saddle U shaft, beams slide into to saddle the Z axis into the stage of the C give horizontal axis rotation dividing, turning works head B2 axis rotation dividing can realize axially the four shaft three linkage NC machining of symmetrical products

## 2) Machining Centers Modular Configurations

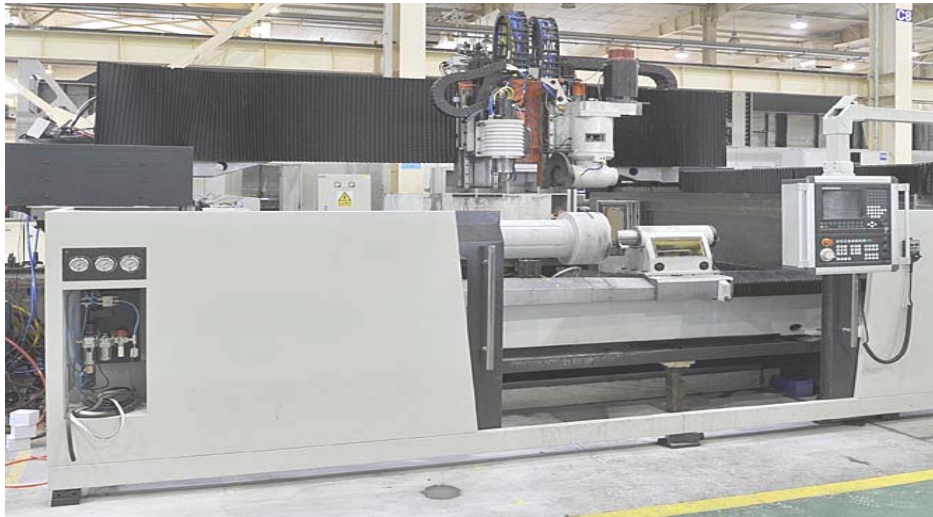

Figure 4. Actual prototype

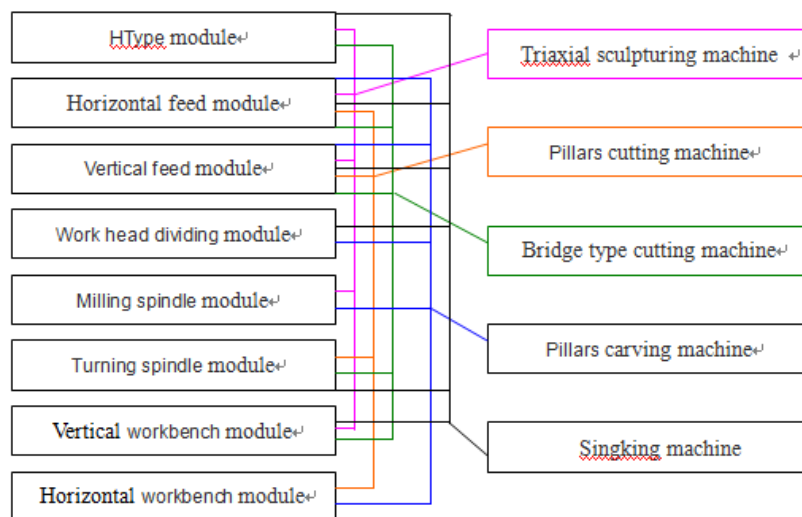

Figure 5. CNC modular configuration

According to the movement function of Generative, special stone material processing center equipped moving axis functional configuration is shown in figure 4.

The processing center uses dynamic longmen structure that the system uses longmen pillar to the module, beams slide into saddle into to module, vertical axis into to module, work head dividing module, engraving and milling electric spindle, turning the work

module, vertical and horizontal head workbench module and so on, and uses a certain type of multi-axis nc system, which has insert structure and the block structure system.

As shown in figure 5, the numerical control system and hardware module configuration can be assembled into the 3 d plane stone carving machine, cutting machine, the bridge type cutting machine, the stone carving machine, three-dimensional sculpture machine and so on the different models for the customized production.

## 5. Conclusion

Special stone axes of turning processing machine tool for configuration:  $W/\gamma XY/T$  should have four shaft three linkage movement function. pecial stone carving of milling process machine for axes configuration:  $\{W/\alpha\beta\gamma XY/T; \dots W/\beta\gamma XYZ/T\}$  should have five axis linkage function. Modular structure design and block the numerical control system realize milling machining center of stone car customized production ability, obtaining good market benefit.

## References

- [1] Wu TK, Huang SC, & Meng YR. Evaluation of ANN and SVM classifiers as predictors to the diagnosis of students with learning disabilities. *Expert Systems with Applications*. 2008; 34: 1846–1856.
- [2] Wu CH, Tzeng GH, & Lin RH. A novel hybrid genetic algorithm for kernel function and parameter optimization in support vector regression. *Expert Systems with Applications*. 2009; 36: 4725–4735.
- [3] Xian GM. Mechanical failure classification for spherical roller bearing of hydraulic injection molding machine using DWT–SVM. *Expert Systems with Applications*. 2010; 37: 6742–6747.
- [4] Xiao J, Xu J, Chen Z, Zhang K, & Pan L. A hybrid quantum chaotic swarm evolutionary algorithm for DNA encoding. *Computers & Mathematics with Applications*. 2009; 57: 1949–1958.
- [5] Wang, Dinglei, Li, Jianyong, Xu, Wensheng The methods of factor weight's determine in the process of cluster. *TELKOMNIKA Indonesian Journal of Electrical Engineering*. 2012; 10(5): 1137-1141.
- [6] Reuven Katz, Yoram Koren. Reconfigurable Machines. *ESDA*. 2008; 59(56): 145-152.
- [7] Zhao, Min, Jiang, Zhiqiang, Jia, Longjuan, Guo, Yuxiang Experimental research on wear of electroplated diamond mill in cutting stone. *Shenyang Jianzhu Daxue Xuebao (Ziran Kexue Ban)/Journal of Shenyang Jianzhu University (Natural Science)*. 2008; 24(5): 868-871.
- [8] Zhang, Ke, Wu, Yu-Hou, Xu, Xiang-Hui, Zheng, Chao-Fang, Wei, Yong-Tao Online measurement of roundness errors of parts based on PMAC, *Shenyang Jianzhu Daxue Xuebao (Ziran Kexue Ban)/Journal of Shenyang Jianzhu University (Natural Science)*, 2005; 21(5): 597-600.
- [9] Ke Zhang, Dehong Zhao, Yuhou Wu. The Detection and Analysis of Straightness Errors on Pillar and Guide Rail of Alien Stone Turning-milling Compound Machining Center. *Applied Mechanics and Materials*, 2011, 9(8): 80-81.
- [10] Lu Feng, Dehong Zhao, Yuhou Wu. Modal Analysis of Special-shaped Stone Multi-function NC Machining Menter. *International Journal of Digital Content Technology and its Applications*. 2011, 5(8): 168-174.
- [11] Yanhui, Gao, Qianguai, Xiao, Shousong, Hu, Xiao, Ju Flight control system simulation platform for UAV based on integrating simulink with stateflow. *TELKOMNIKA Indonesian Journal of Electrical Engineering*. 2012; 10(5): 985-991.
- [12] He, Tao Safety analysis and design for the switch control unit of all-electronic computer interlocking system. *TELKOMNIKA Indonesian Journal of Electrical Engineering*. 2012; 10(5): 1057-1061.