

Sequence Phase Analysis of Phased Rectifier

Chen Zhong-Xiao*, Li Yan-Fang, Zhang Li-Guang, Chen Xing-Yu

Xi'an Technological University

Weiyang Campas of Xi'an Technological University Shaanxi Province

*Corresponding author, e-mail: lyf_xiang@163.com

Abstract

At present, three-phase bridge type full controlled is the most widely applied in all kinds of rectifier circuit. To guarantee the normal work of the phase control circuit, it is the most important thing that should be according to the size of the triggering angle at the right moment to the thyristor trigger of the circuit on effective puls. Nature commutation point is the earliest time of the thyristor trigger conduction, it is the starting point of thyristor trigger calculation angle, if want to change the size of the thyristor can only be based on this increase. It is difficult that to find a natural commutation point of the rectifier circuit. Find nature commutation point can be analyzed corresponding thyristor turn-on. But generally find natural commutation point will be lag behind, lead to trigger angle lags behind, according to this problem can make anyone phase voltage delay after zero, so natural commutation point can make the output voltage to achieve maximum. In fact, the above process is to realize sequence analysis and sequence adaptive.

Key words: Bridge type all control the rectifier, Nature commutation point, Sequence phase analysis

Copyright © 2013 Universitas Ahmad Dahlan. All rights reserved.

1. Introduction

Phase shifting trigger circuit is core part of three-phase thyristor circuit. The thyristor controlled rectifying circuit is through control the size of the triggering angle α , that is to say control the starting phase of trigger pulse to control the size of the output voltage, belong to phase control circuit. The old methods can only to solve the sequence adaptive and synchronous signals and phase of main circuit still need to artificial debugging, so a new method has been developed. In the premise of getting synchronous signal, automatic recognition the phase sequence phase rectifier bridge [1], namely phase sequence phase adaptive rectifier has a practical significance. This paper by using synchronous signal produce circuit of special design and inner link of power grid different voltage levels and the relationship of load current and the voltage, solve the problem of phase sequence phase automatic identification [2-3].

2. The Composition and Working Characteristics of Circuit

The principle diagram of three-phase bridge type full controlled rectifier circuit is shown in figure1. It is a group of total anode thyristor (VT4, VT6, VT2) and a group of the cathode thyristor (VT1, VT3, VT5) combination of the series [4-5].

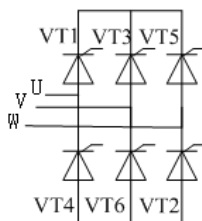

Figure 1. Three-phase bridge thyristor trigger pulse sequence relationship

Six pulse relationship of three-phase full bridge thyristor trigger circuit is as shown in figure 2. When the AC input according to U, V, W phase sequence is arranged, Six thyristor conducted in turn VT1 VT2 VT3 VT4 VT5 VT6, phase difference in turn 60° . One of the U+ and so on representatives to U phase the positive half cycle as the pulse of synchronous signal (namely and U connection bridge legs above the thyristor trigger pulse), U- representatives to U phase in the negative half cycle as the pulse of synchronizing signal. The combination of double pulse for diagram is the adjacent two pulse, such as the combination of U + and W- is the trigger pulse of thyristor in which U connection on the arms of the bridge.

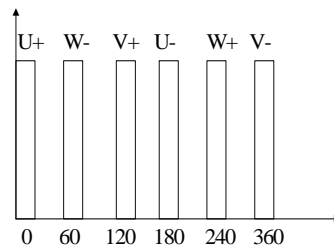

Figure 2. Three-phase bridge thyristor trigger pulse sequence relationship

The design of digital trigger circuit of system structure as shown in figure 3. Control voltage through a voltage to frequency conversion obtained pulse as the count pulse (higher voltage pulse frequency gets higher), in CPLD use fixed number counter to its count to control the trigger pulse phase angle, the higher the pulse frequency counter counts the shorter the time, phase angle is smaller, so by controlling the voltage variation to realize pulse phase shift, phase angle in the range of about 0 to 150 degrees. In Figure 3, the external clock is used to control the pulse width.

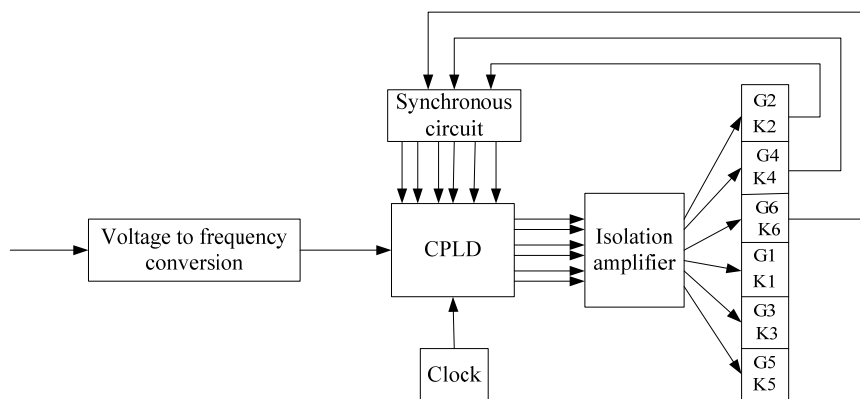

Figure 3. Digital phase control trigger circuit

3. Adaptive Function Realization

Adaptive function realization in order to get trigger pulse phase angle, which determine the trigger pulse relative to the input voltage position, must from the three-phase AC power supply into the synchronous signal [6]. The traditional approach is from the supply side through the three transformers have the phase synchronization signal, thus increasing the cost of the system, and the installation is not convenient. You can see from Figure 4 that the VT4, VT6 and VT2 of the K thyristor is connected to AC power supply end, therefore can from the digital trigger six way pulse output terminal with VT2, VT4 and VT6 three K very connected to the three terminal into voltage signal as synchronous signal (Figure 5), the use of optocoupler voltage

isolation, so there is no need for synchronous transformer, not only can save the cost, but also can realize the adaptive function.

The principle of synchronization circuit is shown in figure 3. Here in one phase as an example. In 1, 2 and 1 circuit, at the same time filtering, can prevent the power grid voltage notch effects synchronous signal [7]. Although filtering circuit the voltage signal delay angle, but after a delay of two signals received from the optical coupler two input ends, then it becomes the two voltage signals are subtracted, equivalent to a phase line voltage [8], so that the optical output signal phase and advanced by 30 DEG, so the six output voltage signal and the phase of the voltage of power grid phase difference = 30 degrees, can be adjusted by 1, 2 and 1 Parameters to change, usually take about 30 °.

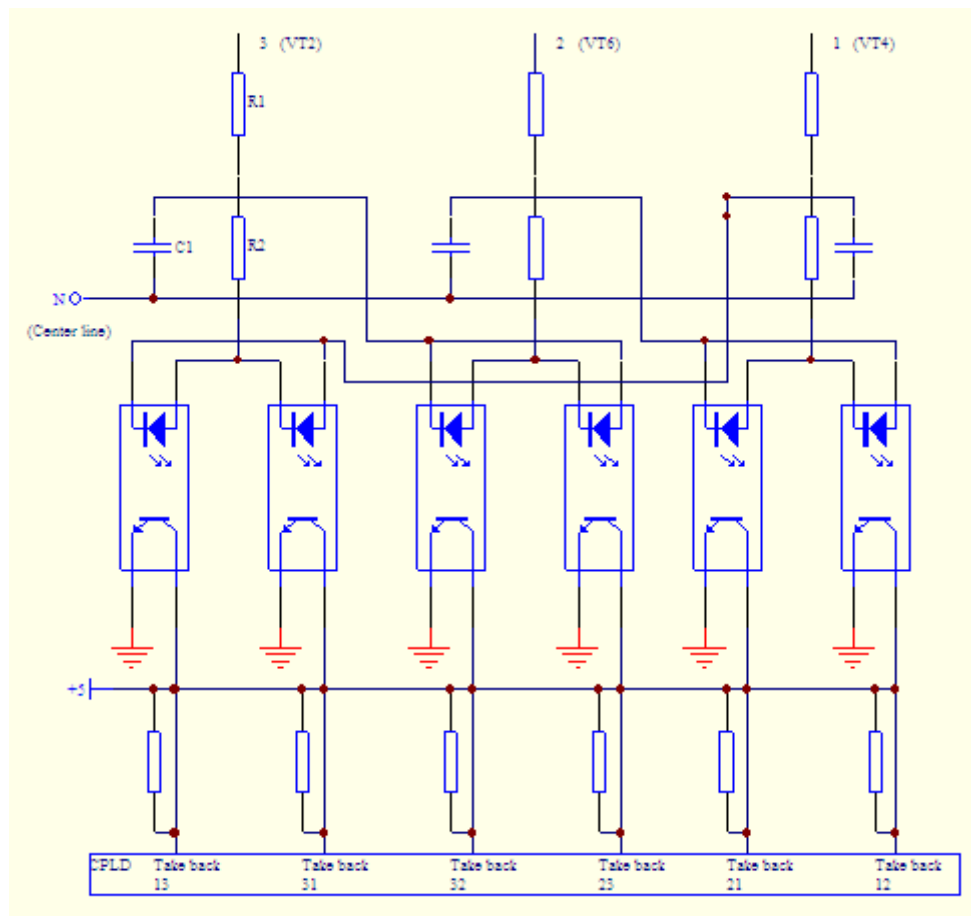

Figure 4. Schematic diagram of synchronous circuit

Because the optical input unidirectional, such that each optical output signals as the input voltage of the positive half cycle of the square wave signal is formed, which has three road respectively corresponding to U, V, W three-phase voltage positive half cycle phase, the other three corresponding to the negative half cycle phase. Six ways synchronization signal after entering CPLD [9], the six synchronization signal generating pulses are combined, as each trigger pulse synchronization signal. Each thyristor drive pulse synchronization signal as shown in Figure 4.

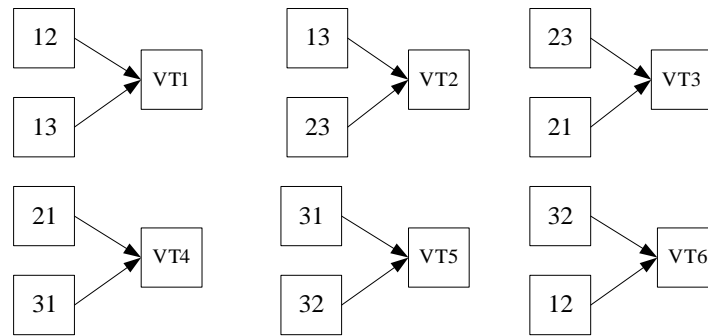

Figure 5. Pulse distribution relationship

4. The Produce Circuit of Synchronous Signal

Natural commutation point is located in every line voltage 60° moment .When positive sequence, 6 line voltage commutation order is $U_{AB}, U_{AC}, U_{BC}, U_{BA}, U_{CA}, U_{CB}$; When negative sequence, the phase sequence order is just the opposite.

As shown in figure 6 the 24 kinds of phase relationship of synchronous signals and main circuit voltage, the odd position is not located in 60° phase of any line voltage, not effective synchronous signal; even the position is effective synchronized signal, but prior is unknown. Therefore, Design the produce circuit of two way synchronous signals [10-11]. But the source can be taken from the any way 220 V power supply. As the chart 7 shows, through amplitude limit of going directly into the comparator after 1 and output INT1, another pass after phase shifting into comparator after 2 and output INT2 [12] .

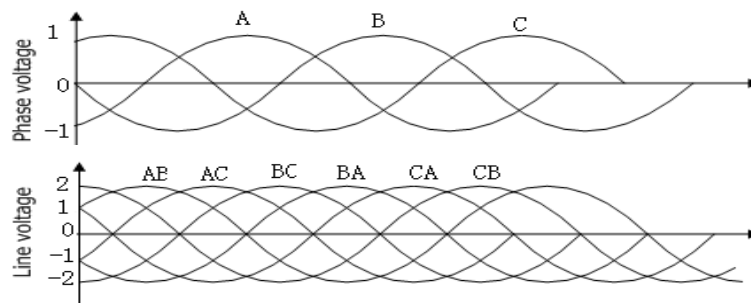

Figure 6. Synchronized signal and main circuit three-phase voltage of the relationship

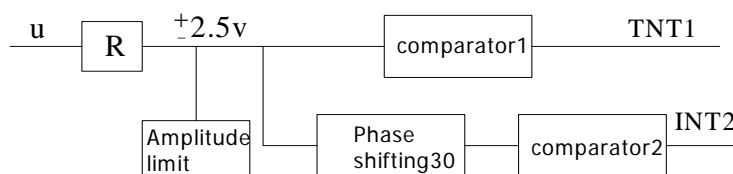

Figure 7. Synchronous signal circuit

5. Phase Phase Sequence Prediction

As graph7 produce a certain way synchronous signal after zero is interrupt source. When in the interrupt processing trigger a pair of bridge arm, there are six kinds of choice that is VT1, VT3, VT4, VT2, VT5, VT6. Reference figure 6, at any place of 24 position, only have three

voltage under positive can trigger thyristor turn-on. When use and the synchronous signal phase difference 30 from the other way synchronous signal, also have the same result[13].

Assume that figure 7 formation of two ways synchronous signal passing zero located in figure 4 position 1 and 2 position. In the position 1, trigger T61, T56, T45 respectively make the line voltage U_{AB}, U_{CB}, U_{CA} conduction; In the position 2, trigger T56, T61, T12 respectively make the line voltage U_{CB}, U_{AB}, U_{AC} conduction. After conducting current starting from scratch growth, because only one trigger, line voltage natural zero passage after become negative[14], Due to the load resistance consumption make current reach maximum began to decay and finally at turn-on the bridge arm recovery shut off. If initial phase is smaller of the line voltage of conduction, the conduction time is more longer. According to the conduction time from small to large order, in turn is $U_{CA}(1)U_{CB}(2)U_{CB}(1)U_{AB}(2)U_{AB}(1)U_{AC}(2)$, in the brackets of the numbers are represent position 1 or 2 position. From relationship of the trigger point and the phase of voltage see, Corresponding to the above line voltage phase for $150^\circ, 120^\circ, 90^\circ, 60^\circ, 30^\circ, 0^\circ$. Load impedance may affect every time of conduction, but does not influence to sort results.

We can draw the conclusion: it is the trigger that at online voltage 0° and 60° phase are caused by the same way synchronous signal and it is located in the sort of even position. Make the line voltage 60° in the phase of conduction synchronized signal is zero line voltage is natural commutation point; If in the conduction of phase line voltage 0° (conduction time the longest) corresponding bridge arm Numbers of relative phase 60° conduction line voltage of the corresponding bridge is the increasing arm Numbers, That is the main loop positive sequence, or for a negative sequence[15].

Define a set of array $PU=[T_{61}, T_{12}, T_{23}, T_{34}, T_{45}, T_{56}]$, make j represents an array subscript, when $j = 0$ says trigger T6 and T1, that is in turn on.

Can one by one to test and verify, when the two road alignment signal is located in figure 2 any adjacent position the above conclusions are established. The corresponding synchronized signal of even position is effective synchronized signal, INTNUM. Will the fourth line voltage corresponding bridge arm of PU subscript deposited in the corresponding Numbers variable \dot{J}_1 ; Will a line voltage of the corresponding 6 arm Numbers corresponding bridge PU subscript deposited in a variable \dot{J}_2 . If $\dot{J}_1 < \dot{J}_2$ (or when $\dot{J}_1 = 5, \dot{J}_2 = 0$), indicating that the main loop is positive sequence, remember variables; If $\dot{J}_1 > \dot{J}_2$ (or when $\dot{J}_1 = 0, \dot{J}_2 = 5$), indicating that the main loop is negative sequence[16].

According to the above analysis design a automatic identification algorithm sequence phase. The algorithm output three parameters; effective synchronous signal, that \dot{J}_1 stands for the PU subscript when every time synchronization signal zero interrupt should trigger, said sequence. In the digital phased rectifier applications, it is always to load current sampling, so the algorithm does not increase device cost, but also because of remove synchronous transformer to reduce the cost of the equipment.

6. Reconstruction Phase Controlled Rectifier

6.1. Traditional Phased Rectifier Realization Principle

Says from the figure 7 synchronous generated signal is the external synchronizing signal. It is hand by the external interrupt of micro controller (MCU). The within synchronous signal is that the synchronous signal 6 times frequency and form another 5 road alignment signal, by one of the timepiece's interrupt of MCU is realized. When start time after the In synchronous signal, long time by phase-shifting α angle is decision. When the timing time is enough, we will to choose the right PU array subscript, according to above send out a suitable signal of thyristor trigger, this task can be realization by another timepiece's interrupt of MCU,

called trigger interrupt. Phase Angle α and long time move by the software main circulation part calculation.

6.2. To Improvement of the Traditional Phased Rectifier's Algorithm

Define variable is A, when $\alpha < 60^\circ$, A = 0; when $60^\circ < \alpha \leq 120^\circ$, A = 1. Using the phase sequence automatic identification algorithm improved phase phased rectifier, it is main to improve the trigger interrupt. According to the ahead of variables definition, the original trigger in PU subscript interrupt formulas is the $(j + 6 - A) \% 6$. The improved algorithm related relevant with sequence, when is positive sequence, the formula is $(+ j + 6 - A) \% 6$; When is negative sequence, the formula is $(j + 6 + A) \% 6$.

7. Conclusion

In order to solve the phased rectifier installation debugging match sequence phase of tedious process, put forward a kind of sequence phase adaptive method. The method includes three parts: a synchronous signal circuit of special design, signal and the main loop synchronous three-phase voltage sequence phase relationship of the calculation method and include a sequence phase adaptive function of the rectification algorithm. This method does not increase any cost, because removed the synchronous transformer not only reduce equipment cost, but also applicable to any load.

References

- [1] Liu Ziken, Zhang Changyong, Zhang Fumin. A new type of phase locked loop digital trigger system. *Journal of Hebei University of Technology*. 2003: 4.
- [2] Wang Qinghua Without synchronous transformer phase self-adjustable thyristor trigger circuit. *Power electronic technology*. 1998: 4.
- [3] Du Haijiang, Shi Xinchun. Phase sequence phase adaptive analysis and Realization of phase-controlled rectifier with. *Journal of Electrician Technique*. 2005: 2.
- [4] Risnidar Chan, I Daut, Syafruddin H, Yusniati Yusniati. Relationships between Harmonic Characteristics and Different Types of Voltage Source. *TELKOMNIKA Indonesian Journal of Electrical Engineering*. 2012: 10(2): 219-228.
- [5] Shahrin Md Ayob, Zaenal Salam, Abdul Halim M Yatim. Non-Sinusoidal PWM Method for Cascaded Multilevel Inverter. *TELKOMNIKA Indonesian Journal of Electrical Engineering*. 2012; 10(4): 670-679.
- [6] CHEN Zhongxiao, LI Yanfang Hardware Design of Induction Heating Power Inverter Controller. *Journal of SHANXI electric power. Application*. 2012; 14(8): 34-37
- [7] R Moffat, PC Sen. "Digital phase_locked loop for Induction motors Peed control". *IEEE Trans-1nd, Application*. 1998; 34(3).
- [8] Chen Zhong-xiao, Li Yan-fang. Three-Phase Bridge Type All Control of Rectifying Sequence Phase Automatic Identification. *Engineering and Technology (S-CET)*. 2012 Spring Congress on
- [9] Kim C. Member, Senior Member, IEEE. "A Neuro_Fuzzy Controller for Mobile Robot Navigation and Multirobot Convoying". *IEEE Transactions on Systems, Man, And Cybernetics-Part B: Cybernetics*. 1998; 28(6).
- [10] A Unity Power Factor Three Phase PWM SCR Rectifier for High Power. *IEEE transactions on Industry Applications*. 2002: 38.
- [11] Wang Zhaoan, Huang Jun. Power electronic technology. *Beijing: Mechanical Industry Press*. 2000.
- [12] Donald A Neamen. *Electroaie Circut Analysisand Design (Second Edition)*. Tsinghua University press, 2000.
- [13] Jinlong, Wang Zhihe. Digital trigger circuit based on CPLD model. *Power electronics technology*. 2001.
- [14] JAI PA. *Power Electronic Systems Theory and Design*. Beijing: Tsinghua University Press, Prentice-hall. 2001.
- [15] Jiang Huihui, Shen JinFei. New series resonant inverter control strategy phase shifting. *Computer simulation*. 2008.
- [16] Zhang Cengke. The fuzzy mathematics in the application of automation technology. Tsinghua University press. 1997.