

Development of a stand-alone and scalable weather monitoring system using two-way VHF radios

Maria Lynn B. Carbonell, John Michael R. Carpio, Juan Carlo C. Medina, John Paul Perote,
Tristian Jhan J. Tamayo, Gerino P. Mappatao

Department of Electronics and Communications Engineering, De La Salle University, Philippines

Article Info

Article history:

Received Feb 8, 2020

Revised Apr 7, 2020

Accepted Apr 21, 2020

Keywords:

Scalable

Sensor

Two-way radio

VHF radio

Weather monitoring

ABSTRACT

As weather-related disasters visit the Philippines regularly and the intensity increases over time, an all-weather system of monitoring the weather and its effects is necessary. Specifically, when super typhoon Yolanda (with international name Haiyan) devastated central Philippines in 2013, almost all public terrestrial communication systems were down. This paper proposes a “back-to-the-basics”, stand-alone and scalable system used to monitor the weather in several locations. The system is not dependent on the public telecommunication systems but rather uses the old but reliable Very High Frequency (VHF) two-way communication system for the transmission of sensor data such as temperature, wind speed and direction, rainwater precipitation and water level. The scalability feature of the system allows the addition of more monitoring stations to cover a wider area. Based on the tests conducted with the prototype composed of a command center and three (3) local monitoring stations, the system was able to demonstrate the transmission of weather data as well as the scalability feature of the system. The system is envisaged that the proposed system can be very useful in weather monitoring in a provincial setting where the command center is in the provincial capitol and the monitoring stations are in municipalities and cities within the province.

Copyright © 2020 Institute of Advanced Engineering and Science.
All rights reserved.

Corresponding Author:

Gerino Mappatao,

Department of Electronics and Communications Engineering,

De La Salle University,

2401 Taft Avenue, Malate, Manila, Philippines.

Email: gerino.mappatao@dlsu.edu.ph

1. INTRODUCTION

Located along the typhoon belt in the Pacific, the Philippines is visited, on the average, by 20 typhoons each year [1]. Many typhoons come with strong winds and excessive rainfall resulting to flooding, loss of lives as well as damages to infrastructure and agriculture. Worst, after or even during the landfall of a strong typhoon, public telecommunication services are intermittent, or not available at all. During extreme weather conditions, there is a need for a system that is robust, reliable, low on cost and maintenance, and can cover a wide area to continuously monitor weather data.

In this regard, several systems were deployed and developed to monitor the weather. In 2011, PAGASA, the weather bureau of the Philippines, started deploying several Automated Weather Stations (AWS) in various locations in the country [2]. An AWS monitors weather-related data and transmits the same to PAGASA head office in Quezon City on real-time basis. It uses the Short Message Service (SMS) of telephone companies which is prone to signal outage during extreme weather conditions. It can also be fitted with satellite transmitters if the SMS capability fails [2]. However, the acquisition of satellite communication equipment is costly and the subscription is expensive.

Monitoring systems were also developed and published as undergraduate theses [3, 4]. One of these systems uses a CMU (Control Monitoring Unit) and several RPTs (Remote Process Transceivers) stationed in predetermined locations. For the transmission of data, it uses transceivers that operate in the 900 MHz ISM (Industrial, Scientific and Medical) ultra-high frequency (UHF) radio band. The transmitter part of the transceiver has a maximum power of one (1) watt. However, one drawback of the system is the high attenuation at the 900 MHz band limiting the link range and reliability. Further, the transceiver itself is not commonly available and has fragility issues.

This paper presents a system that is a good alternative to the AWS and the systems described in [3, 4]. The proposed system is more reliable since it operates at a lower frequency and entails a lower cost to construct. A provincial local government in Philippine setting can easily implement it. If the power source and electronic components of the proposed system are properly secured, the reliability of the system depends solely on the robustness of the antenna installation. The system uses a network of two-way radio transceivers operating in the Very High Frequency (VHF) band, specifically at 144 MHz (Transmit) and 136 MHz (Receive) with a 5.5-watt maximum transmitter power. Since the system operates at VHF, propagation loss is much lower. Signal attenuation is more predictable at VHF compared to UHF, especially during the occurrence of heavy rains and cloud formations. Further, the transceivers used in the proposed system are the more common and reliable two-way communication transceivers locally available. These transceivers are used by almost all local government units in the Philippines. Unlike the AWS, the proposed system is a stand-alone system, neither relying on cellular telephone systems that are prone to power outages during severe typhoons nor the more expensive satellite systems. Also, the proposed system has scalability feature that allows the range to be extended using additional nodes. It allows more monitoring stations to be added to increase the area being monitored. This feature is made possible through a user-defined protocol (UDP) [5]. The proposed system is ideal in remote and mountainous areas where unreliable cellular signal is common.

2. METHODOLOGY

The proposed system is composed of a command center (CC) and several remote monitoring stations (RMS) as illustrated in Figure 1(a). It is developed to gather sensor data from the RMSs then transmit and eventually received, displayed and stored in the CC. It is necessary that the first remote monitoring station (RMS1) is nearer to the CC compared to RMS2 and RMS2 is nearer than RMS3 from the CC, and so on. In an ideal setup, the CC is located in the provincial capitol (the office of the provincial governor) while the RMSs are located in cities or municipalities in the province, preferably places that are flood-prone. In the system setup illustrated in Figure 1(a), the CC communicates with RMS1, RMS1 communicates with RMS2, RMS2 with RMS3 and so on. The CC is not allowed to communicate directly to RMS2 or any RMS other than RMS1. The request for data gathering emanates periodically from the CC to the RMSs. Each RMS (except the last RMS) acts as a relay station for the succeeding RMSs to receive the same request from the CC. Referring to Figure 1(a), the request from CC will be received by RMS1, sends its sensor data to CC where the same data will be displayed and eventually stored. After the reception of the sensor data of RMS1, the CC will send a request message intended for RMS2 via RMS1. RMS1 must determine that the received request is intended for RMS2 and not for it and so it passes to RMS2. Upon reception of the request, RMS2 sends its sensor data to RMS1, RMS1 then relays the same data to CC where the sensor data of RMS2 will be displayed and stored. After RMS2 transmitted its data and eventually received and stored in the CC, the CC again sends a request for the transmission of sensor data, this time, for RMS3. The request message will be received by RMS3 through RMS1 and RMS2. When RMS3 receives the request from RMS2, it gathers its sensor data and transmits the same to the CC through RMS2 and RMS1. The sensor data of RMS3 will then be displayed and stored in the CC. The process goes on until the last station is done receiving the command and transmitting its data. If, in any case, the request from the CC is received directly by RMSs other than RMS1, the request is simply ignored by these RMSs. Also, if an RMS transmits its data, all RMSs farther than the transmitting RMS will ignore the transmission and do not relay the same. This is implemented through the fields in the UDP. The sending of requests for sensor data by the CC can be set to an hourly basis or on demand by pressing a button in the CC.

Two-way radio transceivers operating in the VHF band are used both at the CC and at all RMSs for the transmission and reception of sensor data and data requests from the CC. Each RMS gathers data on air temperature, wind speed and direction, amount of rainfall and water level through several sensors. The design of the system was made after a thorough review of existing theorems and similar systems [6-8] and a more detailed block diagram of the system was developed and is shown in Figure 1(b). The CC consists of a transceiver, a Dual-Tone, Multi-frequency (DTMF) converter, a microcontroller and a computer where the Graphical User Interface (GUI) resides. All RMSs have a VHF transceiver and a set of sensors. A microcontroller and a DTMF converter similar to the one described in the CC is also used in each RMS. Each of these parts of the system are then described for the reader to understand the design and development of the whole system.

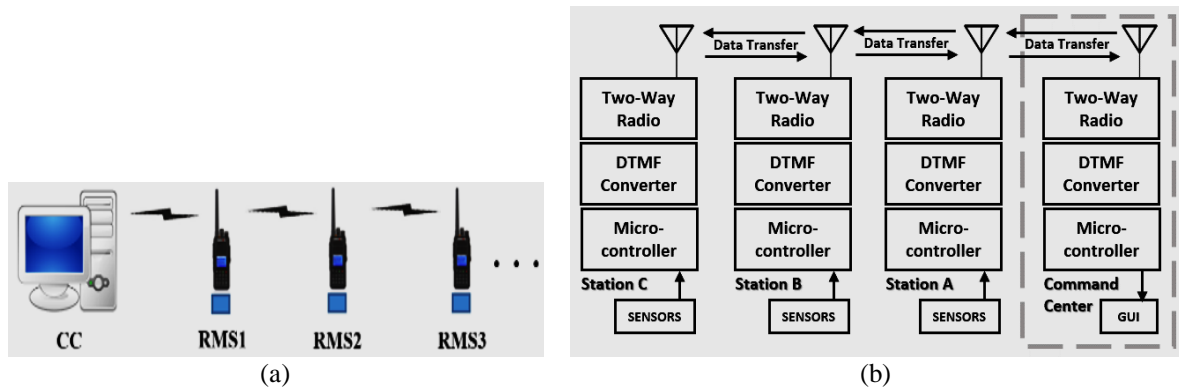

Figure 1. (a) The setup of the weather monitoring system, (b) general block diagram of the weather proposed system

2.1. The command center (CC)

The CC has a computer where the current sensor data from the RMSs are displayed and stored. It also has a microcontroller that controls the sending of request for sensor data periodically, among other functions. A DTMF converter interfaces the microcontroller input/output (I/O) and the transceiver I/O. Specifically, the DTMF converter transforms the electrical digital I/O from the microcontroller to acoustical quantity that the transceiver can accept. It also transforms from acoustical to electrical quantity. The microcontroller is used to control the collection and conditioning of data from the sensors and the transmit/receive function of the transceiver. Figure 2(a) shows the flow diagram of the CC. It illustrates the overall operation of the CC to implement its functions, both for the automatic periodic transmission of request message and for manual operation. For manual operation when sensor data are needed from a particular RMS, a specific push-button is pressed.

The CC uses a UDP when it requests for sensor data. The UDP used in the CC is composed of 12 bits and the structure is shown in Figure 2(b). The UDP is also designed to make the scalability of the project possible. The protocol in sending a request is composed of the following 4-bit fields: origin, next, destination. The origin field determines the identification of the source of the data, whether it be coming from a remote station or from the CC. In the prototype of the system, the CC, RMS1, RMS2 and RMS3 are given the following identification: 0, 1, 2, and 3, respectively using four bits each. The next field determines the next station that should receive the current data transmission. The destination field determines the target/final station the data is destined to. The number of bits in each field in the UDP addresses the scalability feature of the system. When the number of bits assigned to identify an RMS is increased, more RMSs can be accommodated. In the flowchart, the system takes 2 seconds to receive sensor data from an RMS from the time a request was made. Sensor data that were transmitted come only from a particular RMS at any particular time. Since each RMS transmits one set of data at a time, the amount of data that were transmitted per unit time remains the same irrespective on the number of RMSs. This follows that the bandwidth of the data also remains the same. The maximum number of RMSs that the system can take is determined by the minimum period that sensor data should be transmitted regularly. If sensor data should be sent to the CC on an hourly basis, the maximum number of RMS would be 1800 (3600 seconds/2 seconds each station). A system with 1800 nodes is such a big system. If the proposed system is deployed in a province in the Philippines, a system with 50 nodes would be more than enough.

Visual Basic program is used in the implementation of the GUI to display the values collected from the sensors of all the stations. The output of the microcontroller at the CC is connected to the COM1 port of the computer. Since Visual Basic is an event-driven programming language, a program is designed to check for data sent through the COM1 port every two milliseconds. If there are available data, the same are read and then displayed as current sensor data. These data will eventually be saved in a database after the reception of another set of new sensor data. Previous data are saved in Excel files. The stored sensor data also contains the date and the time of reception.

The two-way radio transceiver used in the implementation of the prototype both in the CC and in each of the RMSs is the ICOM IC-V80 VHF transceiver and is shown in Figure 2(c). It is a handheld type transceiver operating over the frequency range of 144 to 148 MHz in transmit mode and 136 to 174 MHz in receive mode. Its transmit power can be set to three ratings: 5.5watts, 2.5 watts and 0.5 watt. This two-way radio can last up to a maximum of 19 hours operating time with the supplied 2000 mAh Li-Ion battery. It also has an IP54 rating assuring that the transceiver is water resistant and has protection against dust and dirt [9].

The DTMF converter diagram is shown in Figure 2(d). It is basically composed of an encoder and a decoder to fulfill its transducer functions. Specifically, it uses the W91312 Tone Generator and the CM8870

Integrated DTMF. Between the radio transceiver and the DTMF module is an auxiliary headset to avoid messing with the internal circuitry of the radio. The generated DTMF will go through the microphone terminal of the headset, and the received DTMF signal will pass through the earphone terminal. The microphone part is electrically isolated from the circuit via a transformer to ensure that only AC signals will go through the microphone. An amplifier circuit is implemented at the output of the W91312 DTMF encoder and just before the microphone terminal to ensure sufficient signal level is fed through the microphone. The Push-to-Talk function of the radio is turned-on using an electromechanical relay. It will activate only when the node (RMS) is ready to transmit and deactivated when the node is done transmitting. An LED indicator is placed at the relay to indicate that the transceiver is in the transmit mode.

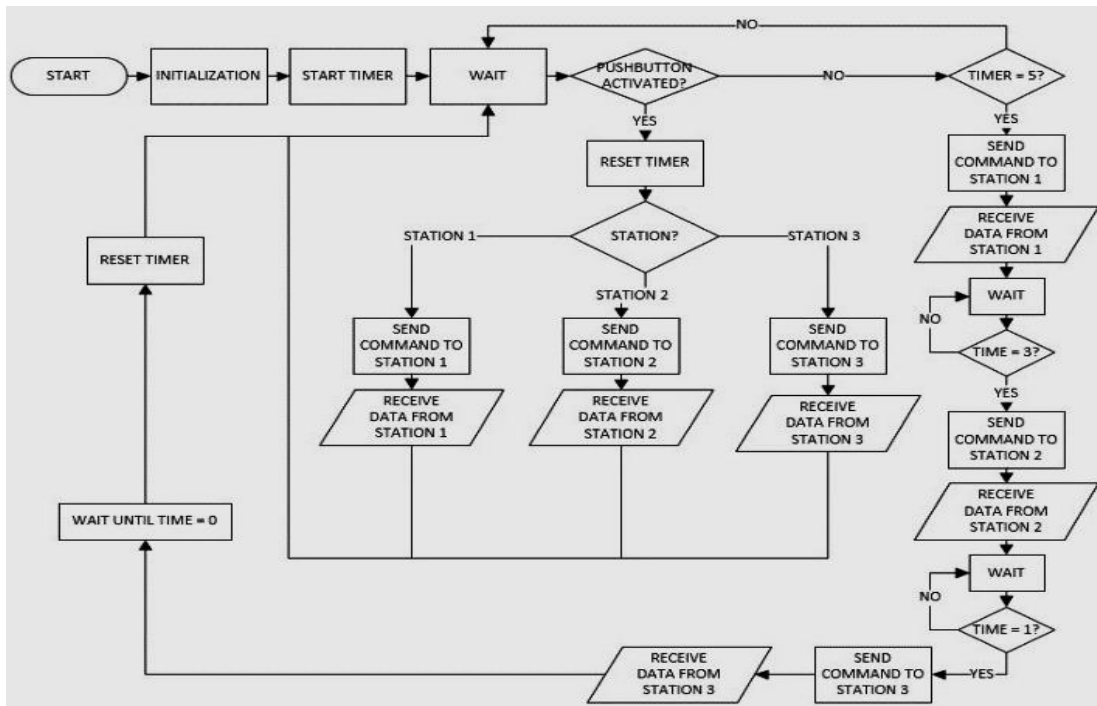

(a)

Origin	Next	Destination
4 bits	4 bits	4 bits

(b)



(c)

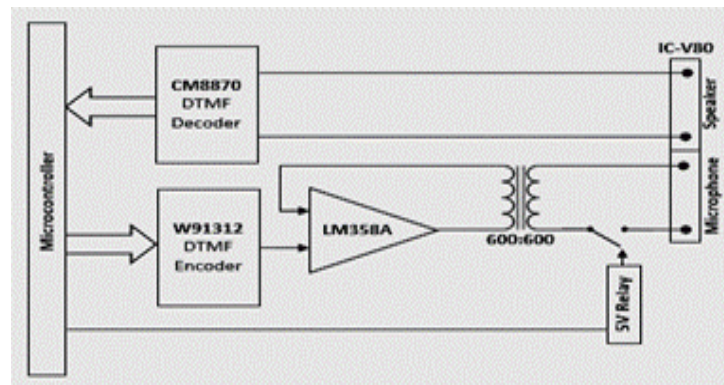

(d)

Figure 2. (a) Flow diagram of the Command Center, (b) User-Defined Protocol for sending a request, (c) The ICOM IC-V80 Two-way Radio transceiver, (d) Diagram of the DTMF converter

2.2. Remote monitoring station (RMS)

The RMS has a set of sensors, a microcontroller, DTMF converter and a transceiver. These are shown in the block diagram illustrated in Figure 3(a). The microcontroller used is the PIC16F877A, the same microcontroller used in the implementation of the CC. The DTMF converter in the RMS is also similar to the one used in the CC. A small LCD display is provided in the RMS for function monitoring purposes. Dip switches are used to specify the identification of each RMS. Each RMS essentially waits for a command from the CC, or relays sensor data from other RMSs to eventually reach the CC. When a command is received, the RMS determines if the command or data is intended for it. If not, it simply ignores the data. If the command is intended for that remote station, the station will collect sensor data and send the collected data to the CC. Figure 3(b) illustrates the flow diagram of the RMS. Each RMS also uses a UDP for the transmission of sensor data and is shown in Figure 3(c). It is composed of the following fields: origin, next, destination and the data. The first three fields are basically the same as the ones used in the CC and were described above. The data field utilizes a total of 56 bits to transmit the following sensor data: temperature, rainfall, wind speed, wind direction and water level. To monitor the battery voltage, also transmitted and monitored is the supply voltage using 12 bits for a total transmitted data of 68 bits.

In the implementation of the prototype, the temperature sensor used is the LM35. It is an IC-based temperature sensor having an output voltage directly proportional to the temperature. It can measure temperature ranging from -55°C to 150°C and does not require an external calibration to meet the $\pm 3/4^{\circ}\text{C}$ accuracy. When used in the system, the average error (out of 5 trials) is 0.2% around the reference temperature of 20°C .

The water level sensor in the prototype uses six (6) float switches placed 6 inches apart inside a rectangular enclosure. Also, the distance from the ground to the first float switch is 6 inches. The enclosure has a small hole at the bottom to allow water to enter the water level sensor. The float switches are connected to a pull-up resistor via a series of resistors. The circuit diagram of the water level sensor is shown in Figure 3(d). The voltage at RA1 is used to determine the water level and is equal to the voltage drop across the total resistance below RA1. This total resistance is in series with the $10\text{ k}\Omega$ resistor directly connected to the source, forming a voltage divider network. Since float switches are 6 inches apart, the accuracy is also within this range. In practice for flood monitoring, this accuracy is acceptable.

The rain gauge sensor used in the prototype is a small rain gauge from PRONAMIC and is composed of a pull-up resistor of $10\text{ k}\Omega$ and a reed switch. Every time the reed switch is turned closed, a pulse is sent to the microcontroller. The sampling period of the rain gauge is set to one hour. The rain gauge used in prototype is an industry type, so its accuracy is within the acceptable values.

The anemometer used in the prototype is from Davis Instruments. It also has a $10\text{ k}\Omega$ pull-up resistor and a reed switch. Every time a revolution is completed, the reed switch closes sending a pulse to the microcontroller. The sampling period is set at 2.25 seconds and the unit is set at miles per hour. This anemometer has an error of about 0.2% at a wind speed of 50 mph.

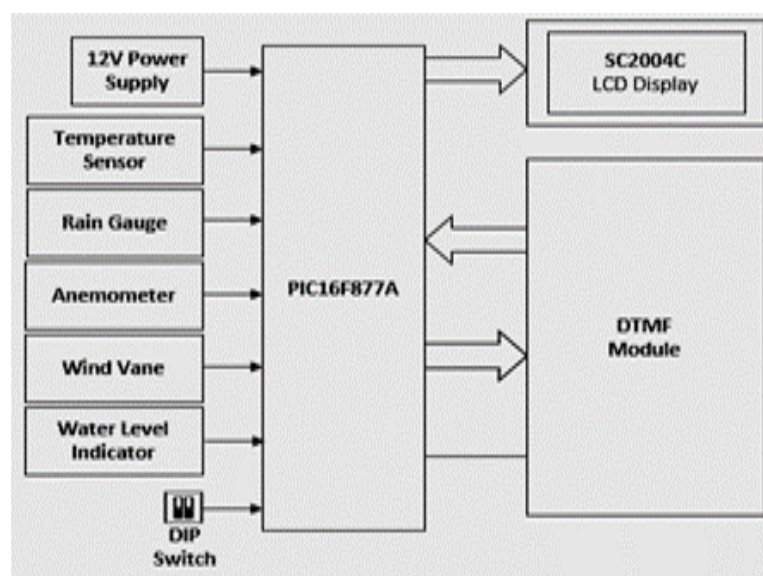

(a)

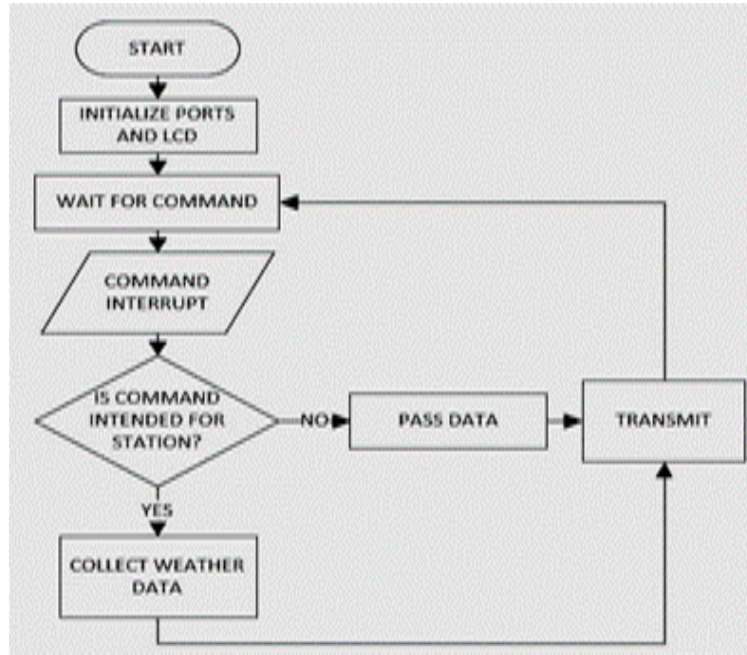

(b)



(c)

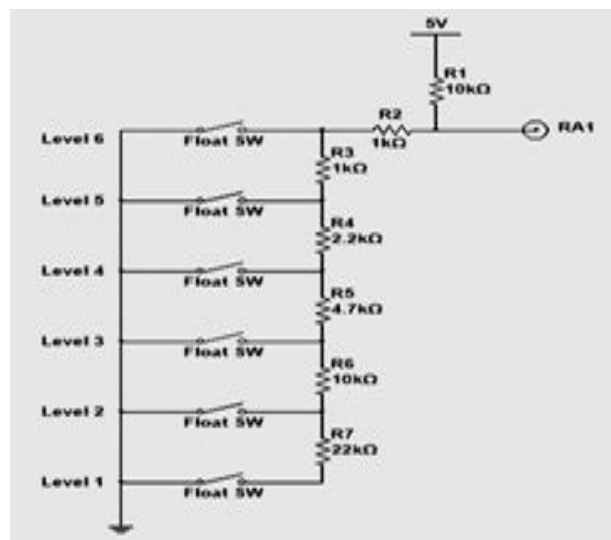

(d)

Figure 3. (a) Block Diagram of the remote monitoring station, (b) general Flowchart for the remote monitoring stations, (c) user-defined protocol for sending back the data collected, (d) circuit diagram of the water level sensor

3. RESULTS AND DISCUSSION

The proposed system is constructed, implemented and tested with a CC and three (3) RMSs. Figure 4(a) shows the CC, the three RMSs and some of the sensors in a thesis exhibit. Not shown in the image is the computer. Figure 4(b) shows the electronic parts of the CC. Observe the presence of the three push buttons on the front right part of the CC. These are the buttons used for the manual sending of request for sensor data from the CC to the RMSs. The internal parts of the RMSs are shown in Figure 4(c). Each RMS unit is provided with an LCD (liquid crystal display) for easy testing and troubleshooting at the remote location. Figure 4(d) shows such a display. It displays some sensor data and some codes received and transmitted by the unit.



Figure 4. Prototype of the proposed monitoring system

The system was tested in an open area along the sea wall of Manila with varying distances between units with three trials for each distance value. The tests aim to demonstrate the ability of the system to (1) send request for sensor data by the CC to the destined RMS, (2) send sensor data to the CC by each of the RMSs and (3) determine the distance limitation of the system. The tests involve a CC and three remote stations with all transceivers: placed in upright position; having a transmitter output power of 5.5 watts; and elevated one meter above the ground level. Prior to these range tests, all sensors are properly calibrated using standard procedures and with accuracies within acceptable limits. In the range tests, the transceivers use the omnidirectional rubber ducky antenna that come with the transceiver upon purchase. Table 1 shows the results of these tests. The successful entries mean that, in at least two of the three trials, the sensor data are successfully received by the CC. Unsuccessful entries mean that there are at least two unsuccessful reception of sensor data at the CC out of the three trials. The table shows that with the rubber ducky antenna, the system is able to operate with a node distance of up to 900 meters. For applications requiring greater distances between nodes, e.g. inter-city or inter-town, high gain and directional antennas should be installed. The use of high gain antennas will improve the range of the system, higher than the 1300-meter range set by the system described in [3]. Based on existing VHF two-way communications systems and with the proper antenna gain and elevation, a node distance of 30-40 km can be achieved easily.

Table 1. Range test results on the prototype of the proposed system

Node Distance (meters)	CC-RMS1	RMS1-RMS2	RMS2-RMS3
100	Successful	Successful	Successful
200	Successful	Successful	Successful
300	Successful	Successful	Successful
400	Successful	Successful	Successful
500	Successful	Successful	Successful
600	Successful	Successful	Successful
700	Successful	Successful	Successful
800	Successful	Successful	Successful
900	Successful	Successful	Successful
1000	Unsuccessful	Unsuccessful	Unsuccessful
1100	Unsuccessful	Unsuccessful	Unsuccessful
1200	Unsuccessful	Unsuccessful	Unsuccessful

During successful transmission of ‘request for data’ from CC and its eventual reception of data, the received current sensor data from RMSs are displayed in the GUI. A sample of such display is shown in Figure 5(a) with the current sensor data from RMS3 being displayed. In the figure, the immediate sensor data as well as the battery voltage of each of the three RMS are also shown in the display. The tests were conducted sometime in July 21, 2017. Figure 5(b) shows a screen shot of a sample log of the previous sensor data from the three remote monitoring stations which were logged in Excel file after being displayed in the GUI.



(a)

	A	B	C	D	E	F	G	H	I
1	Date	TIME	STATION	TEMP	RAIN	WIND	DIRECTIO	LEVEL	VOLTAGE
2	7/21/2017	1:10:29 AM	1	30.9	0	1	W	4	11.2
3									
4									
5	7/21/2017	1:12:46 AM	2	2.5	0	0	NW	0	11.6
6									
7									
8	7/21/2017	1:15:03 AM	3	13.1	0	0	NW	0	1
9									
10									
11	7/21/2017	1:20:30 AM	1	32	0	0	W	4	11.2
12									
13									
14	7/21/2017	1:22:47 AM	2	2.4	0	0	NW	0	11.6
15									
16									
17	7/21/2017	1:25:03 AM	3	13.1	0	0	NW	0	18
18									
19									
20	7/21/2017	1:30:30 AM	1	31.1	0	5	W	4	11.2
21									
22									
23	7/21/2017	1:32:47 AM	2	2.3	0	0	NW	0	11.6
24									
25									
26	7/21/2017	1:35:03 AM	3	32	0	7	N	1	8

(b)

Figure 5. Sample GUI display at the command center showing sensor data and other information, (b) sample log in Excel format of the previous sensor data from the three remote monitoring stations

The main advantage of the proposed system with the previously developed monitoring systems is its range due to the lower operating frequency and higher transmitter power. The proposed system is also easier to maintain since it makes use of locally available components. Compared to the AWS, the proposed system is better on reliability and availability, and on cost. Based on the results of the tests conducted, the proposed system can find applications such as the ones described in [9-11] or any system that involves the transmission of any data [12, 13]. The systems described in [14-16] are recommended for the proposed system’s optimization on features and energy efficiency. Other modes of transmissions are described in [17-25].

4. CONCLUSION

The system just presented was proposed with the aim of developing a remote monitoring system (1) capable of withstanding extreme weather and other conditions, (2) that is low cost, and (3) that promotes the utilization of locally available components. It serves as a low-cost, an easy-to-deploy and a robust system to monitor the weather and its effects, especially for extreme weather conditions. Monitoring the weather comprehensively, in real-time and in the local government level allows concerned government agencies to formulate actions for relief and risk reduction in affected areas. The use of VHF radio transceivers in the prototype for the sending and reception of requests and sensor data is effective up to 900 meters between nodes with the use of omnidirectional antennas. The addressing issue and scalability feature were managed in

the proposed system with the use of the user-defined protocol. The scalability feature extends the coverage area of the monitoring system by increasing the number of monitoring stations. This is done by increasing the number of bits in the identification of each node. In the prototype, there are four bits used which allows the number of RMSs to a maximum of 16 (24). The minimum length of time sensor data should be transmitted regularly should also be considered as discussed earlier. However, the proponents recommend the use of an error control scheme in the transmission and reception of data to improve the reliability of the system. Also, the use of directional, high gain and elevated antennas to increase the distance between stations is recommended. The proponents further recommend the use of the proposed system in the transmission of data from sensors in various applications. The system may also find applications in monitoring seismic activities, landslide, civil structural health, groundwater level and contamination, industrial process, and automated building climate control. Further, the authors would like to recommend for future works the optimization of some of the features of the system and in making it more energy efficient.

REFERENCES

- [1] Asian Disaster Reduction Center (ADRC), "Details of disaster information," [Online]. Available: <http://www.adrc.asia/nationinformation.php?NationCode=608&Lang=en&NationNum=14> [Accessed on Mar 23, 2018.]
- [2] Ghio Ong, H. Flores, "PAGASA installs new automated weather stations," Philstar, April 27, 2011. [Online]. Available: <http://www.philstar.com/nation/679477/pagasa-installs-new-automated-weather-stations?nomobile=1> [Accessed on Mar 23, 2018]
- [3] C. F. Aragonés, P. D. R. Elpa, D. M. Pangan, Q. Santos, and G. Mappatao, "Scalable remote water monitoring system using radio frequency links," *Theory and Applications of Applied Electromagnetics*, Springer, International Publishing Switzerland, pp. 13-23, 2016.
- [4] M. G. Dioso, R. U. Inocencio, B. G. Macaspac, and J. F. Ocampo, "Profiling the Performance of the Scalable RF Link for Data Transmission of Multi-Node Automated Weather Station," Undergraduate thesis, De La Salle University, Dec 2010.
- [5] X. Wang, Y. Gao, "A switch-modulated method for chaos digital secure communication based on user-defined protocol," *Communications in Nonlinear Science and Numerical Simulation*, vol. 15, no. 1, pp. 99-104, 2010.
- [6] A. Djimli, S. Merniz, S. Harous, "Energy-efficient MAC protocols for wireless sensor networks: A survey," *TELKOMNIKA (Telecommunication, Computing, Electronics and Control)*, vol. 17, no. 5, pp. 2301-2312, 2019.
- [7] M. Oliaei, M. H. Noranian, "Design of GPS-GPRS Delivering Data System Using UDP Protocol," *Cyber Journals: Multidisciplinary Journals in Science and Technology, Journal of Selected Areas in Telecommunications (JSAT)*, vol. 4, no. 1, pp. 9-14, 2014.
- [8] H. Harb, A. Makhoul, A. Jaber, R. Tawil, O. Bazzi, "Adaptive data collection approach based on sets similarity function for saving energy in periodic sensor networks," *International Journal of Information Technology and Management*, vol. 15, no. 4, pp. 346-363, 2016.
- [9] S.C.J. Palmer, T. Kutser, P.D. Hunter, "Remote sensing of inland waters: challenges, progress and future directions," *Remote Sens Environ*, vol. 157, pp. 1-8, 2015.
- [10] G. Bitella, R. Rossi, R. Bochicchio, M. Perniola, M. Amato, "A novel low-cost open-hardware platform for monitoring soil water content and multiple soil-air-vegetation parameters," *Sensors*, vol. 14, pp. 19639-19659, 2015.
- [11] S. Parjuangan, R. Ali, Ari Purnama, "Real-time monitoring and warning system in urban rivers," *TELKOMNIKA (Telecommunication, Computing, Electronics and Control)*, vol. 17, no. 3, pp. 1521-1525, 2019.
- [12] I.M.Z. Bautista, M.K. Orsos, M.A. Ribo, L. Castillo, G. Mappatao, "Development of a remote tending system for analog broadcast transmitters," *Indonesian Journal of Electrical Engineering and Computer Science (IJECS)*, vol. 15 no. 3, pp. 1474-1484, 2019.
- [13] I.M.Z. Bautista, M.K. Orsos, M.A. Ribo, L. Castillo, G. Mappatao, "Remote Tending of Modern Broadcast Transmitters," *Indonesian Journal of Electrical Engineering and Computer Science (IJECS)*, vol. 15 no. 3, pp. 1491-1500, 2019.
- [14] M. Emre Keskin, I. Kuban Altinel, Necati Aras, Cem Ersoy, "Wireless sensor network design by lifetime maximisation: an empirical evaluation of integrating major design issues and sink mobility," *Int. J. of Sensor Networks*, vol. 20, no.3 pp. 131-146, 2016.
- [15] N. Verma, M. Nimesh, R. Rani, "Energy-efficient sensor optimisation in wireless sensor networks," *International Journal of Wireless and Mobile Computing*, vol. 9, no.4, pp. 355-362, 2015.
- [16] H. Ghamgin, "Address-light and energy aware routing protocol for wireless sensor network," *TELKOMNIKA (Telecommunication, Computing, Electronics and Control)*, vol. 17, no. 4, pp. 1674-1682, 2019.
- [17] G.P. Mappatao, "Radiation pattern shaping for FM broadcast-optimizing coverage," in *ISIEA 2010 - 2010 IEEE Symposium on Industrial Electronics and Applications*, 5679465, pp. 222-225, 2010.
- [18] G.P. Mappatao, "Reducing the downward radiation of slanted dipole array," in *ISIEA 2010 - 2010 IEEE Symposium on Industrial Electronics and Applications*, 5679454, pp. 290-294, 2010.
- [19] M. Oliaei and M.H. Noranian, "Design of GPS-GPRS Delivering Data System Using UDP Protocol," *Cyber Journals: Multidisciplinary Journals in Science and Technology, Journal of Selected Areas in Telecommunications (JSAT)*, vol. 4, no. 1, pp. 9-14, 2014.

- [20] G.P. Mappatao, "Reducing FM broadcast energy consumption using directional radiation pattern," *ARNP Journal of Engineering and Applied Sciences*, vol. 10, no. 15, pp. 6484-6490, 2015.
- [21] F.S. Caluyo, G. Mappatao, "Azimuth radiation pattern shaping and control for FM broadcast," *International Journal on Communications Antenna and Propagation*, vol. 1, no. 3, pp. 284-289, 2011.
- [22] G.P. Mappatao, "Radiation characteristics of patterns derived from shunt-fed slanted dipole linear arrays," *International Journal on Communications Antenna and Propagation* vol. 6, no. 3, pp. 138-145, 2016.
- [23] F.S. Caluyo, G. Mappatao, "Optimizing FM broadcast coverage using hybrid optimizations," *International Journal on Communications Antenna and Propagation*, vol. 1, no 5, pp. 439-445, 2011.
- [24] G. Mappatao, "Compliance to broadcast standards of patented broadcast antennas: The circularly polarized Antenna," *International Journal on Communications Antenna and Propagation*, vol. 7, no.2, pp. 154-161, 2017.
- [25] G. Mappatao, "The compliance to broadcast standards of a side-mounted circularly polarized antenna," *International Journal on Communications Antenna and Propagation*, vol. 8, no. 3, pp. 240-247, 2018.

BIOGRAPHIES OF AUTHORS



Maria Lynn Carbonell received the B.S. degree in electronics and communications engineering from De La Salle University, Manila, Philippines in 2017. She is a licensed Electronics Engineer in the Philippines and currently works as a Systems Engineer at Genesys, a company that provides contact center solutions.



John Michael Carpio received the B.S. degree in electronics and communications engineering from De La Salle University, Manila, Philippines in 2017. He currently works as an Application Development Associate at Accenture Inc. He is a licensed Electronics Engineer in the Philippines.



Juan Carlo Medina, an alumnus of De La Salle University - Manila with a degree of B.S. in electronics engineering. He is a licensed Electronics Engineer and Electronics Technician in the Philippines and is currently affiliated with Grab Philippines, a leading everyday application in the transport network vehicle service in South-East Asia. He specializes in the Change and Transformation of the city operations of Grab.



John Paul Perote received the B.S. degree in electronics and communications engineering from De La Salle University, Manila, Philippines in 2017. He worked at Accenture as Application Development Associate in Workday, a cloud-based application for human and financial management.



Tristian Jhan J. Tamayo born on January 11, 1993. He received the B.S. degree in electronics and communications engineering from De La Salle University, Manila, Philippines in 2017. He currently works as an App/Cloud Support Analyst at Accenture, Philippines.



Gerino P. Mappatao was born in Tuao, Cagayan, Philippines. He received the B.S. degree in electronics and communications engineering (ECE) from Saint Louis University, Baguio City, Philippines in 1989, the M.S. and PhD degrees in ECE from De La Salle University-Manila, Philippines in 1998 and 2012, respectively. He is currently an Associate Professor of Electronics and Communications Engineering at De La Salle University-Manila. He authored and co-authored papers in conference proceedings and journals on antennas, broadcast engineering, wireless communications and image processing.