

Comparative study of three different bridge-less converters for reduction of harmonic distortion in brushless DC motor

Santanu Mondal¹, Madhurima Chattopadhyay²

¹Department of Electronics and Instrumentation Engineering, Techno India, Salt Lake, India

²Department of Applied Electronics and Instrumentation Engineering, Heritage Institute of Technology, India

Article Info

Article history:

Received Jan 15, 2020

Revised Apr 18, 2020

Accepted Jun 2, 2020

Keywords:

BLDCM

Flyback

SEPIC

Total Harmonic Distortion

Zeta

ABSTRACT

This paper represents a comparative study of three different types of DC-DC converter that can be used for reduction of Total Harmonic Distortion (THD) in stator current, back electromotive force (EMF) and torque of brush less DC motor. In addition, the topologies of these converters are analysed, and the THD of the output characteristics have also been studied. In this work, SEPIC, Zeta and Flyback converters are considered and their outputs are fed to the BLDCM with the help of universal bridge or six step inverter. Moreover the THD of the output voltages are not only measured for three converters but also reduced by tuning the parameters. At first these three converters are modeled in MATLAB/Simulink based simulation platform and studied the performance individually and further executed with hardware circuitry. Finally the output parameters from both software simulation and real time hardware are compared for these three converters separately and got satisfactory similar results. Again we studied the performance with these converters in terms of efficiency while fed in the commutation drive circuitry of BLDCM by considering minimum THD. From this comparative simulation results, it has been observed that Zeta converter showed maximum efficiency. Therefore, in real time hardware implementation, the commutation drive circuitry of BLDCM is studied with Zeta converter. With this configuration, a comparatively low THD of stator current, back EMF and electromagnetic torque have been achieved in BLDCM with PID controller.

Copyright © 2020 Institute of Advanced Engineering and Science.
All rights reserved.

Corresponding Author:

Santanu Mondal,

Department of Electronics and Instrumentation Engineering, Techno India,

Salt Lake, Kolkata-700091, West Bengal (India), India.

Email: santanu_aec1984@yahoo.co.in

1. INTRODUCTION

Brushless DC motors have become increasingly popular in the past decade due to their wide range of industrial and commercial applications such as aerospace, automotive, health sector etc. [1-2]. They dominate in household appliances like refrigerators, ventilation fans, hairdryers, washer, coffee machines, air-conditioners, pump etc. because they are light in weight with less maintenance. On the other hand, they have high power density with high efficiency due to better electro-mechanical energy conversion [3-4]. This result in a remarkable reduction in the power required for its operation [5]. Moreover, BLDC motors are popular because of its bi-directional operation, variable speed control, compact size and low maintenance. To drive BLDC motor, a separate electronic commutation circuit is essential and the extensively used

commutation methods for the drive are field oriented control (FOC), sinusoidal and trapezoidal [6]. The field oriented control is suitable for both wide speed and precise control of electromechanical torque and rotor speed. But it is not generally used for its complex design and higher processing requirements. The sinusoidal commutation requires high resolution position feedback devices, such as optical encoder. It also generates more noise and affects the commutation sequence resulting in poor performance of the motor. The trapezoidal commutation also known as six step commutation, is the simplest form of commutation which is available to control the BLDC motor. This commutation technique is very popular because of its simple control algorithm and low-cost [7]. This commutation requires a high value of the DC-link capacitor and a voltage source inverter (VSI), which introduces both torque ripple and high harmonic distortion. So in order to minimize the torque ripple as well as harmonic distortion, different bridge-less converter topologies are studied. In practical purposes, both full bridge and bridge-less converter based topologies are employed. It has been observed through literature review, that the bridge-less topologies are more popular in BLDC drive and a few such commonly used converters are Cuk, Flyback, SEPIC, Sheppard Taylor, Zeta etc. for initiating the corrective action in Harmonic Distortion and torque ripple.

Cuk converter is a type of converter which can be used to minimize the ripple from output due to the presence of L-C circuit [8]. Flyback converter is used for converting DC power supply in the low power range efficiently and provides isolation between primary and secondary with multiple outputs. Thus, the transformer module of a Flyback converter is also described as coupled inductor and produces a choice of positive or negative voltage for the output [9]. SEPIC offers the input-to-output gain in non-inverting mode, thus making it popular in power systems. This is achieved by using a series capacitor to couple energy from the input to the output. Sheppard-Taylor converter receives wide attention due to its ability of good voltage regulation, high power factor and less harmonics for low-voltage ranges. Again Zeta converter is a fourth order converter that uses less number of switches compared to others. Zeta also offers additional safety against over current and inrush current as compared to other converter topologies. Hence, in low power applications, zeta converter is more advantageous over other DC-DC converters [10]. In the scope of this work, we have considered Flyback, SEPIC and Zeta converters owing to their low power handling capacity for wide range of applications [11]. This paper is organized into five sections. The first section gives a brief introduction to BLDC drives. The next section details the mathematical model of Brushless DC motor drive. In the third section, the operations of three Converters are explained with software simulation followed by real time hardware circuitry and compared both outputs. The comparative result shows that the most suitable outputs is coming from zeta converter. Thus, the next section comprises of design, MATLAB/Simulink model simulated results and real life implemented hardware circuitry for Zeta converter fed six step commutated BLDC motor drive. The fifth section concludes the work.

2. MATHEMATICS OF THE BRUSHLESS DC MOTOR

A schematic diagram of a brushless DC motor drive is shown in Figure 1. The modelling of brushless DC motor involves solving many differential equations. The equations shown in the latter part of this paper are based on this system. A few assumptions are made in order to reduce the mathematical complexity of the brushless DC motor drive. There are symmetrical three-phase winding, no magnetic saturation, no hysteresis and eddy current losses, uniform air-gap, mutual inductance is ignored, and armature reaction is ignored in BLDC motor. The back EMF is displaced by 120 electrical degrees from one phase to another [12-13]. The per phase voltage (V_{an} , V_{bn} and V_{cn}) expression with respect to neutral terminal (n) as follows:

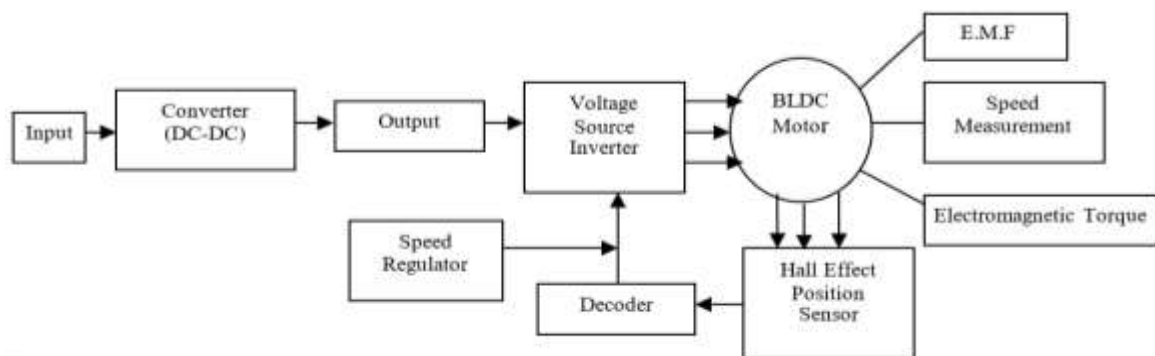

Figure 1. Block diagram of BLDC with DC-DC converter

$$V_{an} = R_s i_{an} + L \frac{d}{dt} i_{an} + M \frac{d}{dt} (i_{bn} + i_{cn}) + e_{an} \tag{1}$$

$$V_{bn} = R_s i_{bn} + L \frac{d}{dt} i_{bn} + M \frac{d}{dt} (i_{cn} + i_{an}) + e_{bn} \tag{2}$$

$$V_{cn} = R_s i_{cn} + L \frac{d}{dt} i_{cn} + M \frac{d}{dt} (i_{an} + i_{bn}) + e_{cn} \tag{3}$$

where i_{an} , i_{bn} and i_{cn} represents three phase stator currents, R_s , M and L_s are the phase resistance, the mutual inductance and self-inductance of the stator’s winding of BLDC motor respectively. e_{an} , e_{bn} and e_{cn} represent back emf of BLDC motor.

The electromagnetic torque (T_e) produced by BLDC motor can be expressed as

$$T_e = \frac{\sum(e_{an}i_{an})}{\omega} \tag{4}$$

Where, ω represents speed of the rotor.

The back EMF of the said motor can expressed in terms of function of rotor position(θ), speed of rotor (ω) and flux linkage (λ).

$$e_{an} = f_{an}(\theta)\omega\lambda_x \tag{5}$$

Substituting (5) in (4), again the electromagnetic torque can be consider as

$$T_e = \lambda_x \sum f_{an}(\theta) i_{an} \tag{6}$$

The average power of phase ‘a’ is given as

$$P_a = \frac{1}{\pi} \int_0^{\pi} e_a i_a d\theta \tag{7}$$

3. GENERALIZED DC-DC CONVERTERS

There is a variety of DC-DC converters available in market. From them SEPIC and Zeta, non-isolated converters and Flyback, isolated converter are described in presence scope of work for their simple circuitry and easy to implement and they are mainly used in SMPS (Switch Mode Power Supply). Figure 2 shows simple DC-DC converter. In various domestic and industrial applications it’s required to transform a fixed dc voltage into variable dc voltage. It is widely used in hybrid vehicles, portable electronics devices, aerospace etc.

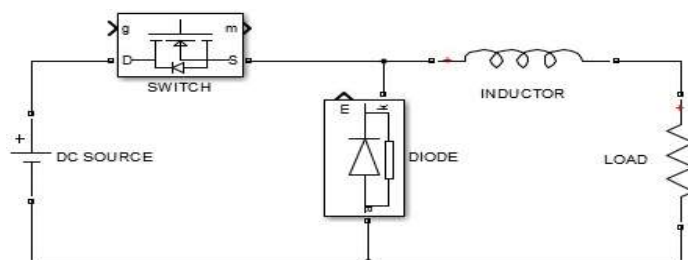

Figure 2. Simple DC-DC converter

3.1. SEPIC Converter

The single ended primary inductor converter (SEPIC) is a type of DC-DC converter that allows the electrical potential at its output to be greater than, less than or equal to its input. It can act as a step-up or step-down converter, depending on the value of Duty cycle (D) of the control transistor. Basic circuit of SEPIC converter is shown in Figure 3. The elementary circuit of the SEPIC converter consists of a DC power supply and a diode D [14]. The energy storage elements are C_i , C_o which represents input and output capacitor respectively and L_i , L_o represents input and output inductor correspondingly [15]. R is the load resistance. V_{in} and V_o are the input and output voltages of SEPIC converter respectively. Capacitors with low equivalent

series resistance (ESR) should also be used for C_i and C_o to minimize ripple and prevent heat build-up, especially in C_i where the current is changing direction frequently. ΔI_{Li} and ΔI_{Lo} represents change in input and output inductor current respectively. ΔV_{Ci} and ΔV_{Co} represents change in voltage drop of input and output capacitor correspondingly. Table 1 shows the output voltage and current of the said converter from both simulation and experimental studies.

Table 1. Output voltage & current of SEPIC converter

Serial No.	Input parameters		Output parameters			
	Voltage(Volt)	Current(mA)	Simulation		Experimental	
			Voltage(Volt)	Current (mA)	Voltage(Volt)	Current(mA)
1.	5	4348	8.944	178	9.285	185
2.	6	5226	10.88	217	11.14	228
3.	7	6104	12.82	256	13.00	26
4.	8	6982	14.77	295	14.85	297
5.	9	7860	16.71	334	16.71	334
6.	10	8738	18.65	373	18.57	371
7.	11	9616	20.59	411	20.42	408
8.	12	10490	22.54	450	22.28	445
9.	13	11370	24.48	489	24.14	482
10.	14	12250	26.42	528	26.00	521

$$\text{Output Voltage: } V_0 = \frac{D}{1-D} V_{in} \tag{8}$$

$$\text{Inductor Selection: } L_i = \frac{V_{in} - D}{\Delta I_{Li} f_s} D \tag{9}$$

$$L_o = \frac{V_o}{\Delta I_{Lo} f_s} (1 - D) \tag{10}$$

Where, f_s = Switching Frequency.

$$\text{Capacitor Selection: } C_i = \frac{D}{R f_s} \left(\frac{V_o}{\Delta V_{Ci}} \right) \tag{11}$$

$$C_o = \frac{D}{R f_s} \left(\frac{V_o}{\Delta V_{Co}} \right) \tag{12}$$

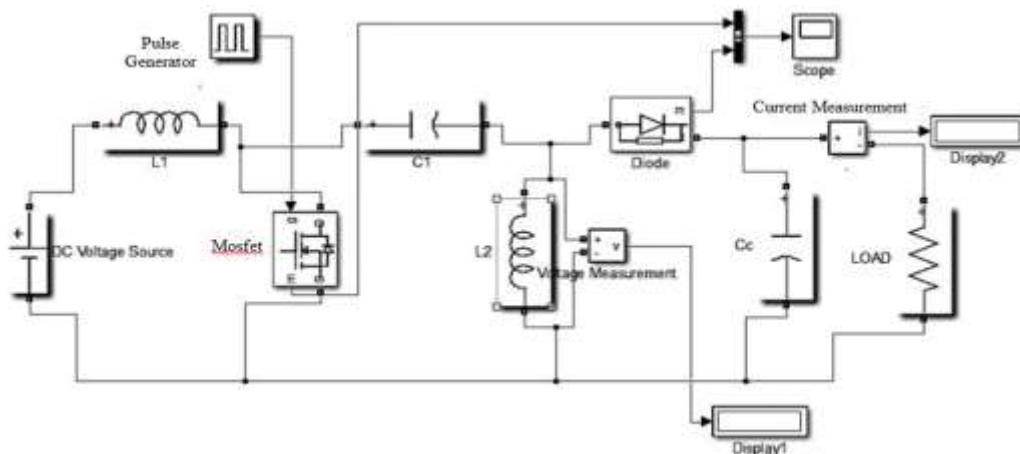

Figure 3. SIMULINK model of sepic converter

3.2. Zeta Converter

The Zeta converter is another converter topology to provide a regulated output voltage from an input voltage that varies above and below the output voltage. The advantage of the Zeta converter over the SEPIC converter are lesser ripple in output voltage and better THD in output voltage [16]. This converter can be

operated either Continuous Conduction Mode (CCM) or Discontinuous Conduction Mode (DCM). Continuous Conduction Mode uses a complex current multiplier method and requires three sensors (one-current and two-voltage sensor) for power factor correction (PFC) control [17-19]. Whereas, DCM uses a simple approach for PFC control, which requires only one voltage sensor. A DCM is ideal for a low and medium power rating, whereas CCM is used for high power ratings. In this paper zeta converter is designed Discontinuous Conduction mode.

The equation of output voltage (V_0), input inductance (L_i), output inductance (L_0) and input capacitance (C_i) are same as SEPIC converter as given in (12). The basic circuit model of Zeta converter is shown in Figure 4 and Table 2 shows the output voltage and current of said converter. Figure 4 represents Zeta converter fed BLDC motor drive with PID controller for desired performance. Again both the simulation and experimental results are studied. The output capacitance (C_0) is given as

$$C_0 = \frac{1-D}{8L_0f_s^2} \left(\frac{V_0}{\Delta V_{CO}} \right) \tag{13}$$

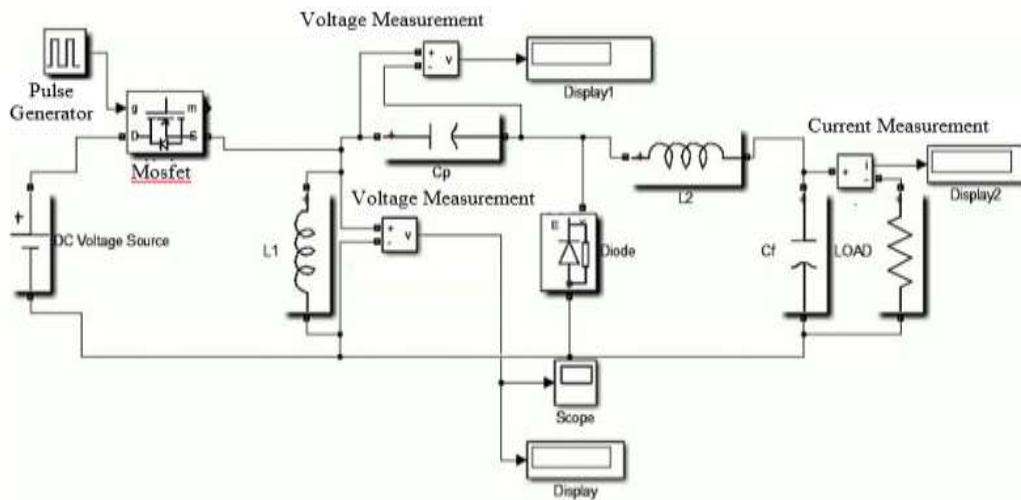

Figure 4. SIMULINK model of zeta converter

3.3. Flyback Converter

Flyback converter is most commonly used switch Mode Power supply circuit for medium power output applications where the output voltage needs to be isolated from the input main supply. The output power of flyback type converter may vary from few watts to less than 200 watts [20-23]. This converter can provide single/multiple isolated output voltages and can run over comprehensive input voltage variation. This converter has its simple topology and low cost makes it popular in low or medium output power range. The commonly used fly-back converter requires a single controllable switch like MOSFET and the usual switching frequency is in the range of 100 kHz. A simple flyback converter is shown in Figure 5 [24]. Unlike AC transformer which needs concurrently energy transfer, it has to store energy in magnetizing inductance when the switch is on and transfer it to the secondary side when the switch is off. Hence the transformer magnetizing inductance is designed to be more in this type of converter, to be able to store some amount of energy. It can be operated discontinuous conduction mode (DCM) where primary current reaches zero compared to the continuous current mode (CCM). The DCM has better efficiency, fast transient response and smaller transformer [25]. Table 3 shows the output voltage and current of the flyback converter and compare simulation and theoretical result. The output voltage (V_0) and capacitance are shown in (14) and (15) respectively. Figure 6 shows the output of flyback converter in FFT mode. Comparative study of three different types of converters are given in Table 4 and Table 5 shows the parameters used in our experiment.

$$\text{Output Voltage: } V_0 = \frac{D}{1-D} \left(\frac{N_2}{N_1} \right) V_{in} \tag{14}$$

$$\text{Capacitor Selection: } C_0 = \frac{D}{Rf_s} \left(\frac{V_0}{\Delta V_{CO}} \right) \tag{15}$$

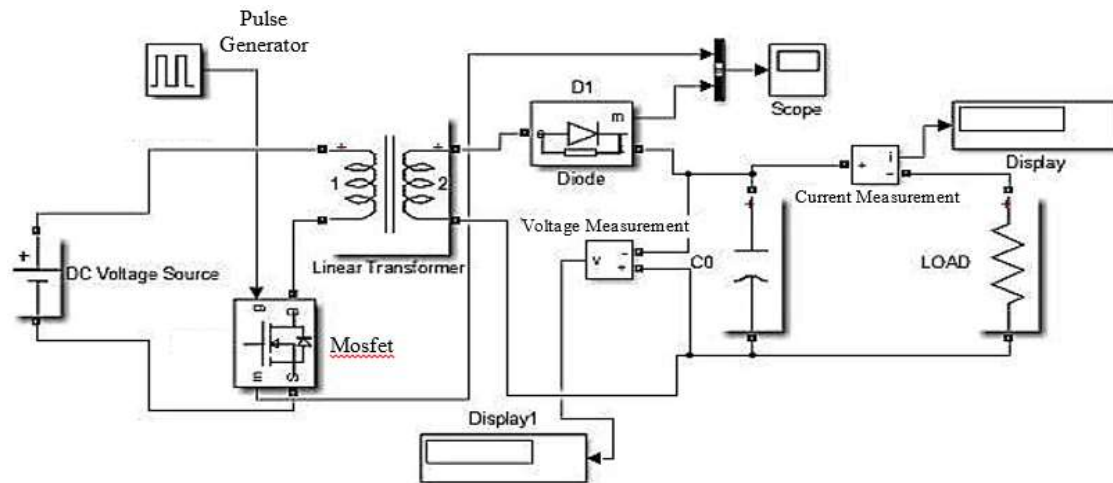

Figure 5. SIMULINK model of flyback converter

Table 2. Output voltage & current of zeta converter

Serial No.	Input parameters		Output parameters			
	Voltage(Volt)	Current(mA)	Simulation		Experimental	
			Voltage(Volt)	Current(mA)	Voltage(Volt)	Current(mA)
1.	8	0.263	18.33	458	18.66	466
2.	10	0.329	23.07	576	23.33	580
3.	15	0.4927	34.92	872	35	875
4.	20	0.6583	46.77	1169	46.66	1166
5.	25	0.8199	58.62	1465	58.33	1458
6.	30	0.9834	70.47	1762	70	1750
7.	35	1.147	82.32	2058	81.66	2041
8.	40	1.311	94.17	2354	93.33	2333
9.	45	1.474	106	2650	105	2625
10.	50	1.638	117.9	2947	116.66	2916

Table 3. Output voltage & current of flyback converter

Serial No.	Input parameters		Output parameters			
	Voltage(Volt)	Current(mA)	Simulation		Experimental	
			Voltage(Volt)	Current(mA)	Voltage(Volt)	Current(mA)
1.	10	13.97	5.701	25.92	6.42	24
2.	11	15.69	6.402	29.1	6.864	30
3.	13	19.14	7.804	35.47	8.34	37
4.	15	22.5	9.2	41.84	9.63	43
5.	16	24.3	9.907	45.09	10.272	46
6.	19	26	10.61	48.2	10.914	49
7.	20	29.48	12.01	54.5	12.198	55
8.	21	31.2	12.71	57.7	12.84	58
9.	23	32.9	13.41	60.9	13.482	61.2
10.	25	63.8	14.81	67.3	14.76	67.1

4. RESULTS AND DISCUSSIONS

From Figure 3 we get the output voltage waveform of SEPIC converter. The FFT analysis of the D.C. output voltage is done for SEPIC converter and shown in Figure 6. From the Figure 4 we get the output voltage waveform of Zeta converter. The FFT analysis of the D.C. output are done for Zeta converter and shown in Figure 7. Here Supply Voltage is 20 Volts. We have selected 1 cycle. From Figure 5, we get the output voltage waveform of Flyback converter. The FFT analysis of the D.C. output Voltage is considered for Flyback converter and shown in Figure 8. For applying the 20 volt. Input, the output voltages are displayed the back EMF for three Converters. Figure 9, 10 and 11 represents the back EMF FFT analysis of SEPIC, Zeta and Flyback fed BLDC motor respectively. Figure 12 and 13 depicts the stator current and electromagnetic torque of BLDC fed Zeta converter correspondingly. Finally the hardware implementation of Zeta converter fed BLDC motor shown in Figure 14 and 15.

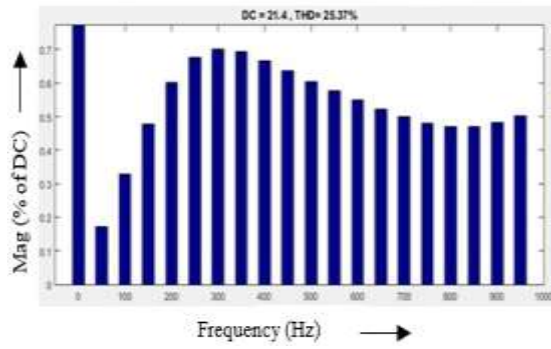

Figure 6. SEPIC converter FFT analysis

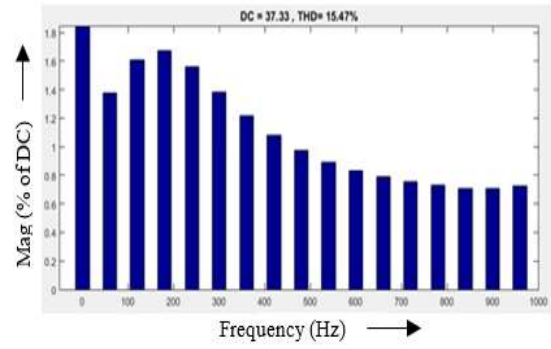

Figure 7. Zeta converter FFT analysis

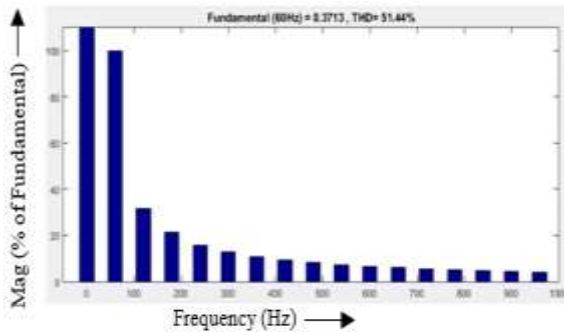

Figure 8. Fly back converter FFT analysis

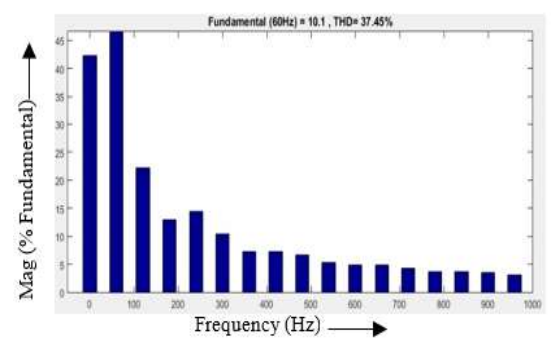

Figure 9. Back EMF of SEPIC fed BLDC motor

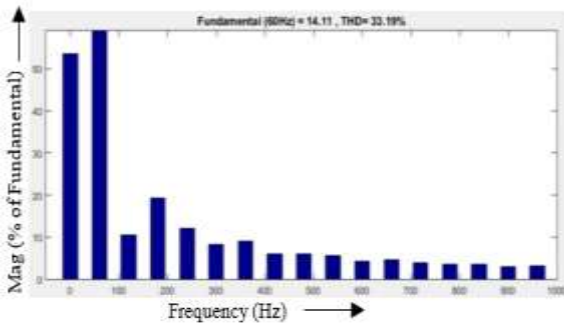

Figure 10. Back EMF of zeta fed BLDC

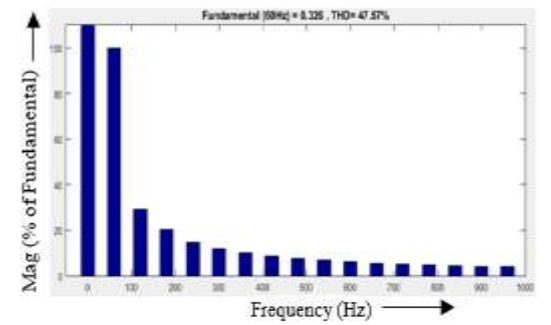

Figure 11. Back EMF of flyback fed BLDC

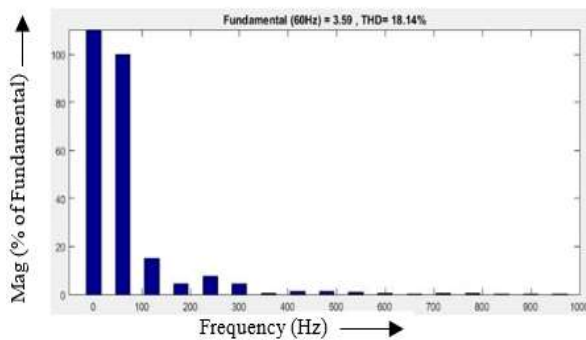

Figure 12. Stator current of zeta fed BLDC

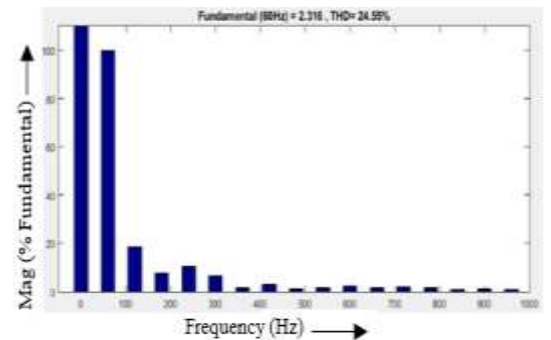

Figure 13. Electromagnetic torque of zeta fed BLDC

Table 4. Comparative study on converters

Name of Converters	Output Voltage (Volt)	Output Current (mA)	Stator Current	THD (%) of			(Efficiency $y=\eta$)(%)
				Output Voltage	Back EMF	Electromagnetic Torque	
ZETA	37.25	745	18.14	15.47	33.19	24.55	86.25
SEPIC	38.26	956.5	39.32	25.37	37.45	37.83	75.3
FLYBACK	12.71	57.79	46.85	51.44	47.57	46.46	36.45

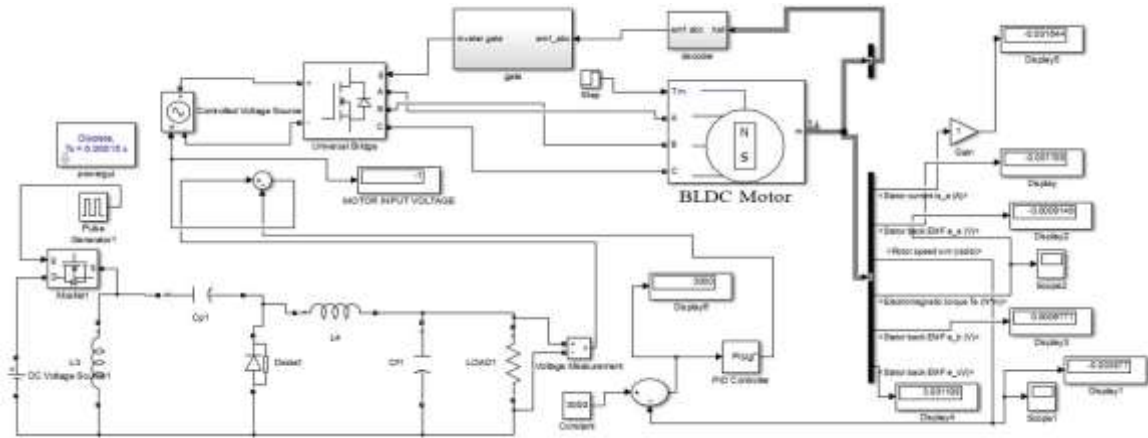

Figure 14. Zeta fed BLDC motor with PID controller

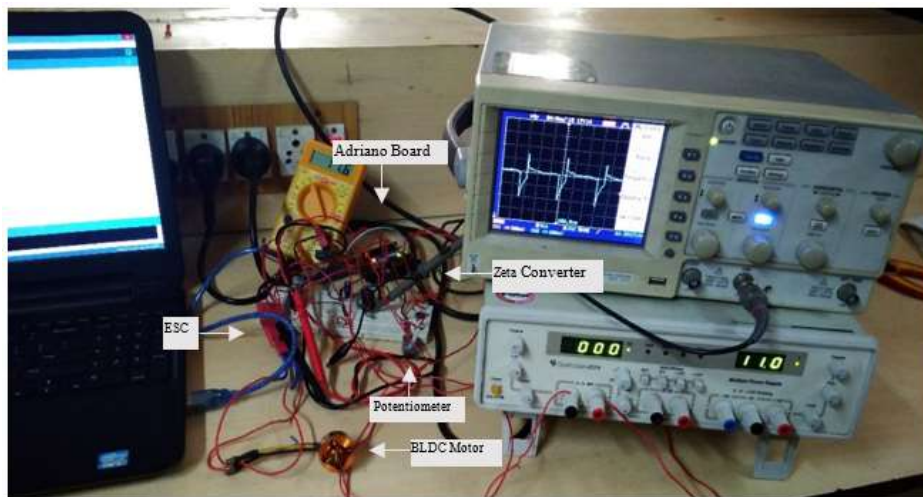

Figure 15. Hardware setup of zeta converter fed BLDC

Table 5. Parameters

BLDC MOTOR	Pole Pairs	4
	Stator Phase Resistance(Ω)	0.0485
	Inertia(kg.m ²)	0.0027
SEPIC Converter(Boost Mode)	Inductors(L_1, L_2)	$L_1= 150\mu\text{H}; L_2= 150\mu\text{H}$
	Capacitors(C_1, C_2)	$C_1= 100\mu\text{F}; C_2=100\mu\text{F}$
	Load Resistance(R_L)	$R_L= 10\Omega$
	Duty Cycle(D)	$D = 0.65$
Zeta Converter(Boost Mode)	Inductors(L_1, L_2)	$L_1=100 ; L_2= 150\mu\text{H}$
	Capacitors(C_1, C_2)	$C_1=C_2=100\mu\text{F}$
	Load Resistance(R_L)	$R_L= 10\Omega$
	Duty Cycle(D)	$D = 0.65$
Flyback Converter(Boost Mode)	Inductors(Primary= L_1 ;Secondary= L_2)	$L_1= 0.4585\text{H}; L_2= 0.0842\text{H}$
	Capacitor(C_0)	$C_0=60\mu\text{F}$
	Load Resistance(R_L)	$R_L= 220\Omega$
	Duty Cycle(D)	$D = 0.65$

4. CONCLUSION

A comprehensive study of three different configurations of converters has been presented and simulated results have been studied. We have fed the three converters output to the BLDC input and it observed that the total harmonic distortion of Zeta converter is less in all cases such as back EMF, electromagnetic torque, stator Current, output voltage. Flyback converter is more than the SEPIC and Zeta converter. The Efficiency for Zeta converter much higher than SEPIC and Flyback converter. Back EMF, stator current and electromagnetic torque of Converter is more than that of other two converters. So we have implemented Zeta Converter in hardware and we have fed the output of it to the BLDC motor. We have also implemented the SEPIC converter in hardware as we have more output voltage in the converter.

REFERENCES

- [1] V. Bist and B. Singh, "An Adjustable Speed PFC Bridgeless Buck-Boost Converter Fed BLDC Motor Drive", *IEEE Transactions on Industrial Electronics*, 2014.
- [2] S. Mondal, A. Majumder, D. Chowdhury, M. Chattopadhyay, "An efficient power delivering scheme for sensorless drive of Brushless DC motor", *Springer journal, Microsystem Technologies*, 2018.
- [3] J. Fang, H. Li, and B. Han, "Torque ripple reduction in BLDC torque motor with nonideal back EMF," *IEEE Transactions on Power Electronics*, vol 27(11), 4630–4637.
- [4] S. Mondal, A. Nandi, I. Mallick, C. Ghosh, Al. Giri, "Performance evaluation of brushless DC motor drive for three different types of MOSFET based DC-DC converters", *IEEE International Conference, DevIC2017*.
- [5] K. Habib, A. Alam, S. Khan, R. Amin, "Average Current Control Mode Boost Converter for the Tuning of Total Harmonic Distortion & Power Factor Correction Using PSIM", In: *Journal of Electrical Engineering*.
- [6] S. Munisekhar, G.V. Marutheswar, P. Sujatha, K.R. Vadivelu, "A novel approach for the fastest MPPT tracking algorithm for a PV array fed BLDC motor driven air conditioning system," *Indonesian Journal of Electrical Engineering and Computer Science*, Vol. 18, No. 2, May 2020, pp. 622~628.
- [7] S. Mondal, A. Mitra and M. Chattopadhyay, "Mathematical modeling and Simulation of Brushless DC motor with Ideal Back EMF for a Precision speed control", *IEEE International Conference (ICECCT-2015)*.
- [8] C. Zhang, D. Bian, "APWM Control Algorithm for Eliminating Torque Ripple Caused by Stator Magnetic Field Jump of Brushless DC Motors", *Proceedings of the 7th World Congress on Intelligent Control and Automation*, 2008, China.
- [9] S. Mondal, A. Mitra, D. Chowdhury, M. Chattopadhyay, "A New Approach of Sensorless Control Methodology for Achieving Ideal Characteristics of Brushless DC Motor Using MATLAB/Simulink", *C3IT, IEEE* 2015.
- [10] G. G. Raja Sekhar, Basavaraja Banakar, "Solar PV fed non-isolated DC-DC converter for BLDC motor drive with speed control", *Indonesian Journal of Electrical Engineering and Computer Science*, Vol. 13, No. 1, January 2019.
- [11] S. Jung, Y. Kim, J. Jae & J. Kim, "Commutation Control for the Low-Commutation Torque Ripple in the Position Sensorless Drive of the Low-Voltage Brushless DC Motor", *IEEE Transactions on Power Electronics*, vol 29 (11), 2014.
- [12] T. Shi, Y. Guo, P. Song & C. Xia, "A New Approach of Minimizing Commutation Torque Ripple for Brushless DC Motor Based on DC-DC Converter", *IEEE Transactions on Industrial Electronics*, vol 57 (10), 2010.
- [13] D. S. Nayak, R. Shivarudraswamy, "Solar fed BLDC motor drive for mixer grinder using a boost converter", *International Journal of Power Electronics and Drive System*, vol 11(1), 56-63.
- [14] Murugan M, Jeyabharath R, Sarankumar V, "An Approach of PFC in BLDC Motor Drives Using BLSEPIC Converter", *Indonesian Journal of Electrical Engineering*, vol 14(2), 215-221.
- [15] H.S. Chung, K.K. Tse, S.Y. Ron Hui, C.M. Mok, M.T. Ho, "A novel maximum power point tracking technique for solar panels using a SEPIC or Cuk converter", *IEEE Transactions on Power Electronics*, vol 18(3), May 2003.
- [16] V. Bist and B. Singh, "A Brushless DC Motor Drive with Power Factor Correction using Isolated-Zeta Converter," *IEEE Transactions on Industry Applications*, vol.10, no.4, pp.2064-2072, Nov. 2014.
- [17] H. Zhang, Y. Zhang, and X. Ma, "Distortion Behavior Analysis of General pulse-width Modulated Zeta PFC converter operating in continuous conduction mode", *IEEE trans. On power electronics*, vol.27, No.10, Oct 2012.
- [18] P. Ramesh Babu, S. Ram Prasath and R. Kiruthika, "Simulation and Performance Analysis of CCM Zeta Converter with PID Controller", *International Conference on Circuit, Power and Computing Technologies [ICCPCT]*, 2015.
- [19] V. Bist and B. Singh, "A reduced sensor PFC BL-Zeta converter based VSI fed BLDC motor drive", *Electric Power Systems Research, Elsevier*, 2013.
- [20] A. Priya and Sasilatha, "Performance Development of a BLDC Motor Driven Water Pump using KY Converter", *Indonesian Journal of Electrical Engineering and Computer Science*, vol 9 (3), 602-605.
- [21] R. Balamurugan, J. Pearly Catherine, "An Approach of Power Factor Correction in BLDC Motor Drives Using Cuk Derived Converters", *Indonesian Journal of Electrical Engineering*, vol 12(12), 8092-8097.
- [22] V. Bist & B. Singh, PFC Cuk Converter-Fed BLDC Motor Drive, *IEEE Transactions on Power Electronics*, 30 (2), 2015.
- [23] G. M. Ponzio, G. Capponi, P. Scalia & V. Boscaino, "An improved Flyback converter", 2009 6th International Conference on Electrical Engineering/Electronics, Computer, Telecommunications and Information Technology.
- [24] A. Mohammed & S. Nafie, "Flyback converter design for low power application", 2015 International Conference on Computing, Control, Networking, Electronics and Embedded Systems Engineering (ICCNTEE).
- [25] U. Boeke. "High Efficiency Flyback Converter Technology". *Power Conversion Conference - Nagoya*, DOI:10.1109/PCCON.2007.373128. 2007.