

## Transmission Performance Research of Digital Modulation Signals in AWGN Channel

Jianbin Xue<sup>\*a</sup>, Songbai Li<sup>b</sup>

School of Computer and Communication, Lanzhou University of Technology, Lanzhou, 730050, China

<sup>\*</sup>Corresponding author, e-mail: <sup>a</sup>xue\_jabn@hotmail.com, <sup>b</sup>rackby@163.com

### Abstract

As mainstream of wireless communication system, digital communication system cannot directly transmit digital baseband signals that must be modulated at the sender before being sent into wireless channel. Digital modulation that is using baseband signals to control the parameters of carrier, includes amplitude modulation, frequency modulation and phase modulation. Noise existing in wireless channel can seriously affect signal's transmission performance. AWGN (additive white Gaussian noise) channel is the most simple radio channel, this paper aims at transmission performance analysis of three kinds of digital modulation signals in AWGN channel and comparing the simulation value with theoretical value that's not affected by AWGN, the idea proposed in this paper includes four ways that cover the comparison between simulated BER (bit error rate) and theoretical BER, simulated SER (symbol error rate) and theoretical SER, the simulation results show the difference about transmission performance of modulated signals with or without AWGN.

**Key words:** AWGN, carrier modulation, bit error rate, symbol error rate

Copyright © 2013 Universitas Ahmad Dahlan. All rights reserved.

### 1. Introduction

During the 1980s, the emergence of digital communication based on digital technologies promoted the second generation of mobile communication system and its standardization development, the application of digital technologies not only increased system capacity, but also made wireless business quality more reliable, the basic technology of digital communication is digital signal generation and transmission. Digital modulation is using discrete values characteristics to control carrier's parameters, which includes amplitude modulation, phase modulation and frequency modulation, the emergence of a variety of modulation technologies have a far-reaching influence on the development of wireless communication, some modern improved modulations, such as QAM, MSK and DPSK are developed from the most basic binary modulation. Wireless channel is a very important part in wireless communication system, and wireless channel transmission quality can affect signal receiving and demodulation. AWGN is a very simple and common noise in wireless channel, its mean value is zero, its variance is the noise power size, AWGN can make modulated signals fluctuate randomly around the signals average value, the greater the AWGN power is, the bigger the fluctuation range will be, and its BER and SER at receiving end will be higher, so, it is very necessary to study signal transmission performance in AWGN channel before the research about BER or SER and wireless channel quality.

Literature [1] only has a research on transmission performance of binary frequency modulation in Gaussian channel and Rayleigh channel, it does not have a comparison analysis of different digital modulation ways; literature [2] and [3] mainly focus on digital signal circuit design and verifying the test results of carrier modulation and demodulation; literature [4], to obtain the best demodulation performance of EBPSK system in AWGN channel, derives BER formula under sampling judgment and integral judgment, and compares the difference between practical BER and theory BER by simulation; literature [5] has a research on amplitude and SNR (signal-to-noise ratio) of PSK (phase shift keying) signal transmission in AWGN channel, and analyzes SNR estimation algorithm performance, etc. All of the above articles only have a research on one digital signal modulation way or the performance on one aspect of digital modulation signal, this paper at first mathematically analyzes three digital modulation signals production, then constructs the system model and uses matlab simulation modules and codes

to simulate the model, at last, synthetically analyzes the three kinds of digital modulation signals' transmission performance in AWGN channel and compares the differences between simulation value and theoretical value.

## 2. Mathematical Analysis

### 2.1.1. Amplitude Modulation Signal Production

Suppose:

$$s_n(t) = A_n g(t) \quad (1)$$

here,  $A_n$  is  $n$ th wave amplitude and has discrete values,  $g(t)$  is a certain pulse whose shape determines transmitting signal's frequency spectrum characteristics,  $G(f)$  is the Fourier transformation of  $g(t)$ . Assume the baseband signal frequency spectrum is  $|f| \leq W$ ,  $W$  is the bandwidth of  $|G(f)|^2$ , when baseband signal multiplies carrier, then the transmitting signal is:

$$s(t) = A_n g(t) \cos(2\pi f_c t) \quad (2)$$

when transmission pulse shape of  $g(t)$  is rectangular:

$$g(t) = \sqrt{2/T} \quad (3)$$

here,  $0 \leq t \leq T$ , the modulated signal spectrum is:

$$S(f) = \frac{A_n}{2} [G(f + f_c) + G(f - f_c)] \quad (4)$$

baseband signal spectrum is flitted to carrier  $f_c$ , which does not change the basic geometric representation of digital amplitude signal wave, generally, AM signals can be presented as:

$$s(t) = s_n \phi(t) \quad (5)$$

here,  $\phi(t)$  is defined as:

$$\phi(t) = g(t) \cos(2\pi f_c t) \quad (6)$$

and  $s_n = A_n$ , which represents signal constellation points when taking  $N$  values on solid line.

### 2.1.2. Demodulation

Such AM signals can be demodulated by correlation filters, if the received signal is:

$$r(t) = A_n g(t) \cos(2\pi f_c t) + n(t) \quad (7)$$

here,  $n(t)$  is noise that can be presented as:

$$n(t) = n_c(t) \cos(2\pi f_c t) - n_s(t) \sin(2\pi f_c t) \quad (8)$$

here,  $n_c(t)$  and  $n_s(t)$  are in-phase component and quadrature component, through doing cross-correlation, the output signals put into detector can be presented as (9):

$$\int_{-\infty}^{+\infty} r(t) \phi(t) dt = A_n + n = s_n + n \quad (9)$$

here,  $n$  is noise component from correlation filter, its mean value is 0, variance is:

$$\sigma_n^2 = \int_{-\infty}^{+\infty} |\Phi(f)|^2 S_n(f) df \quad (10)$$

$\Phi(f)$  is the Fourier transformation of  $\phi(t)$ ,  $S_n(f)$  is AWGN power spectral density, so the variance can be presented as  $N_0/2$ , the error probability  $P_N$  is:

$$P_N = \frac{2(N-1)}{N} Q(\sqrt{6E_s/(N^2-1)N_0}) \quad (11)$$

### 2.2.1. Phase Modulation Signal Production

$M$  phase modulation signal waves can be expressed as:

$$x_m(t) = f(t) \cos(2\pi f_c t + \frac{2\pi m}{M}) \quad (12)$$

here,  $m=0,1,\dots,M-1, 0 \leq t \leq T$ ,  $f(t)$  is signal pulse shape,  $\theta_m=2\pi m/M$  is  $M$  possible phases that can be used to transfer information, signal waves have equal energy  $E_x$  that is presented as:

$$E = \int_0^T x_m^2(t) dt = \frac{1}{2} \int_0^T f^2(t) dt = \frac{1}{2} E_f = E_x \quad (13)$$

here,  $E_x$  represents each transmission symbol energy, when  $f(t)$  is a rectangular pulse:

$$x_m(t) = \sqrt{2/T} \cos(2\pi f_c t + 2\pi m/M) = x_{m1}\phi_1(t) + x_{m2}\phi_2(t) \quad (14)$$

here,  $m=0,1,\dots,M-1, 0 \leq t \leq T$ ,  $\phi_1(t)$  and  $\phi_2(t)$  are two orthonormal signals.

### 2.2.2. Phase signal demodulation

In AWGN channel, the received signal is:

$$r(t) = x_m(t) + n(t) = x_m(t) + n_c(t) \cos(2\pi f_c t) - n_s(t) \sin(2\pi f_c t) \quad (15)$$

here,  $n_c(t)$  and  $n_s(t)$  are two orthogonal components of AWGN, the output signals can be affected by AWGN, which is shown as:

$$r = x_m + n = (\cos 2\pi m/M + n_c, \sin 2\pi m/M + n_s) \quad (16)$$

here,  $n_c$  and  $n_s$  are defined as:

$$n_c = \frac{1}{2} \int_0^T f(t) n_c(t) dt \quad (17)$$

$$n_s = \frac{1}{2} \int_0^T f(t) n_s(t) dt$$

here,  $n_c(t)$  and  $n_s(t)$  are unrelated Gaussian random processes, and have the same mean value 0 and variance  $N_0/2$ . The error probability  $P_M$  is:

$$P_M \approx 2Q(\sqrt{2E_x/N_0} \sin \frac{\pi}{M}) \quad (18)$$

### 2.3.1. Frequency Modulation Signal Production

If  $K$  orthogonal signals with the same energy and different frequency are as follows:

$$s_k(t) = \sqrt{2E/T} \cos(2\pi f_c t + 2\pi k \Delta f t) \quad (19)$$

and low pass equivalent signal is:

$$s_{lk}(t) = \sqrt{2E/T} e^{j2\pi k \Delta f t} \quad (20)$$

here,  $k=0,1,\dots,K-1, 0 \leq t \leq T$ ,  $E$  is each symbol's energy, and  $\Delta f$  is frequency interval between two successive frequencies, which means:

$$\Delta f = f_k - f_{k-1} \quad (21)$$

and:

$$f_k = f_c + k\Delta f \tag{22}$$

these waves have the same energy and cross correlation coefficient shown as:

$$\rho_{kx} = \frac{1}{E} \int_0^T s_x(t)s_k(t)dt = \frac{\sin[2\pi(x-k)\Delta fT]}{2\pi(x-k)\Delta fT} \tag{23}$$

These signals are orthogonal when  $\Delta f$  is integer times of  $1/(2T)$ , and the minimum frequency interval between two successive frequencies is  $1/(2T)$ .

When  $\Delta f = 1/(2T)$ , FSK (frequency shift keying) signals are equal to  $K$  dimensions vector:

$$\begin{aligned} s_0 &= (\sqrt{E}, 0, \dots, 0) \\ s_1 &= (0, \sqrt{E}, 0, \dots, 0) \\ &\vdots \\ s_k &= (0, \dots, 0, \sqrt{E}) \end{aligned} \tag{24}$$

the basis function is:  $\phi_k(t) = \sqrt{2/T} \cos(2\pi(f_c + k\Delta f)t)$  (25)

**2.3.2. Frequency signal demodulation**

Suppose frequency modulation signals are transmitted through AWGN channel and every signal is delayed in wireless channel, then, the signals put into demodulator can be presented as:  $r(t) = \sqrt{E/T} \cos(2\pi f_c t + 2\pi k\Delta f t + \theta_k) + n(t)$  (26)

here,  $\theta_k$  is the  $m$ th phase shift because of transmission delay,  $n(t)$  is noise presented as:

$$n(t) = n_c(t) \cos(2\pi f_c t) - n_s(t) \sin(2\pi f_c t) \dots \tag{27}$$

Usually, the demodulation method of frequency modulation signal is non-coherent demodulation, the block diagram is shown as Figure 1:

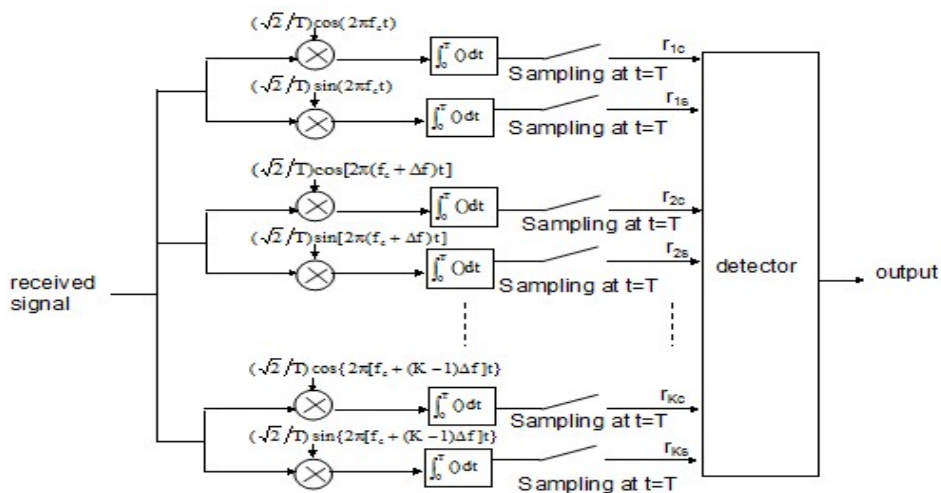

Figure 1. KFSK Signal Demodulation

Figure 1 shows that every signal has two correlators, so, there are  $2K$  correlators in all, signal and basis functions  $\Phi_{kc}(t)$  and  $\Phi_{ks}(t)$  can be related, the output signals from  $2K$  correlators are sampled and transmitted into detector, if transmitting the  $y$ th signal, then  $2Y$  samples put in detector can be presented as:

$$r_{yc} = \sqrt{E} \left[ \frac{\sin(2\pi(k-y)\Delta fT)}{2\pi(k-y)\Delta fT} \cos \theta_y - \frac{\cos(2\pi(k-y)\Delta fT)}{2\pi(k-y)\Delta fT} \sin \theta_y \right] + n_{yc}$$

$$r_{ys} = \sqrt{E} \left[ \frac{\cos(2\pi(k-y)\Delta fT)}{2\pi(k-y)\Delta fT} \cos \theta_y - \frac{\sin(2\pi(k-y)\Delta fT)}{2\pi(k-y)\Delta fT} \sin \theta_y \right] + n_{ys}$$
(28)

here,  $n_{yc}$  and  $n_{ys}$  represent Gaussian noise from sampling output, if  $y=k$ , then, the sampled values are:

$$r_{kc} = \sqrt{E} \cos \theta_k + n_{kc}$$

$$r_{ks} = \sqrt{E} \sin \theta_k + n_{ks}$$
(29)

If  $y \neq k$ , the signal component from sample  $r_{yc}$  and sample  $r_{ys}$  is 0, so, the symbol error probability is:

$$P_k = \sum_{i=1}^{K-1} (-1)^{i+1} \binom{K-1}{i} \frac{1}{i+1} e^{-\frac{1}{i+1} \frac{E}{N_0}}$$
(30)

and bit error probability  $P_b$  is:

$$P_b = \frac{K}{2(K-1)} P_k$$
(31)

### 3. Results and Discussion

#### 3.1. AWGN Mathematical Model

Noise itself is a random process and can badly affect wireless channel's transmission performance, it's very difficult to predict noise signal's strength at a certain moment through a simple calculation method. AWGN is a kind of very simple and common noise when compared with other noises, for  $n$  dimensions random variables  $X$ , if its mean value is  $\mu$ , collaborative variance matrix is  $K$ , then, the probability for  $X=x$  is:

$$p(x) = \exp\left(-\frac{(x-\mu)^T K^{-1} (x-\mu)}{2}\right) / \sqrt{(2\pi)^n \det K}$$
(32)

here,  $T$  means transposition,  $X=(X_1, X_2, \dots, X_n)$ , and  $\mu=(\mu_1, \mu_2, \dots, \mu_n)$ ,  $\det K$  represents the determinant value of collaborative variance matrix  $K$ .

#### 3.2. Simulation System Construction

The system structure about the idea proposed in this paper is simulated by matlab simulink modules and codes, constructed as Figure 2.

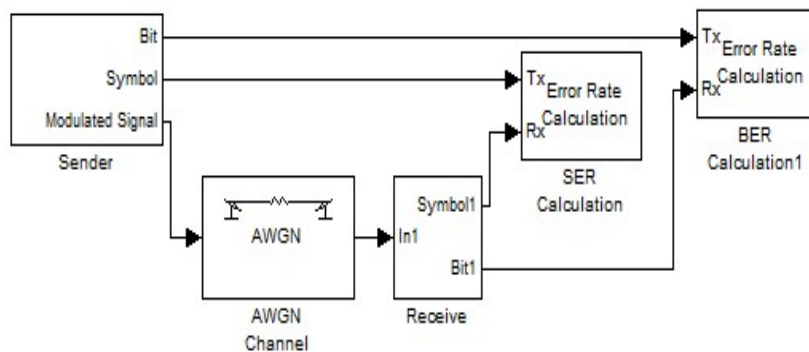

Figure 2. Transmission System Model

#### 3.3. Transmission Process

Simulation system includes:

- (1) Sender: data generated in sub-module random integer generator and including

amplitude modulation signal, phase modulation signal and frequency modulation signal are divided into four different source outputs and transmitted into four channels: channel A only has bit error module, data transmitted through channel A is not affected by noise, which means the result from channel A is theoretical BER; channel B has AWGN and bit error module, the result from channel B is AWGN affected BER; channel C only has symbol error module, the result from channel C is theoretical SER; channel D has AWGN and symbol error module, then the result from channel D is AWGN affected SER. So we can get the comparison results that show the difference among channel A, B, C, D of the three kinds digital modulations.

(2). Wireless channels: one is theoretical channel that has no noise, the other has AWGN generator, which generates AWGN and put it into modulated signals.

(3). Destination: the receiver subsystem receives signals from four ways, the first two ways have AWGN, data after being demodulated by the baseband demodulator go through symbol error calculator and bit error calculator, then we get the results of AWGN affected SER and BER, the other two ways that have no AWGN go directly through symbol error calculator and bit error calculator, then we get results that has no influence of AWGN.

### 3.4. Simulation Results Analysis

Simulation parameters are: the number of symbols under each SNR is 100000, symbol period is 1s, sampling points of each symbol are 100, carrier frequency is 10Hz etc. Simulation results are shown as Figure 3 to Figure 8.

Figure 3 shows the result of amplitude modulation, with SNR growing, both of SER and BER are becoming better, but the change of BER is not as obvious as SER, and SER betters more quickly, what's more, theoretical value is better than simulated value which is affected by AWGN, but the variation trend is almost the same. Figure 3 tells that amplitude modulation signals have a better anti-interference performance on SER.

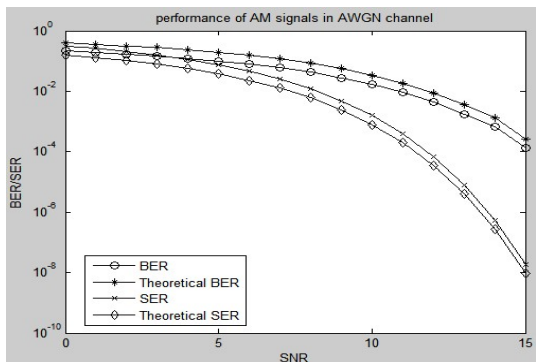

Figure 3. Transmission Performance of AM

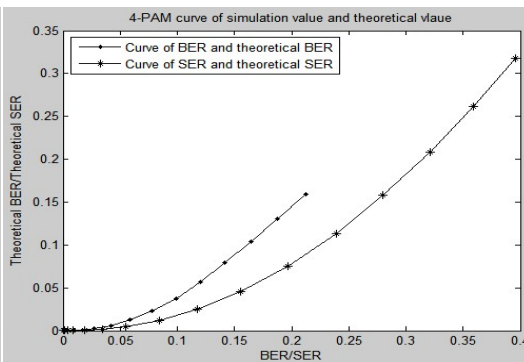

Figure 6. 4-PAM Simulation Result

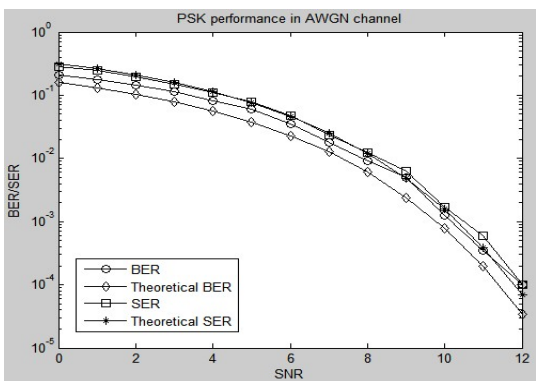

Figure 4. Transmission Performance of PSK

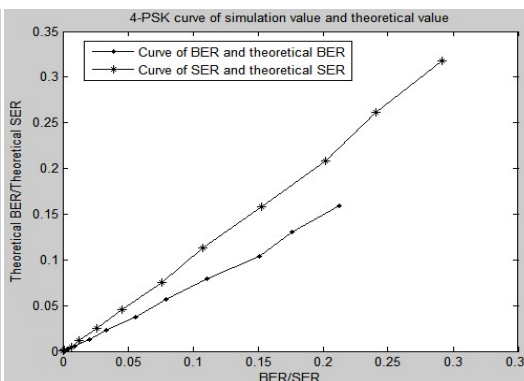

Figure 7. 4-PSK Simulation Result

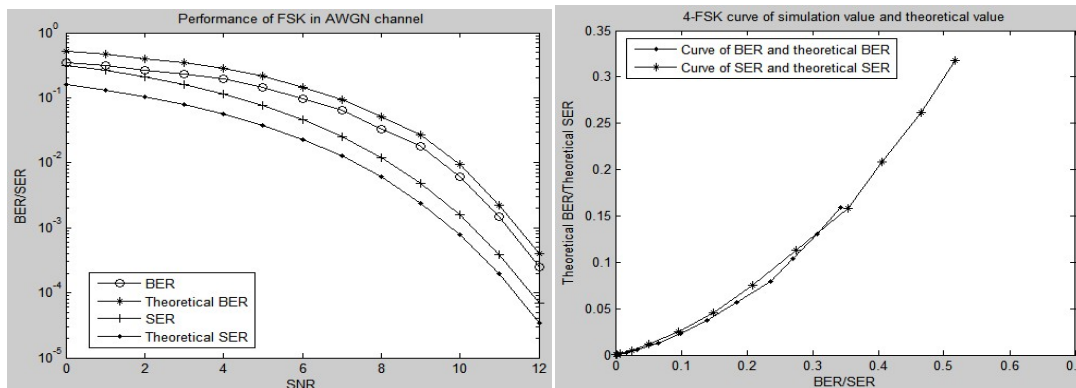

Figure 5. Transmission Performance of 4-FSK

Figure 8. 4-FSK Simulation Result

#### 4. Conclusion

From the above analysis we know that digital modulation signals generally have a good transmission performance in AWGN channel, which means that such signals have a good anti-noise property; the properties of such three kinds of digital modulation signals can be suitable for different situations, that's why such three have been widely used. For example, the highest order of HSPA downlink has been increased to 64QAM, and EV-DO Rev C technology takes QPSK, 8PSK and 64QAM as its downlink main modulation modes, etc, from where we can see that digital modulation not only has a good transmission performance in AWGN channel, but also in other more complicated wireless channels too, digital modulation signal is promising in modern wireless communication system.

#### References

- [1] Qingquan Zhang, Xiaoshuai Xing, etc. Transmission performance simulation analysis of BF- SK signals in Gaussian and Rayleigh channel. *Journal of Shanxi normal university*. 2010; 24(1): 64-66.
- [2] Deqiang Huang. Design and verification of baseband signal digital modulation. *Journal of Electronic device*. 2009; 32(4): 812-816.
- [3] Fenghua Wang, Liyong Zhang, etc. Digital modulation signal transmitter design. *Journal of Harbin university of science and technology*. 2003; 8(6): 38-40.
- [4] Changhong, Jiajia Ding, etc. EBPSK system demodulating performance analysis in AWGN channel. *Journal of southeast university*. 2012; 42(1): 14-19.
- [5] Shenfu Pan, Zhendong Li. etc. PSK signal amplitude and SNR estimation in AWGN channel. *Communication journal*. 2004; 25(3): 167-172.
- [6] Denghua. Communication Simulation and Application Examples Explanation of MATLAB. Beijing: PTRSS. 2003: 78-80.
- [7] John G Proakis, Masoud Salehi. *Contemporary Communication System Using Matlab*. Beijing: Science Press. 2001: 291-310.
- [8] Roakis JG. Digital communication. 4<sup>th</sup> ed. NewYork: McGraw-Hill. 2002: 169-176.
- [9] Ali M Fadhil, Haider M AISabbagh. Performance Analysis for Bit-Error-Rate of DS-CDMA Sensor Network Systems with Source Coding. *TELKOMNIKA Indonesian Journal of Electrical Engineering*. 2012; 10(1): 165-170.
- [10] CF Cai, Y Zhang, JY Ren, LY Jiang. Computation of the Normalized Prediction Error of the Electroencephalogram Signal. *TELKOMNIKA Indonesian Journal of Electrical Engineering*. 2012; 10(5): 1021-1026.