

Investigation of monthly variations in the efficiencies of photovoltaics due to sunrise and sunset times

Armstrong O. Njok¹, Julie C. Ogbulezie², Manoj Kumar Panjwani³, Raja Masood Larik⁴

¹Department of Physics, Faculty of Physical Sciences, Cross River University of Technology (CRUTECH) Calabar, Nigeria

²Department of Physics, Faculty of Physical Sciences, University of Calabar, Nigeria

³Department of Energy Systems Engineering, Sukkur IBA University, Pakistan

³Renewable Energy School, North China Electric Power University Beijing, China

⁴School of Electrical Engineering, Universiti Teknologi Malaysia Skudai, Malaysia

Article Info

Article history:

Received Apr 23, 2019

Revised Jul 14, 2019

Accepted Jul 21, 2019

Keywords:

Ambient temperature

Panel temperature

Peak efficiency

Relative humidity

Sunrise and sunset times

ABSTRACT

The effect of time of day and month on the efficient conversion of solar energy to electrical energy using a polycrystalline (PV) module in Calabar was studied. A KT-908 precision digital hygrometer and thermometer, and a M890C+ digital multimeter were used in the process. Results obtained show that photovoltaic produce different levels of peak efficiencies at different times of the day for different months due to the difference in sunrise and sunset times for the months. The results also indicated that photovoltaics will be more efficient in months with low average relative humidity couple with low panel temperature. A peak efficiency of 77% at 12:30 in the month of April was observed before dropping to 73% at 12:00 in the month of May, indicating that there might be further drop in efficiency as we proceed further into the year. Results also show that photovoltaics are more efficient before noon in the month of May than in April while the reverse will be observed in the afternoon.

Copyright © 2020 Institute of Advanced Engineering and Science.
All rights reserved.

Corresponding Author:

Armstrong O. Njok,
Department of Physics, Faculty Physical of Sciences,
Cross River University of Technology (CRUTECH) Calabar,
Calabar, 540252, Nigeria.
Email: njokarmstrong@crutech.edu.ng

1. INTRODUCTION

Solar energy is the radiant heat and light from the sun that has been used by humans since ancient times using a wide range of technologies. Even though the sun ranks as a run-of-the-mill star, it releases a huge quantity of energy in terms of human capacity or need. Power output per second is 3.86×10^{20} megawatts (MW), several billion times the electric capacity of Nigeria's power producing utilities. This energy fills the solar system, bathing the earth's atmosphere with a near constant supply of 1.37 kilowatts per square meter (kW/m^2) [1]. Not all the direct sunlight incident on earth's atmosphere arrives at the earth's surface. The atmosphere attenuates many parts of the spectrum; the level of attenuation may vary by geographical location on the surface of the earth. For example, X-rays are almost totally absorbed before reaching the ground. A good percentage of ultraviolet radiations are also filtered out by the atmosphere. Some radiations are reflected back into space. Some are randomly scattered by the atmosphere, which makes the sky look blue.

Solar energy is a renewable source of energy and it is among the fastest growing energy resource in the world, which is clean, noiseless, pollution free and offers many benefits to human. Solar energy is receiving immense attention because renewable energy is on tremendous focus due to the depletion of the ozone layer and global warming. Due to increasing cost of fossil fuel couple with the fact that Nigeria has a

low wind potential for electricity generation, it is important to investigate the potential of electricity generation through solar energy. In many rural locations of Nigeria, solar energy could provide a cost effective and unique way out of electrification failure for both metropolitan and rural areas. These are areas where high level of economic and agricultural activities takes place without access to electricity and water supply.

The unsustainability of the present production-consumption energy model highlights the finite nature of conventional energy sources. The environmental degradation occasioned by the emission currently generated by the use of fossil fuels causes serious environmental problems, such as acid rain, greenhouse effect and ozone layer depletion, which in many cases are irreversible [2]. Technological dependency of the industrialized world on fossil fuels and how these fuels have steadily degraded the earth's environment is quite alarming. In our generation, our climate is receiving unprecedented attention because, human activity on earth during the past couple of hundred years have led to significantly large and rapid changes in environmental conditions [3]. These changes affect health, comfort levels, and ability to grow and distribute food [4]. Recently, humans are seeking and exploring renewable energy for fossil fuels to be replaced. This exploration is triggered by the extinction of fossil fuel beneath the earth surface, prompting humans not to depend on it forever. Solar energy is one of the most potential renewable energy sources [5].

Ozbay et al. [6] monitored the monthly, seasonal and yearly optimum tilt angles by raspberry pi card for Bilecik city, Turkey. It was discovered that the panel with 10° tilt angle produced more power compared to the other panels for the months of June, July and August while the panel with 60° tilt angle produced less power, leading to the conclusion that the best tilt angle for summer season is found to 10° and the worst tilt angle found to be 60° .

Huld et al. [7] investigated the geographical variation of the conversion efficiency of crystalline silicon photovoltaic modules in Europe. From their results it was found that the geographical variation in ambient temperature and yearly irradiation causes a decrease in overall yearly PV performance from 3 to 13% relative to the performance under Standard Test Conditions, with the highest decrease found in the Mediterranean region.

Gaur et al. [8] researched the performance of photovoltaic modules of different solar cells. The analysis was carried out particularly for the climatic conditions in the months of January and June in New Delhi, India. They concluded that for all the PV module technologies, the efficiency first decreases and then increases with time from morning to evening in both months of January and June.

Omubo-pepple et al. [9] using a B-K Precision module 615 digital light instrument and PV modules in Port Harcourt researched on the effect of solar flux and relative humidity on the efficient conversion of solar energy to electricity. Results obtained shows that current increases when relative humidity drops, which means low water vapor in the atmosphere, resulting to high flux which enhances high current production.

Ettah et al. [10] carried out an investigation in Calabar (Nigeria) about the effect of relative humidity on the performance of solar panels. Their results demonstrate that low relative humidity between 69% and 75% favors an increase in output current from solar panels, with voltage stabilizing between relative humidity values of 70% and 75%, as well increases with a decrease in relative humidity.

Ike [11] investigated the effect of temperature on the performance of a photovoltaic solar system in eastern Nigeria. The results show that there is an indirect proportionality between the power output produced by the system and the ambient temperature of the locality. Thus the application of photovoltaic technology in the conversion of solar energy to electricity is not favorable during the period of very high ambient temperature than the period of low ambient temperature. The results indicated that PV solar panels must be installed at a place where they receive more air current so that the temperature remains low while the power output remains high.

Hirata et al. [12] investigated how seasonal changes in cell temperature and spectral solar radiation affect the seasonal variation in photovoltaic (PV) module conversion efficiency for CdS–CdTe and two-layer tandem-amorphous silicon. Results obtained shows that The CdS conversion efficiency increased during summer by 7%, although the spectral ratio available to CdS increases, the conversion efficiency does not increase by the same amount, because of an increase in cell temperature.

Muhammad et al. [13] compared the performance of photovoltaic modules during winter months in Taxila, Pakistan. The study concluded that output power of modules increases linearly with increase of solar irradiance. The c-Si module shows high average output power, but a-Si shows higher normalized output power efficiency due to its better performance in low irradiance condition. The overall average module efficiency of c-Si module was 13.01%, which is higher than the average module efficiency of the other two modules. Results depict that module efficiency shows a decreasing trend with increase of solar irradiance and module temperature. The average module efficiency decreased by about 8.85%, 4.5% and 26% for c-Si, p-Si and a-Si modules respectively, with increase in module temperature from 22 to 33°C.

Mansur et al. [14] studied the performance analysis of self-consumed solar PV system for a fully DC residential house and realized temperature effect to the PV module contributed to the system losses, as well as batteries and converter efficiencies.

Verayah & Iyadurai [15] carried out a comparison study on types of PV for grid connected photovoltaic power and found that the monthly output energy of solar modules are influenced by ambient temperature and solar irradiance.

Syafiqah et al. [16] reported that the increase in the operating temperature directly leads to the reduction of output power from Photovoltaic Panels.

Adinoyi & Said [17] researched on the effect of dust accumulation on the power outputs of solar photovoltaic modules in the eastern province of Saudi Arabia and unravel that those PV modules that are left with dirt on their surface for duration of six months and above can have its power decrease by as much as 50%.

Leow et al. [18] investigated the performance difference of PV panels subjected to different wind velocity. The results encourage photovoltaic panels to be exposed and operated in the open atmosphere with considerable wind velocity for achieving better output power.

Mejia et al. [19] studied the effect of dust on solar photovoltaic systems in Santa Clara and found that it is during the long dry summer that soiling losses have their highest impact.

Khanna et al. [20] studied the effect of climate on electrical performance of finned phase change material integrated solar photovoltaic and discovered that under clear sky, finned phase change material is more beneficial. More heat is produced and thus requires external cooling due to large incidence of solar flux.

Armelia et al. [21] investigated the effect of temperature on photovoltaic (PV) panel output performance through software simulation and outdoor experiments and showed that a crucial role is played by panel temperature during power production.

Mustapha et al. [22] reported that there is a direct proportionality between temperature, solar power and the power produced by the photovoltaic module after carrying out a performance evaluation of polycrystalline solar photovoltaic module in weather conditions of Maiduguri, Nigeria.

Amajama et al. [23] after studying the impact of wind on the output of photovoltaic panel and solar Illuminance/intensity concluded that if the sun is some distance away while the rays still hit the front of the panel and the wind is toward the front of the panel the photovoltaic output is enhanced.

This research aims to determine the monthly variation in efficiency of polycrystalline photovoltaics. The month of April and May was chosen for this research because the amount of rainfall for these months is not as high as compared to June and July. In the month of June and July it would be almost impossible to have a reasonable number of days without rainfall required for the research. Furthermore the month of January, February and March was not picked because, the difference in the sunrise and sunset times between these months is not more than eight minutes as compared to April and May that is above ten minutes.

2. STUDY AREA

Calabar, the capital of Cross River State is located in the southern part of Nigeria, located on Latitude $4^{\circ}57'06''$ N and longitude $8^{\circ}19'19''$ E at an elevation of 32m above sea level.

3. MATERIALS AND METHODS

3.1. Materials

A 130 watt polycrystalline solar panel with dimension of 1480*670*35mm and capacities of 7.18A and 18.10V at maximum current and voltage respectively. Charge controller was utilized to assure smooth charging of the lead acid battery with the specification of (12V-75AH). A digital multimeter (M890C+) was utilized to monitor voltage and current values, accompanied by a K type thermocouple for measuring temperature in Celsius. A digital thermometer (KT-908) which is equipped with a digital hygrometer and a digital alarm clock was also used which is capable of displaying temperature both in Celsius (C) and Fahrenheit (F).

3.2. Method

The solar panel was placed horizontally flat facing the sun on a platform one metre high above the ground. Connecting cables were connected to the output terminals of the solar panel. From the output terminals of the solar panel the cables were connected to a switch which led to the charge controller. The output of the charge controller was then connected to the battery for charging the battery, and from the battery the load was powered through an inverter.

Measurements were taken at an interval of 30 minutes from 6.00am to 6.00pm for 30 days (first 15 days in April and first 15 days in May) in 2017. During measurements, the voltage and the current from the panel were measured using the digital multimeter. The ambient temperature was read directly from the digital thermometer while the solar panel temperature was measured using the temperature sensing probe fixed on the solar panel. The time of day was recorded and the relative humidity measured and read directly from the digital hygrometer.

From the readings obtained the power from the solar module was determined from (1), while the normalized power output efficiency of the solar module was calculated using (2) [15]. It has also been shown by [15] that the open circuit voltage and short circuit current depend on parameters like solar irradiance and the temperature as shown in (3) and (4).

Measured Power:

$$P_{mea} = V_{mea} \times I_{mea} \tag{1}$$

Normalized power output efficiency:

$$\eta_p = \frac{P_{mea}}{P_{max}} \times 100 \tag{2}$$

Open circuit voltage:

$$V_{oc} = \frac{KT}{Q} \ln \frac{I_{sc}}{I_0} \tag{3}$$

Short circuit current:

$$I_{sc} = bH \tag{4}$$

where P_{mea} and P_{max} are the measured power and maximum power that the photovoltaic module can give out respectively. I_0 is the saturation current, Q is the electronic charge, K is the Boltzmann constant, T is the absolute temperature, H is the incident light intensity and b is a constant depending on the properties of the semiconductor junction. The block diagram of the setup is shown in Figure 1.

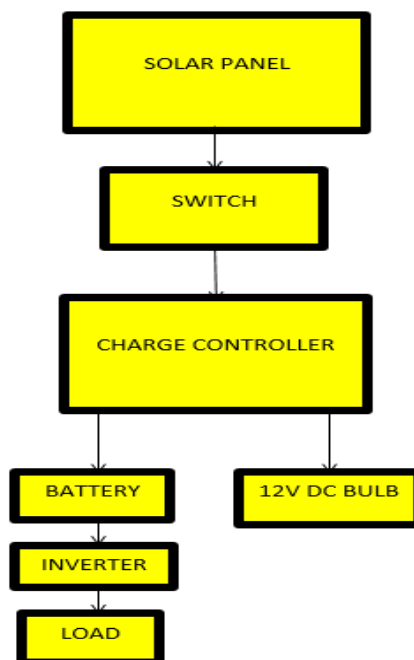

Figure 1. Block diagram of the experimental setup

4. RESULTS AND DISCUSSION

Figure 2 shows that the average relative humidity in the day before noon in the month of April is higher than that in the month of May, this is because the sun rises earlier in the month of May than in April, but the reverse is the case after noon as the chart shows a lower average relative humidity in April than in May, and this is because the sun sets earlier in the month of May. Since the sun sets late in the month of April, it provides additional sunshine to lower the relative humidity. The full daytime average relative humidity is almost the same but with that for May slightly higher than that for April.

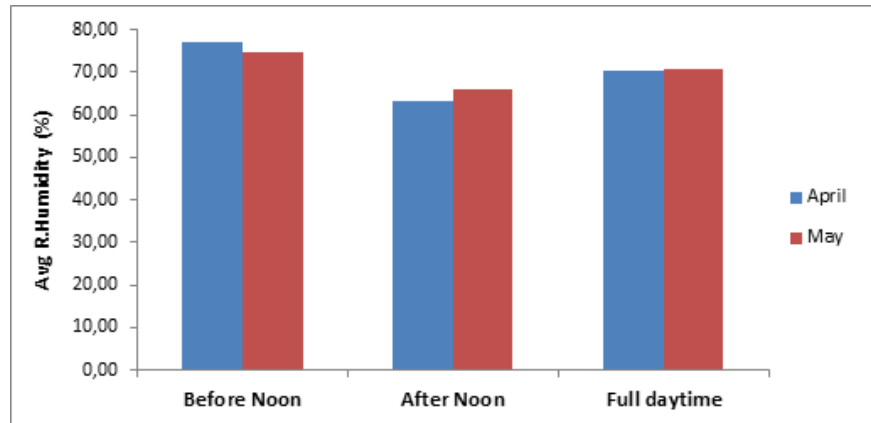

Figure 2. Average relative humidity against sections of the day

Figure 3 shows that the ambient temperature in the day before noon in the month of April is lower than that in the month of May, but the reverse is the case after noon. This is because the relative humidity in the day before noon in April is higher than that in May and the relative humidity in the day after noon is higher in May than in April. The full daytime average ambient temperature is the same.

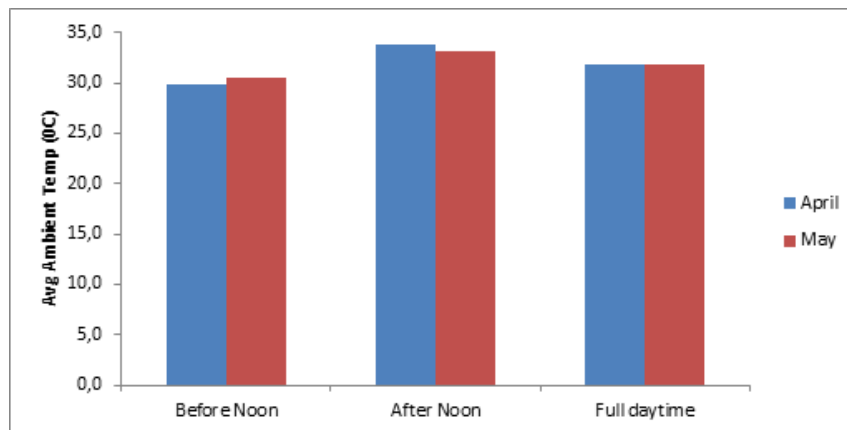

Figure 3. Average ambient temperature against sections of the day

Figure 4 shows a higher panel temperature in the day before noon in May than in April with the reverse occurring after noon. This corresponds to the fact that the ambient temperature before noon in May is higher than that in April while the ambient temperature after noon is higher in April than in May. The full daytime average panel temperature in both months is higher than the full daytime average ambient temperature which sits at 31.8°C.

Figure 5 shows the panel efficiency peaking at 77% in April against 73% in May. This results shows that photovoltaics are more efficient in April than in May, which corresponds to the fact that there is more sunshine in April than in May.

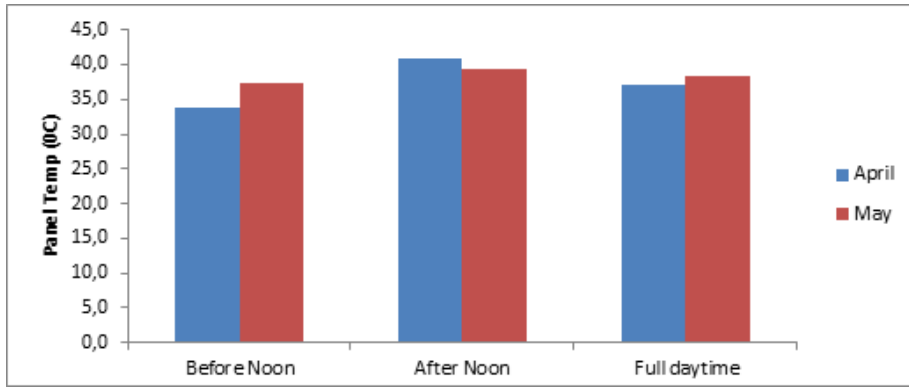

Figure 4. Average panel temperature against sections of the day

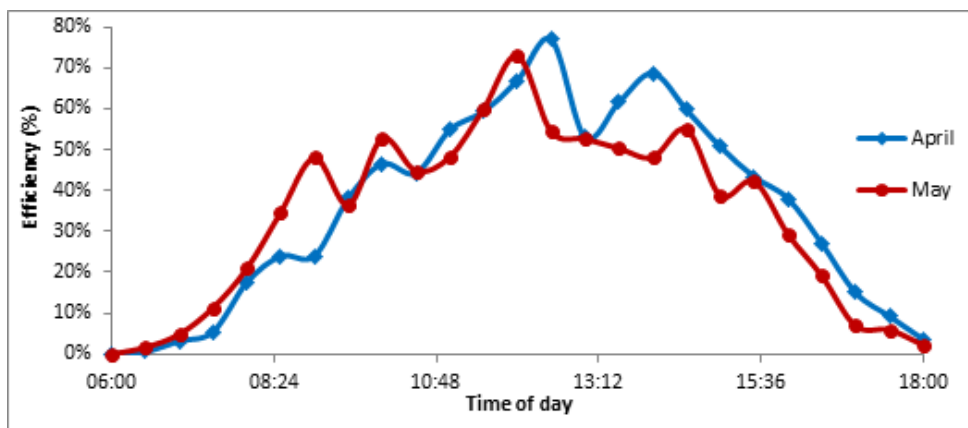

Figure 5. Efficiency against the time of the day

Figure 6 shows higher efficiency before noon in the month of May than in April, which is due to the early rising of the sun in the May.

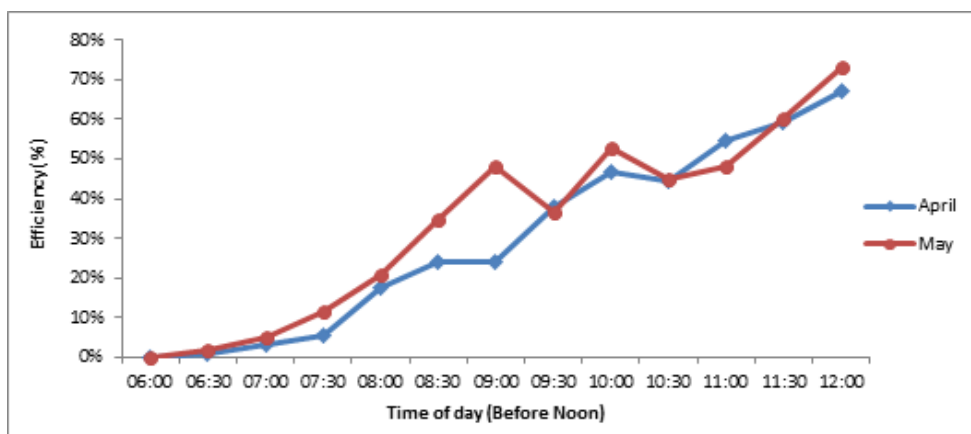

Figure 6. Efficiency against the time of the day (before noon)

While Figure 7 shows higher efficiency after noon in April than in May, which is due to the early setting of the sun in May. Figure 8 is in agreement with Figure 6 and Figure 7, while the full daytime average of Figure 8 corresponds to the explanation given in Figure 5.

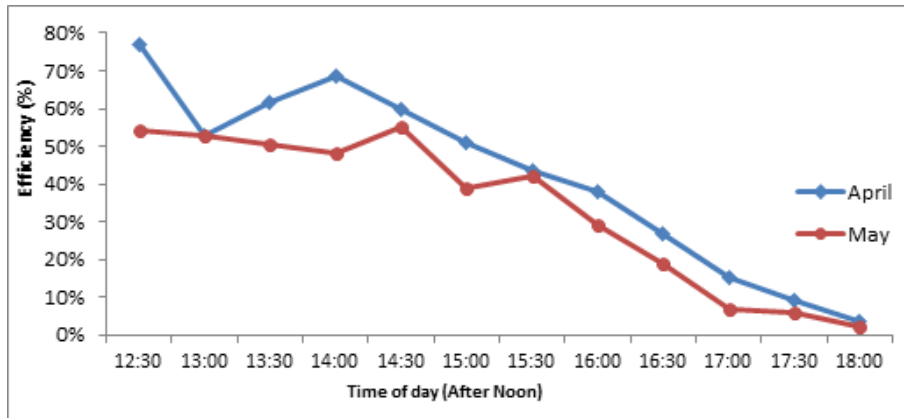

Figure 7. Efficiency against the time of the day (afternoon)

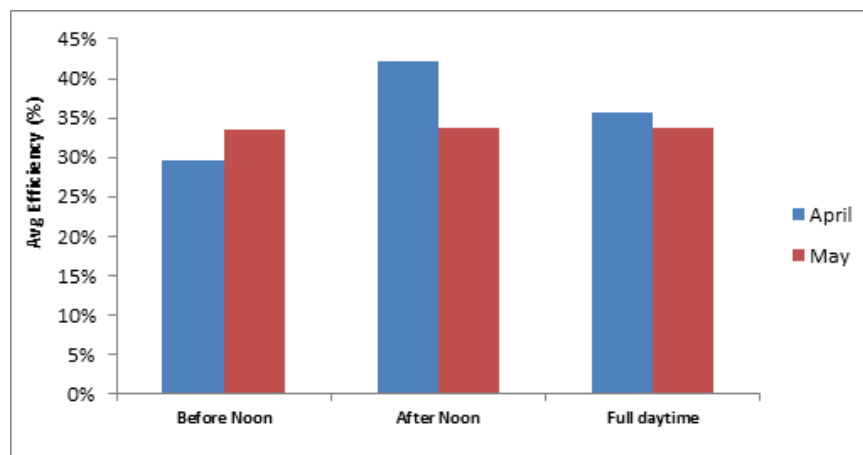

Figure 8. Average efficiency against sections of the day

5. CONCLUSION

This research shows that photovoltaics performs better in the month of April than in May, which is due to more sunshine experienced in April than in May couple with the slight difference in relative humidity. The result of this research alert the general public using photovoltaics as their source of electricity to expect different peak levels of efficiencies for different months, and also to expect the different peak levels of efficiencies to occur at different times of the day. The results of this research shows peak levels of efficiencies of 77% occurring at 12:30 and 73% occurring at noon for April and May respectively, which is due to the difference in sunrise and sunset times for both months. The research also give an insight that as we progress further into the month of June and July we should expect lower efficiencies from photovoltaics, and this efficiencies to occur at different times.

REFERENCES

- [1] Baghzouz, Y. "Photovoltaic Devices III". Retrieved March 6, 2017, from <http://www.egr.unlv.edu/~eebag/Photovoltaic%20Devices%20III.pdf>.
- [2] Dincar, I. (2003): The role of Energy in Energy Policy Making. *Energy Policy* Vol 30 137-149.
- [3] Ettah, E. B., Obiefuna, J. N. & Njar, G. N. (2011). The relationship between solar radiation and the efficiency of solar panels in Port Harcourt, Nigeria. *International Journal of Applied Science and Technology*, 1(4), 124-126.
- [4] Parker, A. (2000): Advantages of Solar Energy over Fossil Fuel; website: www.paker.sciencediscover.com.
- [5] Utama, N. P. S., Hartati, R. S., Ariastina, W. G., Swamardika, I. B. A., Penangsang, O. (2016). A Review on Model of Integrating Renewable Distributed Generation into Bali's Power Distribution Systems: Issues, Challenges and Possible Solutions. *Indonesian Journal of Electrical Engineering and Computer Science*, 4(2), 245-255.
- [6] Ozbay, H., Karafil, A., Onal, Y., Parmaksiz, H. (2017). The Monitoring of Monthly, Seasonal and Yearly Optimum Tilt Angles by Raspberry Pi Card for Bilecik City, Turkey. *Energy Procedia*, 113, 311-318.

- [7] Huld, T., Suri, M., Dunlop, E. D. (2008). Geographical variation of the conversion efficiency of crystalline silicon photovoltaic modules in Europe. *Progress in Photovoltaics*, 16(7), 595-607.
- [8] Gaur, A. & Tiwari, G. N. (2013). Performance of photovoltaic modules of different solar cells. *Journal of Solar Energy*, 2013: Article ID 734581, 13 pages.
- [9] Omubo-pepple, V. B., Isreal-cookey, C. & Alaminokuma, G. I. (2009). Effects of Temperature, Solar Flux and Relative Humidity on the Efficient Conversion of Solar Energy to Electricity. *European Journal of Scientific Research*, 35(2), 173-180.
- [10] Ettah, E. B., Udoimuk, A. B., Obiefuna, J. N. & Opara, F. E. (2012). The effect of Relative Humidity on the Efficiency of Solar Panels in Calabar, Nigeria. *Universal Journal of Management and Social Sciences*, 2(3), 8-11.
- [11] Ike, C. U. (2013). The Effect of Temperature on the Performance of a Photovoltaic Solar System in Eastern Nigeria. *International Journal of Engineering and Science*, 3(12), 10-14.
- [12] Hirata, Y., Inasaka, T., Tani, T. (1998). Output variation of photovoltaic modules with environmental factors-II: seasonal variation. *Solar Energy*, 63(3), 185-189.
- [13] Muhammad, A. B., Hafiz, M. A., Shahid, K., Muzaffar, A. & Aysha, M. S. (2014). Comparison of Performance Measurements of Photovoltaic Modules during Winter Months in Taxila, Pakistan. *International Journal of Photoenergy*, Volume 2014, Article ID 898414, 8 pages.
- [14] Mansur, T. M. N. T., Baharudin, N. H. & Ali, R. (2017). Performance Analysis of Self-Consumed Solar PV System for A Fully DC Residential House. *Indonesian Journal of Electrical Engineering and Computer Science*, 8(2), 391-398.
- [15] Verayiah, R. & Iyadurai, A. (2017). A comparison study on types of PV for grid connected photovoltaic power. *Indonesian Journal of Electrical Engineering and Computer Science*, 6(2), 349-356.
- [16] Syafiqah, Z., Irwan, Y. M., Amin, N. A. M., Irwanto, M., Leow, W. Z., & Amelia, A. R. (2017). Thermal and Electrical Study for PV Panel with Cooling System. *Indonesian Journal of Electrical Engineering and Computer Science*, 7(2), 492-499.
- [17] Adinoyi, M. J. & Said, S. A. M. (2013). Effect of dust accumulation on the power outputs of solar photovoltaic modules. *Renewable Energy*, 60, 633-636.
- [18] Leow, W. Z., Irwan, Y. M., Asri, M., Irwanto, M., Amelia, A. R., Syafiqah, Z. & Safwati, I. (2016). Investigation of solar panel performance based on different wind velocity using ANSYS. *Indonesian Journal of Electrical Engineering and Computer Science*, 1(3), 456-463.
- [19] Mejia, F., Kleissl, J. & Bosch, J. L. (2014). The effect of dust on solar photovoltaic systems. *Energy Procedia*, 49, 2370-2376.
- [20] Khanna, S., Reddy, K. S. & Mallick, T. K. (2018). Effect of climate on electrical performance of finned phase change material integrated solar photovoltaic. *Solar Energy*, 174, 593-605.
- [21] Armelia, A. R., Irwan, Y. M., Leow, W. Z., Irwanto, M., Safwati, I. & Zhafarina, M. (2016). Investigation of the Effect Temperature on Photovoltaic (PV) Panel Output Performance. *International Journal on Advanced Science Engineering Information Technology*, 6(5), 682- 688.
- [22] Mustapha, I., Dikwa, M. K., Musa, B. U. & Abbagana M. (2013). Performance evaluation of polycrystalline solar photovoltaic module in weather conditions of Maiduguri, Nigeria. *Arid Zone Journal of Engineering, Technology and Environment*, 9, 69-81.
- [23] Amajama, J., Ogbulezie, J. C., Akonjom, N. A. & Onuabuchi, V. C. (2016). Impact of Wind on the Output of Photovoltaic panel and Solar Illuminance/Intensity. *International Journal of Engineering Research and Generic Science*, 4(5), 137-142.
- [24] Times of sunrise and sunset. (n.d.). In Sunrisesunset. Retrieved November, 16, 2017, from <https://sunrisesunset.info/time-sunrise-sunset>
- [25] Njok, A. O. & Ogbulezie, J. C. (2018). The effects of relative humidity and temperature on polycrystalline solar panels installed closed to a river. *Physical Science International journal*, 20(4), 1-11.