

A new methodology for technical losses estimation of radial distribution feeder

Khairul Anwar Ibrahim¹, Mau Teng Au², Chin Kim Gan³

^{1,3}CeRIA Research Center, Faculty of Electrical Engineering, Universiti Teknikal Malaysia Melaka, Malaysia

²Institute of Power Engineering, Universiti Tenaga Nasional, Malaysia

Article Info

Article history:

Received Apr 7, 2019

Revised Jun 9, 2019

Accepted Jul 28, 2019

Keywords:

Energy efficiency

Power distribution network

Technical losses

ABSTRACT

Power distribution feeders is one of the key contributors of technical losses (TL) as it is typically large in numbers and scattered over large geographic areas. Traditional approach using classical formulation or time series load flow simulations to determine TL in each and every feeder and feeder sections in all distribution network require is an expensive exercise as it requires extensive modelling of the feeders and voluminous data. This paper presents a simple analytical approach to estimate monthly TL of a radial distribution feeder using analytical approach. TL for each feeder sections are evaluated on a monthly basis based on estimation of the load profile of the load points, peak power loss characteristics and loss factor. Total feeder TL are then estimated as the sum of all TL contributed by each feeder section. The developed models and procedure have been demonstrated through case studies performed on three (3) typical and representative feeders characterized by the different area served, number of feeder sections, load distribution and feeder length. The results shows close agreement (less than 5% differences) when compared with time series load flow simulations. With this model, the approach could be extended and applied to estimate TL of any radial distribution feeders of different configurations and characteristics.

Copyright © 2019 Institute of Advanced Engineering and Science.
All rights reserved.

Corresponding Author:

Khairul Anwar Ibrahim,
CeRIA Research Center,
Faculty of Electrical Engineering,
Universiti Teknikal Malaysia Melaka,
76100 Durian Tunggal, Melaka, Malaysia.
Email: khairulanwar@utem.edu.my

1. INTRODUCTION

Power utilities and regulators worldwide are putting greater emphasis to find ways to reduce energy losses in power delivery system as it represents key indicator of an energy efficient system [1, 2]. In any power delivery system, 100% energy efficiency simply means that, all the electrical energy channeled into the network are delivered and completely consumed and accounted for by each consumer without any waste or loss of energy. However, this has never been possible. As energy flow in each power delivery component, a certain proportion of the energy are lost at each component in every level between the source to the load point. Therefore, energy efficient distribution system implies the minimization of energy losses that occur in the power delivery network. The level (percentage) of energy efficiency of power delivery network to deliver energy can be generally calculated as shown in (1).

$$E_{Loss} [\%] = \frac{E_{delivered}[MWh] - E_{consumed}[MWh]}{E_{delivered}[MWh]} \times 100\% \quad (1)$$

Where:

- E_{Loss} = total energy losses (generation, transmission and distribution)
- $E_{delivered}$ = energy delivered (measured) at the generation system point
- $E_{consumed}$ = energy consumed and billed at end-customer

Distribution energy losses can be broken down into technical losses (TL) and non-technical losses (NTL) [3, 4]. TL are associated with the inevitable and inherent loss of energy due to energized equipment and current flowing through resistive distribution components [5]. TL can be measured using energy meters or computed based on the network’s electrical properties, such as resistance, reactance, voltage, current, and power [6, 7]. Meanwhile, NTL are those energy units that are delivered for consumption but are not accounted or paid for, as a consequence of consumer pilferages, energy theft, faulty or incorrect billing [8].

Studies have shown that the average TL in distribution network worldwide ranges between 5% and 10% of the total energy delivered, of which mostly coming from the distribution network [9, 10]. Distribution TL degrades the network performance and economic efficiency and increases system capacity, hence, resulting in billions of financial losses and increase in cost of investment [11-13]. The cost of TL and cost of investment in reducing TL can also significantly affect the consumer’s price or tariff of electricity. In some countries, as the privately-owned distribution network operation (DNO) do not directly bear these costs, the cost of TL is transferred as part of service cost to the customers. Consequently, regulatory bodies are imposing new regulations for DNO to reduce losses in their networks to a prescribed standard level or they will be penalized [14]. Also, distribution TL contributes to excessive greenhouse gases (GHG) emission, assuming it is entirely produced by fossil-fueled power generation plant [15, 16]. TL in distribution network can be reduced in many ways such as power factor correction, voltage optimization, network augmentation (e.g. increase conductor size), network reconfiguration (optimization), optimal sizing and location of DG and many more [9, 17, 18].

In a distribution network, majority of TL are contributed by feeders and transformers connected to the network. This paper concerns with TL in distribution feeders, hence, TL for transformers is not the scope of this paper. In this sense, the decrease of feeder TL which will improve the efficiency of network’s operation are constantly desired goals for utilities and regulators.

1.1. Technical Losses In Distribution Feeders

Electrical energy flows through multiple feeder sections to serve all connected loads. Sometimes, one or more line branches (or laterals) branch emanates from the main feeders. Each MV feeder and/or feeder section can be fairly short, on the order of a few or less than 1 km, or it can be as long as several tens of km, depending on the distance from the substation to the load point. Furthermore, the magnitude of load along connected at each load point (or load distribution) along feeder also varies at every demand period.

TL in distribution feeder is primarily caused by “ I^2R losses” which means that demand profiles containing large peaks lead to significantly more TL than flat demand profiles, even if the average power usage is the same. Theoretically, the power losses (MW) of a typical feeder in Figure 1 at any time t can be described using (2) and (3) [19]. The total TL for the entire feeder is then calculated as the sum of all TL contributed by all feeder section using (4). As shown in (2) is useful in calculating power (MW) losses only when all the operating condition and the detail parameters for each feeder section are known.

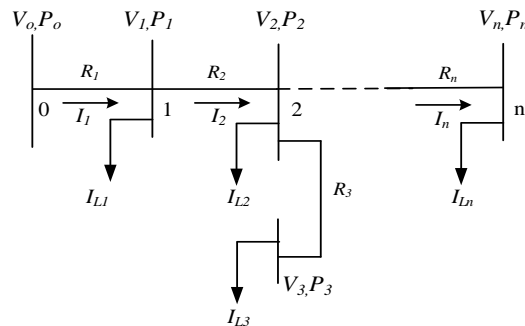

Figure 1. One line diagram of a typical radial feeder

$$P_i^{Loss,fd} = R_i \times I_i^2 = R_i \times \frac{P_i^2}{V_i^2} \tag{2}$$

$$E_i^{Loss,fd} = \int_{t=0}^T P_i^{Loss,fd}(t) dt = R_i \times \int_{t=0}^T I_i^2(t) dt \quad (3)$$

$$E_i^{Loss,fd}(total) = \sum_{i=1}^n \left(R_i \times \int_{t=0}^T I_i^2(t) dt \right) \quad (4)$$

Where:

$P_i^{Loss,fd}$	= power losses of the i^{th} feeder section
$E_i^{Loss,fd}$	= energy losses in feeders of the i^{th} feeder section
$E_i^{Loss,fd}(total)$	= total feeder energy losses
I_i	= current flowing of the i^{th} feeder section
P_i	= real power of the i^{th} feeder bus/load point
V_i	= voltage of the i^{th} bus
R_i	= total resistance of the i^{th} feeder section
i	= feeder section/bus number/load point
n	= total number of feeder section / busses
T	= the time period of interest

Calculating TL using the above TL formulae is difficult since they vary at every feeder section in the system due to variations in conductor resistance and current, caused by different length, load distribution, topology of the feeders [20]. It requires voluminous data collection and rigorous effort to develop, update and simulate/calculate the network and feeder model and many of the operating conditions occurring within the period are not known beforehand [21-23]. Therefore, due to these practical difficulties, distribution feeder's TL are approximated using different approaches, such as the load factor approach.

1.2. Existing Methodologies to Determine Distribution Feeder Technical Losses

The definitive/straight forward method to assess feeder TL is to install energy meters at strategic locations along feeders to record the energy in and out of the individual feeder sections or any network component, of which would be a costly exercise [24]. Thus, to avoid this costly exercise, computational modelling such as load flow approach are used to perform TL assessment.

The use of time-interval load flow simulations are widely used to accurately analyze TL in distribution feeders [25-27]. However, for accurate calculation of system wide distribution network, using these methods require in-depth knowledge and detail modelling of the distribution feeder. As the size of the network grows, the computation time, data and storage requirement increases exponentially. Artificial intelligence techniques, such as fuzzy logic [28] and clustering algorithm [29] are also applied to solve the problem, which requires large datasets to be trained to estimate TL. When the complete set of networks and energy metering data are not available, the prevailing method to estimate TL in the distribution network is to use the "load loss factor" method [30]. Benchmark network were used to infer TL of large distribution network according to their clusters [23, 24, 31]. However, since it is unlikely that any two networks and/or feeders exhibit the same characteristics, the benchmarking approach to infer TL of large distribution network might not yield acceptable results [32].

To address these practical difficulties, estimation of distribution feeder TL is still an aspect of great interest, as shown by the number of different studies performed on this subject. There is still need for researchers to further develop a more effective approach to estimate distribution feeder TL in the event of inadequate or even unavailability of accurate network and energy metering data. This paper attempt to cover such a knowledge gap, through developing an analytical approach to estimated TL in feeder and feeder sections in the absence of detail energy meter data in feeders and reducing the use of load flow simulations. The idea of establishing an analytical approach to estimate TL of a radial distribution feeder (i.e. with unidirectional power flow) is proposed. TL for each feeder sections are evaluated on a monthly basis based on estimation of the load profile of the load points, peak power loss generic characteristics and load loss factor method. Total feeder TL are estimated as the sum of all TL contributed by each feeder section. This paper continues and completes the preliminary research presented by the same authors in [33], extending feeder TL estimation model.

2. RESEARCH METHOD

This paper propose a new method to estimate distribution feeder TL using analytical approach. The feeder model is a traditional distribution feeders (without any distributed energy resources) which operated in radial configurations. In this model, the load is assumed balanced in all three phases and there's no TL due to current in ground cables. Figure 2 shows a general radial distribution feeder with n feeder

sections. As the total infeed energy flows into each feeders from the source to each load point, a proportion of the energy are lost in each feeder sections, mainly as I^2R losses. The level of TL associated with each feeder sections are influenced by a number of key parameters such as feeder length (l), load segment composition and distribution, topology, feeder loading and cable size. Each feeder sections between two (2) load points have different length and carry different amount of load.

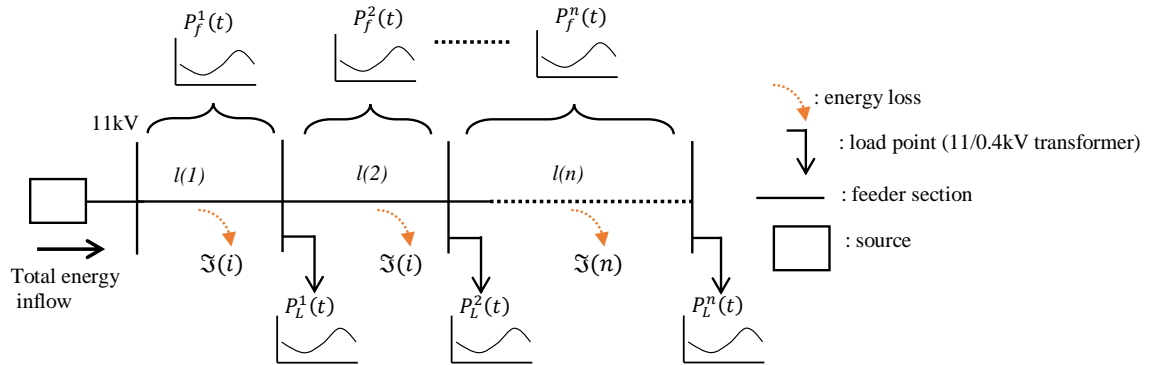

Figure 2. Radial distribution feeder single line model with n feeder sections

The load profile of the feeder sections depends on the amount of load characteristic measured at each of the load points and can be recorded using Smart Meters at all load points. However, due to economic reasons, not all load points are equipped with energy meters, hence, it is often times estimated or using sample measurement or typical load profile. Thus, in this work, analytical equations based on feeder section length, peak demand, peak power loss (PPL), load factor (LF) and loss factor (LsF) are formulated to describe the energy loss for each feeder section as well as for the entire feeder. The LF and LsF are key to estimate TL in distribution feeders and are one of the prevailing method used by utilities to estimate TL in the distribution network due to when complete set of networks and loads data are not available [34, 30]. This study shall adopt this approach as part of the overall proposed method.

The load for any i^{th} feeder section, ($P_f^i(t)$), during the time period T can be derived by aggregating the load at each downstream load point ($P_L^i(t)$) at all $t = 0 \dots T$. For n numbers of feeder sections and load points, the load profile for the first feeder section can be calculated as the coincident sum of all the load profile at load point 1 to n as shown in (5). The second feeder section is derived based on coincident sum from load profile at load point 2 to n ; so on and so forth. The 30-days energy loss (in MWh) for each i^{th} feeder section (\mathfrak{S}_i) can be estimated based on its peak power loss (\wp_i), loss factor (\mathcal{L}_i) and the time period (1 month = 720 hours), as shown in (6) and (7).

To further simplify the task, a set representative composite load profile, and the corresponding LF, are estimated for each load point to represent the type and composition of different load segment type. These data are obtained from local power utility based on load survey, as shown in Figure 3.

$$P_f^i(t) = P_L^i(t) + P_L^{i+1}(t) + \dots + P_L^n(t), \text{ for all } t = 0 \dots T \tag{5}$$

$$\mathfrak{S}_i = \wp_i \times \mathcal{L}_i \times 720, \text{ for all } i = 0 \dots n \tag{6}$$

$$\mathcal{L}_i = \alpha \cdot F_i + (1 - \alpha) \cdot \mathcal{F}_i^2, \text{ for all } i = 0 \dots n \tag{7}$$

Where:

- ρ_i = peak power demand of i^{th} feeder section
- l_i = length of i^{th} feeder section
- \mathcal{F}_i = load factor of i^{th} feeder section
- \mathcal{L}_i = loss factor of i^{th} feeder section
- α = loss factor coefficient
- a_B, b_B, c_B, d_B = polynomial coefficients of base case PPL equation for feeder section
- \wp_i = peak power loss for the i^{th} feeder section
- σ_i = PPL correction factor due to length of the i^{th} feeder section

- \mathfrak{S}_i = energy losses of i^{th} feeder section
- \mathfrak{S}_F = energy losses of feeder
- $P_f^i(t)$ = aggregated 24 hours load profile for the i^{th} feeder section
- $P_L^i(t)$ = representative 24 hours load profile for the i^{th} load point
- n = total number of feeder section

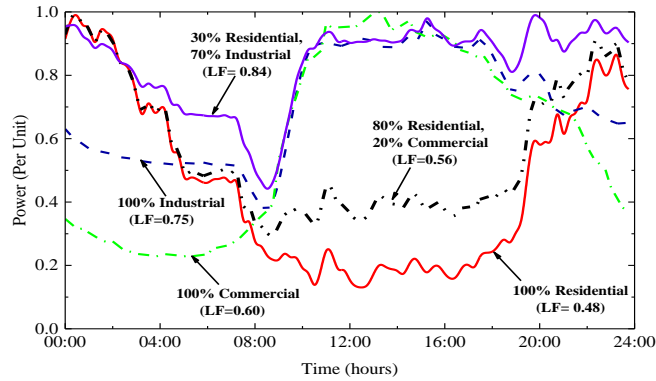

Figure 3. Load profile curves and LF [33]

As shown in (2), the PPL of each feeder section (φ_i) depends on its PPD in MW, which varies over time. Traditionally, the normal method is to run load flow simulations for each feeder to find the PPL for each PPD, which is inefficient. To simplify analysis, this paper propose to develop a generic equation which enable user to estimate the PPL of feeder section at any value of PPD. To do this, a base case PPL characteristic equation is developed using regression analysis of load flow results. The base case feeder section is modelled in DigSILENT Powerfactory as a single feeder connected to a single end-point load, as shown in Figure 4. Static load flow simulations are conducted at 10%, 30%, 50%, 70%, 90% and 100% loading and the PPL at each PPD is plotted to obtain the third order polynomial regression equation. A sample result conducted on a sample base 11kV feeder is shown in Figure 5. This equation is then used to estimate the PPL of the feeder sections for any PPD for feeder of the same length and size as the base case feeder.

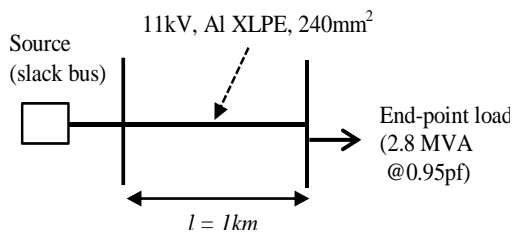

Figure 4. Single line model of base case feeder section

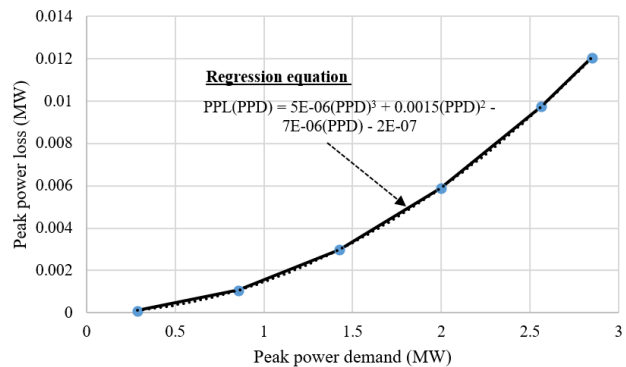

Figure 5. Example regression equation of peak power loss for a single 11kV feeder section

To improve the accuracy of estimating PPL based on PPD, the PPL regression equation then need to be corrected to cater for different feeder length. From [33], it is shown that feeder PPL equation is linearly correlated with cable length. Thus, the correction factors due to length is just established by simply multiplying the PPL equation with the ratio of the length of the feeder of interest (l_i) to the base case feeder

length (l_b), as shown in (8). The coefficients a, b, c and d are the PPL coefficients for the base case feeder section and is obtained from the graph shown in Figure 5. This equation then is used to find the 30-days TL for each of feeder section with different PPD and length. Finally, the total feeder TL (\mathfrak{S}_f) can be calculated by taking the sum of TL of each of the feeder sections (\mathfrak{S}_i), as shown in (9). The next section shall present case studies to estimate feeder losses on three (3) type of representative feeders using the proposed method. Figure 6 shows the flowchart of the overall methodology proposed in this paper.

$$\rho_b = \frac{l_i}{l_b} \times \{a\rho_i^3 + b\rho_i^2 - c\rho_i - d\} \tag{8}$$

$$\mathfrak{S}_f = \sum_{i=1}^n \mathfrak{S}_i \tag{9}$$

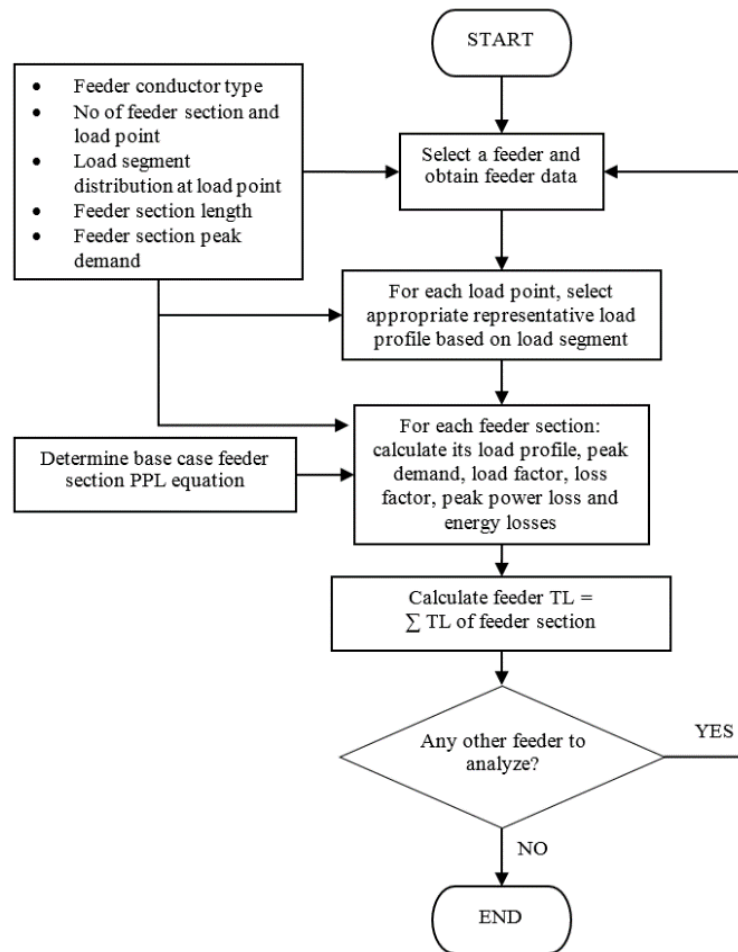

Figure 6. A flow chart of the proposed distribution feeder TL estimation methodology

3. CASE STUDY

The proposed methodology are demonstrated through several case studies based on a set of representative feeders (RF) which is a generic and typical feeders found based on different types of area served created in reference [35]. All RF, including the base case feeder comprises of 11kV, 240mm², 3 core, Al XLPE cable type. While the length of the base case feeder section is chosen to be 1km, the length of RF varies, depending on the location of the area served. To simplify analysis, the loads at each load points are assumed under balanced condition, with power factor of 0.95 and the voltage is assumed constant along feeder. In addition, the 30-days energy loss also assume that, the estimated load profile of the load point does not vary significantly for the entire loss calculation period. These generic characteristics of the RF under study are summarized in Table 1.

The 30-days TL are calculated for each feeder using the above-mentioned method. The TL estimation is then validated against 15-minutes time interval load flow simulation. It is important to note that, despite of the generalized method proposed in this paper, the RF type presented and represents the typical distribution feeder found in the local power utility and cannot be prescribed over the board. For feeder of different type, further addition and modification of the values of the parameters (e.g. PPL regression equation) need to be repeated. Also, in this study, the loss factor coefficient, α , is assumed to be 0.25, based on a study performed in reference [33].

Table 1. Case Study Representative Feeder Characteristics

RF Type	Feeder PPD in MW	Load distribution/concentration	No of load points (and feeder sections)	Load segment composition	Total feeder length (<i>l</i>) in km	Description of load area served
1	High (>4MW)	Near feeder source	5	100% Commercial	4.1	High density commercial area
2	Medium (between 2~3mw)	Near feeder source	10	Mixed (70% Residential, 30% Commercial)	13.7	Residential township at semi urban area
3	Low (<2MW)	Concentrated near feeder end	10	100% residential	20.2	Remote villages/rural

4. RESULTS AND DISCUSSION

Results of the case study are organized in two (2) parts: (a) estimation of feeder TL (b) validation with time series load flow simulation. Table 2 and 3 shows the results of the 30 days TL estimation for each feeder section along the feeder as well as for the total feeder TL. TL results obtained based on the proposed approach shows consistency with changes in the feeder section's characteristics. The TL of the feeder and feeder sections can be ranked accordingly, hence, it provides useful information to assist network planners to prioritize TL mitigation plan. It can be see that, although the average feeder length are short, the highest losses is observed in feeder section 1 as it has the highest PPD and LF. For RF type 2, even though the PPD for feeder section 1 and 2 are close to the rest of the feeder sections, the high losses of the two feeder sections are mainly contributed by high PPD and longer feeder length. The length of feeder section 10 is the highest among all in the same feeder but, the TL is lowest due to low PPD. From Table 3, the results of the total feeder TL when compared with time series load flow simulations shows less than 5% in differences. This shows that the proposed method yields reasonably accurate results.

Table 2. TL Estimation for Case Studies

RF Type	Feeder section	Length (km)	PPD at load point (MW)	LF	LSF*	Estimated branch section PPD (MW)	PPL of feeder section (MW)	30-days TL (MWh)
1	1	0.8	0.93	0.575	0.367	4.044	0.019515	5.50
	2	1	0.89	0.562	0.352	3.130	0.014560	3.95
	3	0.6	0.87	0.541	0.330	2.276	0.004604	1.17
	4	1	0.7	0.513	0.301	1.410	0.002932	0.69
	5	0.7	0.75	0.516	0.304	0.750	0.000578	0.14
2	1	0.9	0.25	0.635	0.438	2.294	0.007016	2.33
	2	2.1	0.35	0.656	0.465	2.049	0.013041	4.57
	3	1.1	0.22	0.594	0.389	1.849	0.005562	1.65
	4	1.5	0.17	0.609	0.407	1.641	0.005969	1.85
	5	1.2	0.32	0.570	0.361	1.545	0.004227	1.17
3	6	1.3	0.18	0.599	0.394	1.232	0.002908	0.83
	7	0.8	0.41	0.620	0.420	1.061	0.001324	0.40
	8	1.6	0.29	0.460	0.249	0.802	0.001511	0.27
	9	1.7	0.23	0.452	0.241	0.532	0.000704	0.12
	10	1.5	0.31	0.445	0.235	0.310	0.000209	0.04
3	1	1.2	0.11	0.465	0.254	1.808	0.005796	1.16
	2	1.4	0.13	0.466	0.254	1.700	0.005975	1.20
	3	1.3	0.11	0.464	0.252	1.583	0.004812	0.96
	4	2.5	0.12	0.464	0.252	1.477	0.008048	1.61
	5	2.1	0.11	0.464	0.253	1.361	0.005736	1.15
	6	1.9	0.1	0.466	0.254	1.251	0.004382	0.80
	7	2.6	0.25	0.466	0.254	1.154	0.005102	0.93
	8	2.6	0.32	0.461	0.250	0.925	0.003273	0.59
	9	1.9	0.33	0.453	0.242	0.629	0.001101	0.19
	10	2.7	0.31	0.445	0.235	0.310	0.000377	0.06

Table 3. Validation of TL Estimation with Time Series Load Flow Simulations

RF type	Estimated total feeder TL (MWh)	Simulated feeder TL (time series) (MWh)	Difference (MWh)	% Difference
1	11.45	11.87	0.42	3.51
2	13.23	12.74	0.49	3.87
3	8.66	8.94	0.29	3.19

5. CONCLUSION

Knowing that distribution feeders represent a significant contribution to TL, it is necessary for utilities to obtain a clear information on its level, location and cause of TL. A new and effective method for estimation TL of distribution feeder are proposed. The proposed analytical approach of using representative load profile and load loss factor formulation to estimate TL in each feeder sections is shown to be efficient. It is also robust and could be easily modified to perform TL estimation for different types and configurations of distribution feeders.

The case study shows that, TL for large number of distribution feeder could be efficiently estimated on a monthly basis using minimal load flow simulation and minimal type of data required. TL results of distribution feeders estimated on a regular basis are useful to monitor the TL trend in the feeders. Operational plan in terms of reconfiguring the network by changing normal off points could be formulated to minimize TL of distribution feeders. Additionally, TL in the distribution feeders could be useful input for decision making in network augmentation.

Future research work could be extended to include estimation of feeder TL with bidirectional power flow due to penetration of distributed generation, effect of harmonics and unbalanced condition. In addition, future research could also consider TL in ground cables as well as the effect of laterals to the feeder TL calculation. This methodology is useful in countries that Smart Meters are far from reality and the resources are scarce, so the system wide estimation could be performed with reasonably accurate results efficiently

ACKNOWLEDGEMENTS

The authors would like to thank the Malaysian Ministry of Higher Education (MOHE), (grant number RACER/1/2019/TK07/UTEM//3) for the providing the financial support for this project. The authors wish to acknowledge the support from Center of Robotics and Industrial Automation (CeRIA) of Faculty of Electrical Engineering (FKE), Universiti Teknikal Malaysia Melaka (UTeM), Faculty of Electrical and Electronic Engineering Technology (FTKEE) for supporting this research as well as Institute of Power Engineering of Universiti Tenaga Nasional (UNITEN) for providing the data for the study.

REFERENCES

- [1] The World Bank, "Toward a sustainable energy future for all: directions for the World Bank Group's energy sector," 2013.
- [2] The World Bank, "Reducing Technical and Non-Technical Losses in The Power Sector," 2009.
- [3] J. J. Grainger and T. J. Kendrew, "Evaluation of technical losses on Electric distribution systems," in *10th International Conference on Electricity Distribution*, 1989, vol. 6, pp. 488–493.
- [4] E. S. Ibrahim, "Management of loss reduction projects for power distribution systems," *Electr. Power Syst. Res.*, vol. 55, no. 1, pp. 49–56, 1999.
- [5] A. Rossoni, P. Alegre, R. D. Trevizan, A. S. Bretas, S. Halpern Braunstein, and N. G. Bretas, "Smart Distribution Power Losses Estimation : A Hybrid State Estimation Approach," in *Power and Energy Society General Meeting (PESGM)*, 2016.
- [6] N. E. Chang, "Determination of Primary-Feeder Loss," *IEEE Trans. Power Appar. Syst.*, vol. 87, no. 12, pp. 1991–1994, 1968.
- [7] D. I. H. Sun, S. Abe, R. R. Shoults, C. M.S., E. P., and F. D., "Calculation Of Energy Losses In A Distribution System," *IEEE Trans. Power Appar. Syst.*, vol. 75, no. 5, pp. 969–977, 1980.
- [8] T. E. Somefun, C. O. A. Awosope, and A. Chiagoro, "Smart prepaid energy metering system to detect energy theft with facility for real time monitoring," *Int. J. Electr. Comput. Eng.*, vol. 9, no. 5, pp. 4184–4191, 2019.
- [9] S. C. Vegunta, M. J. Barlow, D. Hawkins, A. Steele, and S. A. Reid, "Electrical Losses Reduction in the UK Isle of Wight 11 kV Distribution Network - Case Study," *IEEE Trans. Power Syst.*, vol. 31, no. 6, pp. 4427–4434, 2016.
- [10] Sohn Associates and Imperial College London, "Management of electricity distribution network losses," 2014.
- [11] G. Grigoras, G. Cartina, M. Istrate, and F. Rotaru, "The Efficiency of the Clustering Techniques in the Energy Losses Evaluation from Distribution Networks," *Int. J. Math. Model. Methods Appl. Sci.*, vol. 5, no. 1, pp. 133–141, 2011.
- [12] I. E. Davidson, A. Odubiyi, M. Kachienga, and B. Manhire, "Technical loss computation and economic dispatch model for T & D systems in a deregulated ESI," *Power Eng. J.*, vol. 16, no. 2, pp. 55–60, 2002.

- [13] ABB Inc, "Energy Efficiency in the Power Grid Energy Efficiency in the Power Grid," 2007.
- [14] V. H. M. Quezada, J. R. Abbad, T. Gómez, and S. Román, "Assessment of Energy Distribution Losses for Increasing Penetration of Distributed Generation," *IEEE Trans. Power Syst.*, vol. 21, no. 2, pp. 533–540, 2006.
- [15] R. A. Begum, K. Sohag, S. M. S. Abdullah, and M. Jaafar, "CO₂ emissions, energy consumption, economic and population growth in Malaysia," *Renew. Sustain. Energy Rev.*, vol. 41, pp. 594–601, 2015.
- [16] P. Mancarella, C. K. Gan, and G. Strbac, "Optimal design of low-voltage distribution networks for CO₂ emission minimisation. Part I: model formulation and circuit continuous optimisation," *IET Gener. Transm. Distrib.*, vol. 5, no. 1, p. 38, 2011.
- [17] S. M. Ali, P. S. Babu, and B. Gurusekhar, "Reconfiguration with Simultaneous DG installation to Improve the Voltage Profile in Distribution Network using Harmony Search Algorithm," *Bull. Electr. Eng. Informatics*, vol. 4, no. 4, pp. 257–273, 2015.
- [18] M. N. Bin Kamarudin, T. J. T. Hashim, and A. Musa, "Optimal sizing and location of distributed generation for loss minimization using firefly algorithm," *Indones. J. Electr. Eng. Comput. Sci.*, vol. 14, no. 1, pp. 421–427, 2019.
- [19] W. H. Kersting, *Distribution System Modeling and Analysis*. CRC Press, 2012.
- [20] K. Malmedal and P. K. Sen, "A better understanding of load and loss factors," *IAS Annu. Meet. - IEEE Ind. Appl. Soc.*, pp. 1–6, 2008.
- [21] C. C. B. Oliveira *et al.*, "A new method for the computation of technical losses in electrical power distribution systems," *Electr. Distrib. 2001. Part 1 Contrib. CIREN. 16th Int. Conf. Exhib. (IEE Conf. Publ No. 482)*, vol. 2001, no. 482, pp. 5–pp, 2001.
- [22] H. M. Khodr *et al.*, "Standard levels of energy losses in primary distribution circuits for SCADA application," *IEEE Trans. Power Syst.*, vol. 17, no. 3, pp. 615–620, 2002.
- [23] C. A. Dortolina and R. Nadira, "The loss that is unknown is no loss at all: A top-down/bottom-up approach for estimating distribution losses," *IEEE Trans. Power Syst.*, vol. 20, no. 2, pp. 1119–1125, 2005.
- [24] A. K. Dashtaki and M. R. Haghifam, "A new loss estimation method in limited data electric distribution networks," *IEEE Trans. Power Deliv.*, vol. 28, no. 4, pp. 2194–2200, 2013.
- [25] Z. Mahmoodzadeh, N. Ghanbari, A. Mehrizi-sani, M. Ehsan, and C. Science, "Energy loss estimation in distribution networks using stochastic simulation," in *IEEE Power & Energy Society General Meeting*, 2015, pp. 1–5.
- [26] R. Cespedes, H. Duran, H. Hernandez, and A. Rodriguez, "Assessment of electrical energy losses in the Colombian power system," *IEEE Trans. Power Appar. Syst.*, vol. PAS-102 No, no. 6, pp. 2425–2433, 1983.
- [27] N. Mohamed and D. Ishak, "Improved load flow formulation for radial distribution networks," *Indones. J. Electr. Eng. Comput. Sci. Vol.*, vol. 15, no. 3, pp. 1144–1153, 2019.
- [28] M. Barukcic, S. Nikolovski, and Z. Hederic, "Estimation of Power Losses on Radial Feeder Using Minimum Electrical Measurements and Differential Evolution Method," *Int. J. Soft Comput. Softw. Eng.*, vol. 2, no. 4, pp. 1–13, 2012.
- [29] S. Wang, P. Dong, and Y. Tian, "A Novel Method of Statistical Line Loss Estimation for Distribution Feeders Based on Feeder Cluster and Modified XGBoost," *Energies*, vol. 10, no. Dlc, 2017.
- [30] C. L. Leonardo M. O. Queiroz, Marcio A. Roselli, Celso Cavellucci, "Energy Losses Estimation in Power Distribution Systems," *IEEE Trans. Power Syst.*, vol. 27, no. August, pp. 1–120, 2012.
- [31] R. Nadira, S. Benchluch, and C. A. Dortolina, "A novel approach to computing distribution losses," *IEEE PES Transm. Distrib. Conf. Expo.*, vol. 2, no. 4, pp. 3–7, 2003.
- [32] P. S. N. Rao and R. Deekshit, "Energy loss estimation in distribution feeders," *IEEE Trans. Power Deliv.*, vol. 21, no. 3, pp. 1092–1100, 2006.
- [33] K. A. Ibrahim, M. T. Au, C. K. Gan, and J. H. Tang, "System wide MV distribution network technical losses estimation based on reference feeder and energy flow model," *Int. J. Electr. Power Energy Syst.*, vol. 93, pp. 440–450, 2017.
- [34] T. Gönen, *Electric Power Distribution System Engineering 2nd Ed*, 2nd ed. New York: McGraw-Hill, Inc, 2008.
- [35] K. A. Ibrahim, M. T. Au, and C. K. Gan, "Generic Characteristic of Medium Voltage Reference Network for the Malaysian Power Distribution System," *SCORED 2015 (IEEE Proceedings)*, pp. 204–209, 2015.

BIOGRAPHIES OF AUTHORS



Dr. Khairul Anwar Ibrahim finished his Bachelor degree in Electrical Power Engineering from Rensselaer Polytechnic Institute (RPI), New York, USA. In 2002, he finished his Masters degree from RPI in the same field. From 2002-2006, he worked as maintenance and operation engineer at the Tuanku Ja'afar Power Station, Port Dickson, Negeri Sembilan, Malaysia. From 2006-2009, he worked at TNB Research Sdn. Bhd, Kajang, Selangor as a researcher. Since 2010, he works as a Senior Lecturer at University Teknikal Malaysia Melaka (UTeM). In 2018, he finished his PhD in Electrical Engineering from Universiti Tenaga Nasional (UNITEN). His research interests includes energy efficiency, energy losses and power distribution network. E-mail: khairulanwar@utem.edu.my



Prof. Dr. Ir. Au Mau Teng received his B.S.E.E (Cum Laude) from University of Toledo, USA, and his M.S.E.E from Purdue University, USA, M.S.E.E (Energy and Control). Later, he obtained his PhD from University of Manchester UK in Power Systems. He is a professional engineer and is a member in MIEM, MIEEE, Professional Engineer with Practicing Certificate (Electrical). He has been in numerous post in Tenaga Nasional Berhad, including managerial post in TNB Distribution since 1980-199 and a lecturer in UNITEN from 1998 to 2015. He was also a director of Power Engineering Center from 2008- 2016. Currently, he is a Professor in Institute of Power Engineering, UNITEN. His research interest includes power distribution design and planning, power stability and power quality. E-mail: Mtau@uniten.edu.my



Assoc. Prof. Dr. Ir. Chin Kim Gan received his B.Eng and M.Sc degree both in electrical engineering from Universiti Teknologi Malaysia (UTM) and Ph.D degree from the Imperial College London, UK. He is currently an Associate Professor at Universiti Teknikal Malaysia Melaka (UTeM), Malaysia and also a registered Professional Engineer with the Board of Engineers Malaysia (BEM). His research interests are distribution network design integration of renewable energy and Smart Grid. E-mail: ckgan@utem.edu.my