

# A Novel Method Based on Biogeography-Based Optimization for DG Planning in Distribution System

Mohammad Sedaghat\*, Esmaeel Rokrok, Mohammad Bakhshipour

Department of Electrical Engineering, Lorestan University,  
Daneshgah Street, 71234-98653, Khorramabad, Lorestan, Iran

\*Corresponding author, e-mail: mohammadsedaghat74@gmail.com

## Abstract

*This paper proposed a novel technique based on biogeography-based optimization (BBO) algorithm in order to optimal placement and sizing of distinct types of Distributed Generation (DG) units in the distribution networks which is applied to improve voltage profile as the main factor for power quality improvement and reduce power losses. In order to promote the investigation to be capable in practical terms, the loads are linearly varied in small steps of 1% from 50% to 150% of the base value. The optimal size and location of distinct types of DGs are found out in each load step. This will aid the distribution network operators (DNOs) to have a long term scheduling for the optimal management of DG units and achieve the maximum performance. To verify the efficiency of proposed method, it has been conducted to IEEE 33-bus radial distribution system. Also, simulation results are compared with the analytical approach and HPSO algorithm (mixed binary and typical particle swarm optimization algorithm). The obtained simulation results demonstrate the better performance and effectiveness of the proposed method.*

**Keyword:** distributed generation, long-term scheduling, load variations, voltage profile, power loss, biogeography-based optimization (BBO)

**Copyright © 2015 Institute of Advanced Engineering and Science. All rights reserved.**

## 1. Introduction

The definition of the distributed generation is a generation of power by facilities that are adequately smaller than central generating plants and can be adjoined at nearly any point in power system [1, 2]. Due to the considerable progression in several generation technologies, power systems deregulation, environmental effects and fabrication issues of new transmission lines, the penetration level of DGs in power network have been developing during the last decade [3, 4]. In addition DG may result in various advantages such as control of voltage profile, ancillary services, improving in power quality and reliability characteristics, loss decrement, energy savings and distribution capacity deferral [5-11]. Lately, numerous papers have been presented to study the problems of optimal allocation and sizing in various condition. Using analytical method, the power loss minimization of system was preformed by suitable DG allocation [12]. An approach based on multi-objective index which was utilized to reduce voltage drop and power loss was suggested in [13]. In order to optimize corrective actions, planning and operation of distribution network, an algorithm based on multi-objective GA was recommended in [14, 15].

From the methodology point of view, several algorithms have been utilized for suitable DG allocation such as improved PSO technique [16], hybrid GA and simulated annealing [17], combined GA and PSO [18], tabu search [19], non-linear and dynamic programming [20, 21], differential evolution algorithm [22], artificial bee colony algorithm (ABC) [23] harmony search algorithm [24]. This study proposes a novel approach based on BBO algorithm which is investigated to ascertain the optimal DG allocation and sizing to improve voltage profile as the main factor for power quality improvement and reducing power losses of the distribution network. Also, from 50% to 150%, the network load is changed to make the investigation more practical BBO has the advantages of both well known algorithms GA and PSO. Sharing information between solutions is one of the GA's features. In PSO, from each iteration to the next, solutions are saved but each saved solution is capable to learn from its neighbors and simultaneously with the progression of the algorithm, adopt itself [25]. so containing these features simultaneously, causes the superior performance of BBO algorithm.

In this paper with a penalty function which entails two penalties with flexible impacts, in each load level four specific buses are selected as the candidates. A penalty for gaining more loss reduction and the other one for obtaining better voltage profile, have been considered. With this strategy without the penetration of voltage profile as an independent objective in main objective function, the appropriate voltage profile is accessible. This technique helps the algorithms to perform more effective search and in each iteration find the best buses to instal DG and also the convergence speed of the algorithms would be increased. But this method needs some algorithms which search for the solutions in binary manner, so with some heuristic approaches like PSO, this technique could not be implemented. Therefore in this investigation the PSO technique which compared with BBO approach is the combination of PSO and BPSO (binary PSO algorithm) named here after as HPSO (hybrid PSO). As mentioned before, because of having the features of PSO and GA, BBO is capable to search in binary way and does not need to be modified like PSO and this is one of the main advantages of this approach. To clarify the efficiency of the presented approach, the results are compared with analytical approach and HPSO algorithm. All the simulations are carried out in MATLAB software. The rest of the paper is organized as follows: section 2 highlights DG types and problem formulation. Section 3 represents the proposed BBO algorithm for optimal DG sitting and sizing. The simulation results are illustrated and discussed in section 4 and finally concluding remarks are drawn in section 5.

## 2. Problem Formulation

### 2.1. Types of a DG

Based on DG units terminal characteristics in terms of active and reactive power delivering capability, those can be categorized into three major types as follows [26]:

- 1) Type 1: This type of DG has capability of injecting only P, such as fuel cells, photovoltaic systems and micro turbines. This type of DG unit is maximized their MWh benefit, From DNOs point of view. However, it may cause reduction in voltage support with respect to distribution system characteristics in providing the needed reactive power [27].
- 2) Type 2: This type of DG has capability of injecting both P and Q. This group of DG units includes synchronous machine and VSC based DG units. For instance, adjusting the power angle and modulation index in VSI-based PV array can be resulted in controlling the output active and reactive power independently [28].
- 3) Type 3: This type of DG have capability of injecting P but usually absorbing Q, such as induction generators utilized in wind farms.

### 2.2. Power Flow Method

Due to several advantages of the forward/backward sweep technique such as. Needing low memory, high computational performance, simple structure, high convergence capability, and applicability to utilization in unbalanced systems, this power flow method has been selected in this study [29-31].

### 2.3. Objective Function

In this study, the objective function is described for real power losses minimization:

$$\text{Objective Function} = \min \{P_L\} \quad (1)$$

Which the exact real power losses are obtained by the following equation:

$$P_L = \sum_{i=1}^{N_b} \sum_{j=1}^{N_b} [a_{ij}(P_i P_j + Q_i Q_j) + b_{ij}(Q_i P_j - Q_j P_i)] \quad (2)$$

Where,

$$a_{ij} = \frac{R_{ij}}{V_i V_j} \cos(\delta_i - \delta_j) \quad \text{And} \quad b_{ij} = \frac{X_{ij}}{V_i V_j} \sin(\delta_i - \delta_j)$$

$Z_{ij} = R_{ij} + jX_{ij}$  are the components of impedance matrix and  $N_b$  is the number of buses [32].

## 2.4. Constrains

The operating restrictions are described as follows:

### 1) The Limitation of Voltage

$$V_{\min} \leq V_i \leq V_{\max} \quad (3)$$

Where  $V_{\min}$  and  $V_{\max}$  indicate the minimum and maximum permissible voltage ( $\pm 5\%$ ) and  $V_i$  is the voltage at bus  $i$ .

### 2) Power balance constraints

$$\sum_{g=1}^{N_g} P_{g_{w/DG}} + \sum_{d=1}^{N_{DG}} P_{g_d} = P_d + P_L \quad (4)$$

Where  $N_g$  and  $N_{DG}$  are the whole number of traditional generation unit and whole number of DGs,  $P_{g_{w/DG}}$  is the amount of active power of traditional power generation unit  $g$  with introducing of DG,  $P_{g_d}$  is the amount of active power of DG unit  $d$ ,  $P_d$  is the whole load demand and  $P_L$  is the whole loss of active power.

### 3) Active and reactive power constraints [33]:

$$P_{gi}^2 + Q_{gi}^2 \leq S_{gi,max}^2 \quad (5)$$

Where  $Q_{gi}$  and  $S_{gi,max}$  represents the amounts of reactive and apparent power of the  $i$ th DG.

## 3. Biogeography Theory

Biogeography Based Optimization (BBO) method which is based on biogeography theory, has been proposed in 2008 by Dan Simon [34]. The procedure of BBO is an example of natural process that can be utilized to solve general problems of optimization. In BBO, each individual is assumed as an island (or a habitat), and the features subscription thorough individuals are depicted as emigration and immigration (Figure 1). Each solution property is named a suitability index variable (SIV). Geographical regions that are appropriated as residences for biological types are said to have a high habitat suitability index (HSI). The meaning of a high HSI of a habitats is proper performance on the optimization problem whereas a low HSI shows improper performance on the optimization problem. Heuristic algorithms solve the optimization problem using Intensification the population. In BBO generating next generation performed by immigrating solution properties to the other islands, and giving solution properties by emigration from the other islands. Then mutation is done for all the population. This mutation procedure is similar to GA algorithm's mutation.

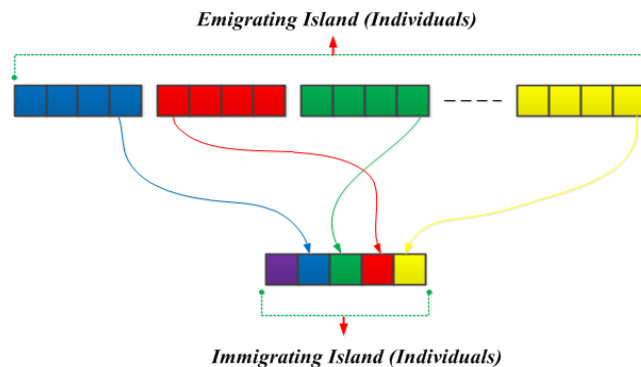

Figure 1. Emmigration of species and new island

In BBO, each individual has its own immigration rate, depicted by  $\lambda$ , and emigration rate, depicted by  $\mu$ . A proper solution has higher  $\mu$ ; Therefore, it has a very high probability of borrowing properties from other solutions, helping it to improve for the next generation illustrated in Figure 2.

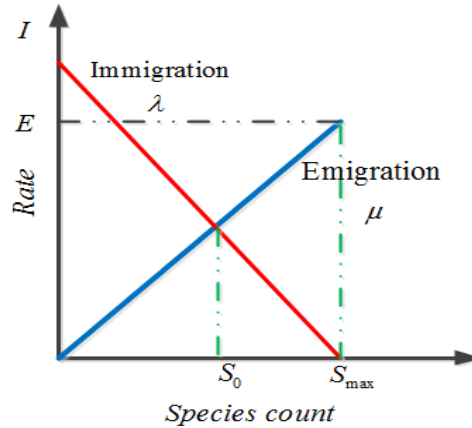

Figure 2. Species model of a single habitat

The fact that in BBO, emigration does not express that the emigrating island loses a property should be considered. Emigration and immigration can be mathematically investigated by a probabilistic model. In addition assume that, consider the probability  $P_s$  that the habitat includes exactly  $S$  species at  $t$ . varies from time  $t$  to time  $t + \Delta t$  as follows:

$$P_s(t + \Delta t) = P_s(t)(1 - \lambda_s \Delta t - \mu_s \Delta t) + P_{s+1} \lambda_{s+1} \Delta t + P_{s-1} \mu_{s-1} \Delta t \quad (6)$$

If  $\Delta t \rightarrow 0$ , from Equation (6) it can be written as follows:

$$\dot{P} = \begin{cases} -(\lambda_s + \mu_s)P_s + \mu_{s+1}P_{s+1}, & S = 0 \\ -(\lambda_s + \mu_s)P_s + \lambda_{s-1}P_{s-1} + \mu_{s+1}P_{s+1}, & 1 \leq S \leq S_{\max} - 1 \\ -(\lambda_s + \mu_s)P_s + \lambda_{s-1}P_{s-1}, & S = S_{\max} \end{cases} \quad (7)$$

Figure 1 illustrates these relationships, as straight lines but, generally, they might be more complicated graphs. The amounts of emigration and immigration rates are obtained as:

$$\mu_k = \frac{Ek}{n} \quad (8)$$

$$\lambda_k = I \left( 1 - \frac{k}{n} \right) \quad (9)$$

Where the maximum possible immigration rate is  $I$ ; the maximum possible emigration rate is  $E$ ;  $K$  is the number of kinds of the  $k$ -th individual and  $n$  is the number of kinds. Now, assume the certain case  $E=I$  (Figure 3). In this case:

$$\lambda_k + \mu_k = E \quad (10)$$

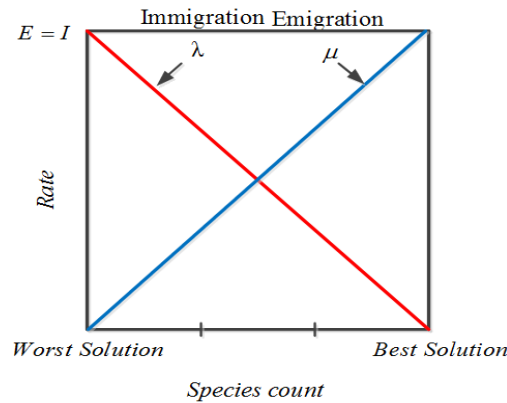

Figure 3. Illustration of two candidate solutions to some problem

**3.1. Biogeography-Based Optimization**

Assume that there is a problem and a population of candidate solutions that are ascertained as vectors. In addition suppose that there are some ways of determining the efficiency of the solutions. Proper solutions are similar to islands with a high island suitability index (ISI), and improper solutions are similar to islands with a low ISI.

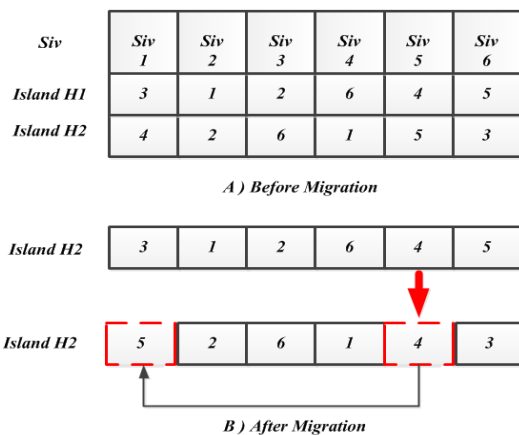

Figure 4. The migration operator in BBO

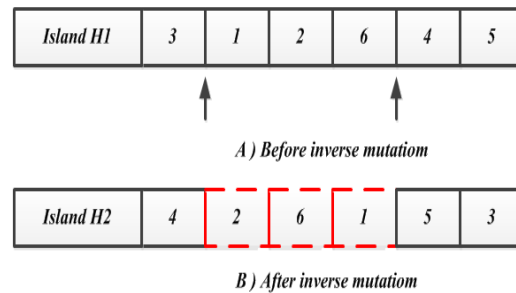

Figure 5. The mutation operator in BBO

Consider that ISI is like “fitness” in other optimization algorithms which are based on population. BBO specially works based on the two structures, migration and mutation as showed in Figures 4, 5.

**3.1.1. Migration**

With probability  $P_{mod}$  which is called habitat modification probability, each solution can be corrected based on other solutions. If a given solution  $S_i$  is chosen to be corrected, then its immigration rate  $\lambda$  is performed to probabilistically decide whether or not to correct each suitability index variable (SIV) in that solution. After choosing the SIV for correction, the rates of emigration  $\mu$  of other solutions are utilized to choose which solutions through the population group will migrate randomly selected SIVs to the chosen solution  $S_i$ .

**3.1.2. Mutation**

In BBO, utilizing the species count probabilities, the mutation rates are determined. As remarked in Equation (7), the probabilities of each species count can be evaluated using the

differential equation. Each member of population has a related probability, which determines the probability that it exists as a solution for a given problem. If the likelihood of a certain solution is very low then that solution similar to mutate to some other solution. Likewise if the some other solution probability is greater then that solution set has very small chance to mutate. Mutation rate of each set of solution can be computed in terms of kinds count probability utilizing the expression:

$$m(S) = m_{max} \left( \frac{1 - P_s}{P_{max}} \right) \quad (11)$$

Where  $m_{max}$  is a user defined parameter.

### 3.2. Proposed Method Steps

This study proposed a new approach based on BBO algorithm which is investigated to determine the optimal location and capacity of different types DGs which is applied to improve voltage profile as the main factor for power quality improvement and reduce power losses of the distribution network. Also in this investigation from 50% to 150%, the system load is changed to make the investigation more practical. With defining two penalty functions related to voltage profile and power loss reduction, searching procedure of proposed algorithm has become more fast and effective. The proposed algorithm steps are performed as follow:

Step 1: Enter the load data of the network and run power flow for each steps of load. Change the loads of the network as follows:

$$P_{L_{i,new}} + jQ_{L_{i,new}} = a(P_{L_i} + jQ_{L_i}) \quad (12)$$

$$a = 0.5, i = 1, \dots, N$$

Where  $a$  is the load coefficient, which varies between 0.5 and 1.5.

- Step 2: Initialize a sample population and DG parameters and define penalty functions in order to obtaining the best voltage profile and more loss reduction, simultaneously.
- Step 3: Detect four best buses for DG installation considering penalty functions, in each load step.
- Step 4: Initialize the BBO parameters including maximum species count, maximum migration rates, and maximum mutation rate and elitism parameter.
- Step 5: Initialize habitats depending upon habitat size within feasible region. Set the iteration counter  $m = 0$ .
- Step 6: Add the counter by 1. Check whether it is less than the maximum iteration limit. If not, print the output results.
- Step 7: If not, calculate the HSI value for the given  $\mu$  &  $\lambda$  and Select the optimum HSI value based on elitism parameters.
- Step 8: Modify each non-elite habitat using immigration & emigration rate.
- Step 9: Check for conceivability. If yes, HSI is computed.
- Step 10: Species count probability is updated and recalculated the HSI.
- Step 11: Go to step 6 for the next iteration. This procedure can be finished after a conceivable problem solution has been found.

The above mentioned method should be repeated for all loading levels (1% load variations). The following BBO parameters have been used, population size=20, Habitat Modification Probability=1, Immigration Probability bounds per gene= [0, 1], elitism parameter = 4, step size for numerical integration of probabilities=1, maximum  $\lambda$  and  $\mu$  rates for each island=1 and Mutation Probability=0.05

## 4. Simulation Results and Discussion

In order to investigate the performance of the proposed approach, the IEEE 33-bus radial distribution test system is utilized in this paper.

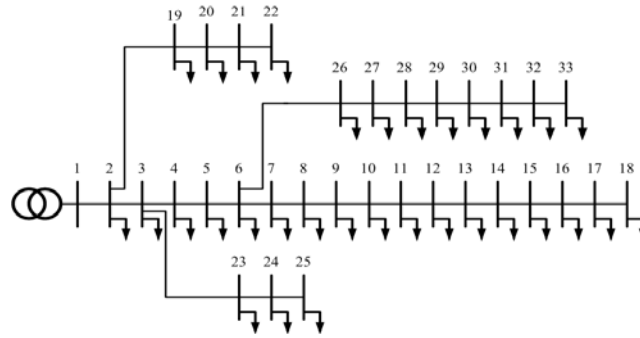

Figure 6. Single line diagram of 33-bus distribution test system

Figure 6 shows the single line diagram of the test system. The total amounts of the active and reactive loads of the system are 3.715 MW and 2.3 MVar, respectively. In addition, as mentioned in [35], the initial amount of the active and reactive power losses before DG allocation are 210.84 kW and 143.114 kVar, respectively. As mentioned before, there are three types of DGs. In this investigation the first two types are discussed. In the first case study, without installation any type of DG units, the system loads are varied linearly from 50% to 150% of base case with 1% steps. In the second case and third case the DG type 1 and type 2 are investigated respectively.

#### 4.1. Without using DG

The results of simulation test for variation in losses and minimum value of voltage are obtained for three distinct conditions: base load values, increased by 50% and decreased by 50% are mentioned in Table 1.

Table 1. Results of Variations (Without Using DGs)

IEEE 33	Decrease 50%	Base case	Increase 50%
$P_{\text{loss}}$ (kW)	48.7566	210.84	519.3936
$Q_{\text{loss}}$ (kVar)	33.0471	143.114	353.1554
$V_{\text{min}}(\text{pu})@_{\text{bus}}$	0.9540@18	0.9039@18	0.8483@18

The 50 % increase in load values has led to worst voltage profile. The minimum voltage in this condition is experienced at bus 18 which is equal to 0.8483. On the other hand, after 50% enhancement in load values, the voltage profile is increased and the minimum voltage level is at bus 18 with the value of 0.9540. As shown in Figure 7, load increase causes a negative effect on the voltage profile. On the other hand, because of increment in the load, the voltage profile is enhanced. Once the load is decreased, a reduction in the slope of the loss curve could be seen, as well.

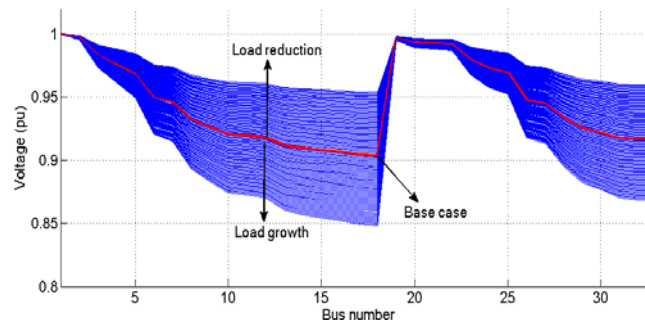

Figure 7. illustrates the voltage profile under distinct load conditions

For example, when the load is enhanced about 50% of its base value, the active and reactive power losses are reduced by 145.36–145.86%, respectively. Nevertheless, as the load is decreased by 50% of its base value, the active and reactive power losses are reduced by 76.67–79.71%, respectively. Figure 8 illustrates the amounts of the active and reactive power losses under distinct loading conditions.

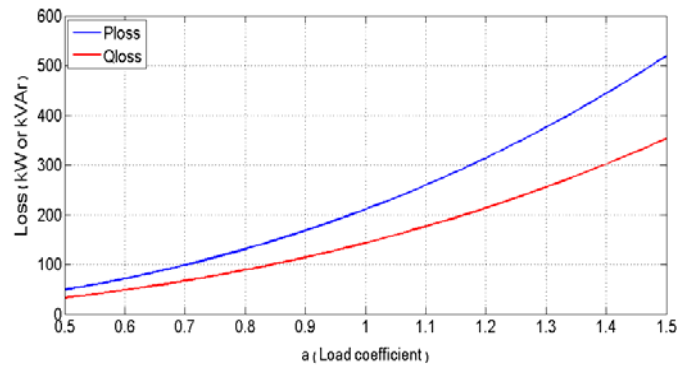

Figure 8. Loss variations under different loading levels (without installing DG)

#### 4.2. Installation of type1-DG

In this case, the optimal placement and size of the single DG unit, which is scheduled to provide only active power (P), are evaluated. To make it comparable with the results of last subsection, the feeder loads are changed in the same way.

After various simulations in diverse conditions including load changing, some notable points have been carried out which are as follow:

1) Four buses are chosen to instal the DG. This selection is based on having proper voltage profile and more reduction in power losses simultaneously. The four choices as best bus candidates are 6, 7, 26, and 27.

2) With regard to voltage profile and voltage stability indices, the best bus for DG installation is 7, while with considering on power loss reduction, the proper bus to instal the DG is 6. But in this paper the focus on loss reduction is more than voltage profile so finally the best bus to instal DG is 6. The numerical results which proved the above mentioned points are shown in Table 2. This point also for installation of type-2 DG is true but in order to avoid repetition, in this investigation only the results of type-1 DG placement in the two bus candidates are expressed and compared.

Table 2. Comparison of DG Installation With the Same Size on Bus 6, 7 Under Load Variation Resulted By BBO Algorithm

IEEE 33	$P_{loss}$ (kW) (bus 6)	$P_{loss}$ (kW) (bus 7)	$Q_{loss}$ (kVAr) (bus 6)	$Q_{loss}$ (kVAr) (bus 7)	Vmin(pu)@bus (bus 6)	Vmin(pu)@bus (bus 7)
Load Decrease by 50%	26.4559	26.9239	19.459	20.7015	0.9719@18	0.9739@18
Base Case	110.834	111.90	81.693	84.6439	0.9425@18	0.9448@18
Load Increase by 50%	261.187	264.04	192.573	199.50	0.9122@18	0.9170@18

Figure 9 demonstrates the optimal size of the DG unit assessed by HPSO method, Analytical approach [26] and proposed BBO approach. As shown in Figure 9, the optimal size of the DG unit varies linearly by the changing in the feeder load.



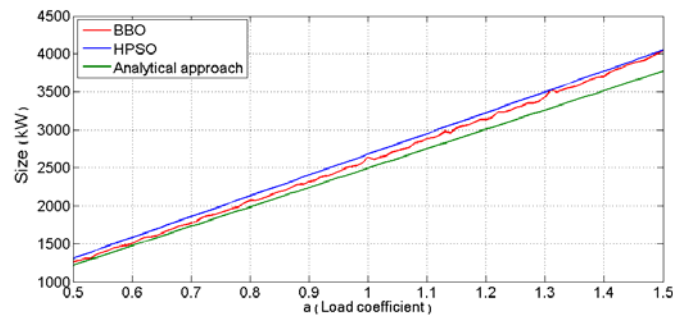

Figure 9. Optimal size of type1-DG unit under different loading levels

The load flow analysis demonstrates that the percentage of loss reduction in the BBO-based approach is slightly greater than that of the PSO method and analytical approach.

In Table 3, the results of the proposed approach for three states of loads are given and also compared with the obtained results of HPSO algorithm and Analytical approach in the same condition.

Table 3. Comparison Results of the Load Changing in Presence of Type1-DG, Evaluated by HPSO Algorithm, Analytical Approach and Proposed BBO Approach

IEEE 33	Decrease 50%	Base case	Increase 50%
HPSO algorithm	$P_{loss}$ (kW)=26.4561 $Q_{loss}$ (kVAr)= 19.487 $V_{min}(pu)@bus=0.9718@18$ DG Size= 1331 kW	$P_{loss}$ (kW)=111.030 $Q_{loss}$ (kVAr)= 81.911 $V_{min}(pu)@bus=0.9424@18$ DG Size=2712 kW	$P_{loss}$ (kW)=262.315 $Q_{loss}$ (kVAr)= 192.921 $V_{min}(pu)@bus=0.9121@18$ DG Size=4016 kW
Analytical approach	$P_{loss}$ (kW)=27.632 $Q_{loss}$ (kVAr)= 20.332 $V_{min}(pu)@bus=0.9712@18$ DG Size= 1235 kW	$P_{loss}$ (kW)=111.921 $Q_{loss}$ (kVAr)= 82.321 $V_{min}(pu)@bus=0.9719@18$ DG Size= 2501 kW	$P_{loss}$ (kW)=268.214 $Q_{loss}$ (kVAr)= 196.018 $V_{min}(pu)@bus=0.9703@18$ DG Size= 3785 kW
Proposed BBO approach	$P_{loss}$ (kW)=26.4559 $Q_{loss}$ (kVAr)= 19.459 $V_{min}(pu)@bus=0.9719@18$ DG Size= 1272kW	$P_{loss}$ (kW)=110.834 $Q_{loss}$ (kVAr)= 81.693 $V_{min}(pu)@bus=0.9425@18$ DG Size= 2598 kW	$P_{loss}$ (kW)=261.187 $Q_{loss}$ (kVAr)= 192.573 $V_{min}(pu)@bus=0.912@18$ DG Size= 4012 kW

Figure 10 demonstrates the voltage profile under different loading levels. According to the results of Figure 7 and Figure 10, it can be noted that application of DG in the system has amended the voltage profile effectively.

In the load growth case, the minimum voltage magnitude has occurred at bus 18, which is 0.9122 pu. For 50% load increase. On the other side, as the load is reduced, the minimum voltage magnitude is 0.9719 pu. at bus 18 for a 50% decrease.

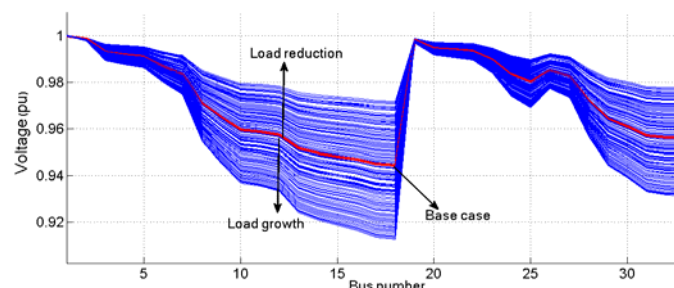

Figure 10. Voltage profile under different loading levels after installation of type1-DG (by BBO approach)

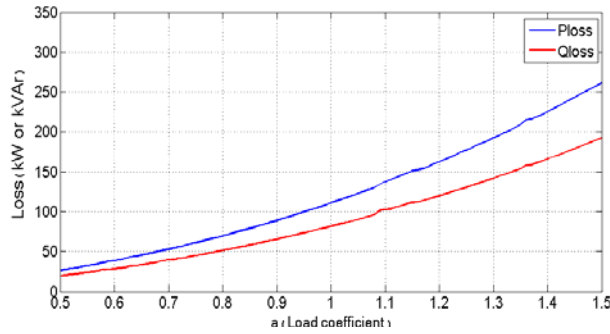

Figure 11. Loss variations under different loading levels after installation of type1-DG

Figure 11 illustrates the active and reactive power losses under different conditions after establishment of type1-DG and utilizing the biogeography based optimization (BBO) algorithm.

According to the results of Figure 8 and Figure 11, it can be noted that the active and reactive power losses are detracted for all load levels after installation of type1-DG. The values of active and reactive power losses are reduced by 49.25– 44.83%, respectively. In the case of 50% reduction in the load, the active and reactive power losses are decreased by 45.5–40.82%, respectively.

**4.3. Installation of type2-DG**

In this case, the DG unit can produce both P and Q. The results of three different loading condition in the presence of type2-DG unit and resulted by BBO approach are given in Table 4 and also compared with the obtained results of HPSO algorithm and Analytical approach in the same condition.

Table 4. Comparison Results of the Load Changing in Presence of Type2-DG, Evaluated by HPSO Algorithm, Analytical Approach and Proposed BBO Approach

IEEE 33	Decrease 50%	Base case	Increase 50%
HPSO algorithm	$P_{loss}$ (kW)=16.4438	$P_{loss}$ (kW)=65.9382	$P_{loss}$ (kW)=156.2214
	$Q_{loss}$ (kVAr)=13.0303	$Q_{loss}$ (kVAr)= 53.2140	$Q_{loss}$ (kVAr)= 126.1621
	Vmin(pu)@bus=0.9719@18 DG Size= 1496 KVA	Vmin(pu)@bus=0.9588@18 DG Size= 3137 KVA	Vmin(pu)@bus=0.9345@18 DG Size= 4778 KVA
Analytical approach	$P_{loss}$ (kW)=16.2123	$P_{loss}$ (kW)=66.3321	$P_{loss}$ (kW)=157.1235
	$Q_{loss}$ (kVAr)= 12.6303	$Q_{loss}$ (kVAr)= 53.8721	$Q_{loss}$ (kVAr)= 126.754
	Vmin(pu)@bus=0.9719@18 DG Size= 1482 KVA	Vmin(pu)@bus=0.9573@18 DG Size= 3040 KVA	Vmin(pu)@bus=0.9341@18 DG Size= 4599 KVA
Proposed BBO approach	$P_{loss}$ (kW)=16.5433	$P_{loss}$ (kW)=67.9448	$P_{loss}$ (kW)=157.4616
	$Q_{loss}$ (kVAr)= 13.3303	$Q_{loss}$ (kVAr)= 54.8304	$Q_{loss}$ (kVAr)= 127.1075
	Vmin(pu)@bus=0.9785@18 DG Size= 1334 KVA	Vmin(pu)@bus=0.9568@18 DG Size= 2925 KVA	Vmin(pu)@bus=0.9340@18 DG Size= 4587 KVA

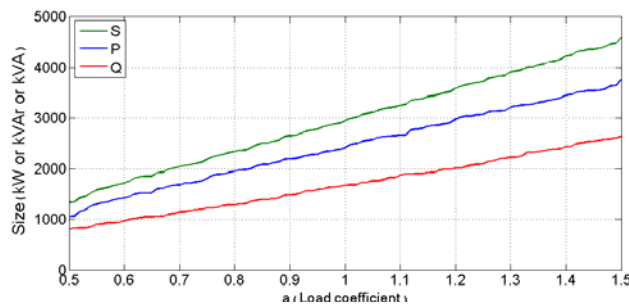

Figure 12. Optimal size of type2-DG unit under different loading levels

The result of the simulation test represents that the optimal placement of type-2 DG is at bus 6 for different loading levels. Figure 12 illustrates that the optimal size of the DG unit varies linearly by the changing in the feeder load assessed by BBO based approach.

Figure 13 depicts optimal size of type-2 DG installation determined by HPSO method, Analytical approach and proposed BBO approach. The results in this case show the better performance of proposed BBO approach in comparison with the other mentioned methods.

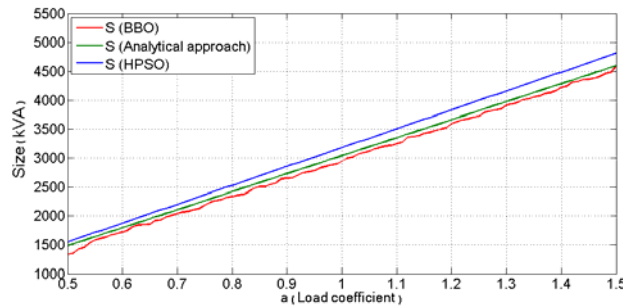

Figure 13. Optimal size of type2-DG unit under different loading levels determined by three approaches

The superior performance of proposed BBO method is because not only the values of minimum voltage profile and power loss is very close in the three methods, but also the DG capacity which is selected by BBO is less than the other two methods and this proper choice is reasonable during the installation of both type-1&2 DG units. When the load is increased exactly by 50% (in comparison with the condition without using DG) the active and reactive losses are reduced by 67.91–62.84%, respectively, while in the condition that the load is decreased exactly by 50%, then the active and reactive losses are reduced by 64.84–58.23%, respectively.

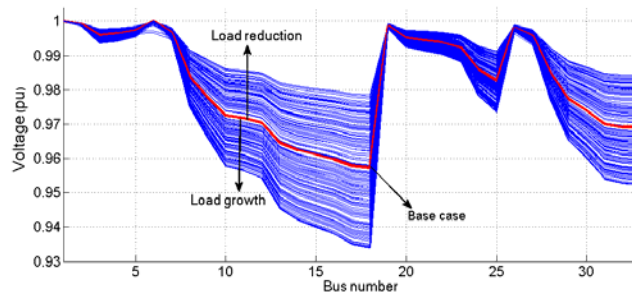

Figure 14. Voltage profile under different loading levels after installation of type2-DG( by BBO approach)

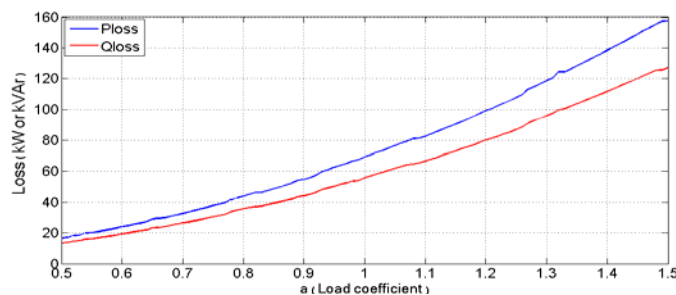

Figure 15. Loss variations under different loading levels after installation of type2-DG( by BBO approach)

Figure 14 illustrates the voltage profile under distinct loading levels. Comparing the results of Figure 7, Figure 10, Figure 14, it can be noted that the installation of the type-2 DG has a significant effect on the voltage profile among all types of DG unit. Figure 15 shows the active and reactive power losses under distinct loading levels at the presence of type-2 DG.

According to the results of Figure 8, Figure 11, Figure 15, it can be noted that active and reactive power losses at each step are detracted and the maximum effect on active and reactive losses can be seen for this type of DG. The total capacity of distributed generation unit in this work is 5 MVA. The amount of power loss reduction in BBO approach is more than PSO and analytical approach and the optimal selection of DG capacity in the BBO approach is noticeable in comparison with the other two methods.

## 5. Conclusion

A novel method based on BBO algorithm for long term scheduling of optimal placement and sizing of different types of DG units was proposed in this paper. The main purposes of this study are loss minimization and voltage profile improvement. Also by using two penalty functions with flexible impacts on voltage profile improvement and loss reduction, the best locations to instal DGs are selected. In this investigation linearly load variation from 50% to 150% is also considered, Therefore the optimal size of DG unit has been changed as load changes. This is a very applicable tool for DNOs that simplify the generation scheduling over the planning horizon. The feasibility and robustness of proposed BBO method is proved by comparing it with analytical approach and HPSO algorithm which is combined typical and binary PSO algorithm. The results illustrated that the application of the DG in the power system would decrease active and reactive power losses effectually while the voltage profile has been also amended. This long term scheduling prepares maximum advantages for DNOs because of optimal operation over the scheduling period. The proposed BBO-based approach is a simple and also comprehensive, which can be used to various mixed integer nonlinear optimization problems in the power systems.

## References

- [1] Chiradeja, Ramakumar. *An approach to quantify the technical benefits of DG*. IEEE Trans Energy Convers. 2007; 19(4).
- [2] Pepermans G, et al. Distributed generation: definition, benefits and issues. *Energy Policy*. 2005; 33: 787-798.
- [3] Wijayatunga PDC, Fernando WJLS, Shrestha RM. *Impact of distributed and independent power generation on greenhouse gas emissions*. J Energy Convers, Manage. Sri Lanka. 2004: 3193-3206.
- [4] Jurado F, Cano A. Optimal placement of biomass fuelled gas turbines for reduced losses. *J Energy Convers Manage*. 2006; 47(15-16): 2673-2681.
- [5] Rao, Gummadi Srinivasa, YP Obulesh. Voltage Profile Improvement of Distribution System using Distributed Generating Units. *International Journal of Electrical and Computer Engineering (IJECE)*. 2013; 3(3): 337-343.
- [6] Pregelj A, Begovic M, Rohatgi A. Recloser allocation for improved reliability of DG-enhanced distribution networks. *IEEE Trans Power Syst*. 2006; 21(3): 1442-1449.
- [7] Mendez VH, Rivier J, Gomez T. Assessment of energy distribution losses for increasing penetration of distributed generation. *IEEE Trans Power Syst*. 2006; 21(2): 533-540.
- [8] Gil HA, Joos G. On the quantification of the network capacity deferral value of distributed generation. *IEEE Trans Power Syst*. 2006; 21(4): 1592-1599.
- [9] Mendez VH, Rivier J, de la Fuente JI, Gomez T, Arceluz J, Marin J, et al. Impact of distributed generation on distribution investment deferral. *Int J Elect Power Energy Syst*. 2006; 28(4): 244-252.
- [10] Triggianese M, Liccardo F, Marino P. *Ancillary services performed by distributed generation in grid integration*. In: Proc 2007 int conf clean electrical power (ICCEP). 2007: 164-170.
- [11] Piccolo Antonio, Siano Pierluigi. Evaluating the impact of network investment deferral on distributed generation expansion. *IEEE Trans Power Syst*. 2009; 24(3): 1592-1599.
- [12] Wang C, Nehrir MH. Analytical approaches for optimal placement of distributed generation sources in power systems. *IEEE Trans Power Syst*. 2004; 19(4): 2068-2076.
- [13] Ochoa LF, Padilha-Feltrin A, Harrison GP. Evaluating distributed generation impacts with a multi-objective index. *IEEE Trans Power Delivery*. 2006; 21(3): 1452-1458.
- [14] Abou El-Ela AA, Spea SR. Optimal corrective actions for power systems using multi-objective genetic algorithms. *J Electr Power Syst*. 2009; 79: 722-733.

- [15] Abou El-Ela AA, Aly GEM, Shammah AE. Multi-objective optimal planning and operation of distribution system using genetic algorithms. *Int. Energy J.* 2007; 8: 291-300.
- [16] Jamian JJ, MW Mustafa, H Mokhlis, MA Baharudin. A new particle swarm optimization technique in optimizing size of distributed generation. *International Journal of Electrical and Computer Engineering (IJECE)*. 2012; 2(1): 137-146.
- [17] Gandomkar M, Vakilian M, Ehsan M. A combination of genetic algorithm and simulated annealing for optimal DG allocation in distribution networks. In: 2005 Canadian conference on electrical and, computer engineering. 2005: 645–648.
- [18] Moradi MH, Abedini M. A combination of genetic algorithm and particle swarm optimization for optimal DG location and sizing in distribution systems. *Int J Electr Power Energy Syst.* 2012; 34(1): 66-74.
- [19] Nara K, Hayashi Y, Ikeda K, Ashizawa T. Application of tabu search to optimal placement of distributed generators. In: IEEE power engineering society winter meeting. 2001: 918–923.
- [20] Le DT, Kashem MA, Negnevitsky M, Ledwich G. Optimal distributed generation parameters for reducing losses with economic consideration. In: IEEE general meeting. 2007: 1-8.
- [21] Khalesi N, Rezaei N, Haghifam M-R. DG allocation with application of dynamic programming for loss reduction and reliability improvement. *Int. J. Electr. Power Energy Syst.* 2011; 33(2): 288-295.
- [22] Arya LD, Koshti Atul, Choube SC. Distributed generation planning using differential evolution accounting voltage stability consideration. *Int J Electr Power Energy Syst.* 2012; 42(1): 196-207.
- [23] Abu-Mouti FS, El-Hawary ME. Optimal distributed generation allocation and sizing in distribution systems via artificial bee colony algorithm. *IEEE Trans Power Deliv.* 2011; 26(4): 2090-2101.
- [24] Rao RS, Ravindra K, Satish K, Narasimham SVL. Power loss minimization in distribution system using network reconfiguration in the presence of distributed generation. *IEEE Trans Power Syst.* 2013; 28: 317-325.
- [25] Roy PK, SP Ghoshal, SS Thakur. Optimal VAR control for improvements in voltage profiles and for real power loss minimization using biogeography based optimization. *International Journal of Electrical Power & Energy Systems.* 2012; 43(1): 830-838.
- [26] Hung DQ, Mithulananthan N, Bansal RC. Analytical expressions for DG allocation in primary distribution networks. *IEEE Trans Energy Convers.* 2010; 25(3): 814-620.
- [27] Ochoa LuisF, Keane A, Harrison GP. Minimizing the reactive support for distributed generation: enhanced passive operation and smart distribution networks. *IEEE Trans Power Syst.* 2011; 26(4): 2134-2142.
- [28] Zou K, Agalgaonkar AP, Muttaqi KM, Perera Sarath. Distribution system planning with incorporating DG reactive capability and system uncertainties. *IEEE Trans Syst Energy.* 2012; 3(1): 112-123.
- [29] Eminoglu U, Hocaoglu MH. A new power flow method for radial distribution systems including voltage dependent load models. *Elect Power Syst Res.* 2005; 76(1-3): 106-14.
- [30] Expósito AG, Ramos ER. Reliable load flow technique.
- [31] Farag HE, El-Saadany EF, El Shatshat R, Zidan A. A generalized power flow analysis for distribution systems with high penetration of distributed generation. *Electr Power Syst Res.* 2011; 81(7): 1499-1506.
- [32] Kothari DP, Dhillon JS. Power system optimization. New Delhi: Prentice-Hall. 2006: 180-185.
- [33] Teng JH. Modelling distributed generations in three-phase distribution load flow. *IET Gen Trans Distrib.* 2008; 2: 330-340.
- [34] Simon D. Biogeography-based optimization. *IEEE Trans Evolut Comput.* 2008; 12(6): 702-713.
- [35] Baran ME, Wu FF. Optimal sizing of capacitor placed on radial distribution systems. *IEEE Trans Power Deliv.* 1989; 4(1): 735-743