

# The Feasibility Study of Using Space Vector Modulation Inverters in Two-Level of Integrated Photovoltaic System

Mahmoud Zadehbagheri\*, Amin Payedar

Faculty of Engineering, Department of Electrical, Yasouj Branch, Islamic Azad University,  
Kohgiluyeh & Bovirahmad Province, Yasouj, Iran

\*Corresponding author, e-mail: Mzadehbagheri@gmail.com

## Abstract

*In this paper a system of integrated photovoltaic converter with vector switching control inverter with the modulation method of spatial two-level has been presented. The structure of the system is presented with the proposed and the structure of the invertors' voltage source has been reviewed. Space vector modulation control method of two-level in a voltage source inverter and then provide proposed system analysis and keying modes are analyzed and the system designing and with the simulation of MATLAB software and standards of the total harmonic distortion for a few modulation methods for comparison, and evaluation has been proposed. The system has been analyzed in terms of economic. A prototype for assessing and comparing with power of 360w in the output with DC link voltage is 400 V and the module voltage is 46.5v has an efficiency of 97.9% in its output that improved than SPWM of 1.6% and to the PWM of 2.7% and Has been simulated with MATLAB software and compared to with a few examples of the control systems of the sinusoidal pulse width modulation and pulse width modulation. Speed and Switching and performance of the system have been analyzed and methods to reduce switching losses and increase of the system efficiency in the practical examples are proposed.*

**Keywords:** photovoltaic systems, voltage source inverter, space vector modulation, multilevel inverter, efficiency

**Copyright © 2015 Institute of Advanced Engineering and Science. All rights reserved.**

## 1. Introduction

The system which utilizes solar energy without moving mechanism and chemical energy into electrical energy, its effect is called the photovoltaic [1], development and use of photovoltaic systems to provide electrical energy needed so that in some places and uses the best option for providing electrical energy is applied, As a result of technological advances in the use of solar energy through photovoltaic systems predict that the energy cost of \$ 5 kWh kilowatt-hour in 1990 to \$ 0.8 in 2020 to 0.5 reduced, this type of energy can be supplied to the national grid energy needs of societies that do not have access to finance [2], and due to the increasing prices of fossil fuels and other energy sources, optimization and cost-effective use of photovoltaic systems integrated with proper design is essential. Economic factors play an important role in the design of photovoltaic systems and have a strong economic factors such as the fixed cost and variable cost be measured at the design exactly. Almost 60% of the cost of a photovoltaic system is a constant related to the purchase is the second module , because of the short duration of benefits such as integrated photovoltaic systems design and installation, quiet, energy conversion process, the high life and require little maintenance due to no moving parts, easy to transport the lightweight components, and lack of contamination environmental development, progress and public acceptance [2], Integrated photovoltaic system components include modules, voltage regulators and controllers (inverters and converters) and storage systems such as batteries. The inverter module contributes to the fixed costs are allocated and for all its production costs, in recent years much effort has been designed to reduce the cost and at the same time raise the efficiency of their work is done. Each module (PV) · inverter(DC-AC) of Photovoltaic integrated converter system has role of the function maximum power point tracking [3]. Commercialization of the system, with low price and high efficiency power transfer plan should be for the electric power transmission network with a high power factor will develop

[4], that in these systems to adjust the voltage level of the converter module become increasingly common as a boost converter, a voltage level converters are increasingly used [14-15]. Provided converts that is a switch direction current converter (DC-DC) for converting the DC voltage to the input unregulated voltage output controlled with an optimal amount of work [5], provided inverter that the converts DC voltage to a transducer type (direct current) voltage alternating current (AC) voltage source different methods to control the space vector pulse width modulation method here (SVPWM) the two-level has been used Space vector pulse width modulation(SVPWM). Figure 1 Overview of a sample of integrated photovoltaic grid-connected inverter system is shown.

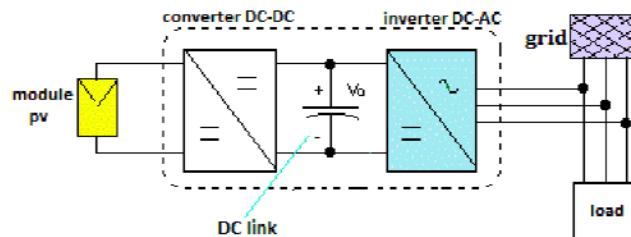

Figure 1. Overview of a photovoltaic system integrated transducers

## 2. Voltage Source Inverter

Voltage source inverter, a constant voltage to a three-phase alternating voltage with adjustable amplitude and frequency turns [6], the frequency of the output voltage can be fixed or variable, constant or variable. The output voltage can be achieved by changing the input voltage (DC) and gain inverter maintains interest. If the DC input voltage is not constant and can be controlled by changing a variable voltage output of the inverter will be obtained that this operation is usually controlled by pulse width modulation and its variants are done. Benefit ratio of the output voltage to the input of the converter can be defined. The voltage source inverter power switches fast as the average power and low-power insulated gate bipolar transistors (IGBTs) and metal-oxide-semiconductor field effect transistors (MOSFETs) and etc are used. The voltage source inverter for photovoltaic module system integrated two-level (PVMIC) to 6 switching required (S1-S6) that any key (switch), a freewheeling diode in parallel has been reversed. Depending on the size of constant voltage inverter switches can group two or more than two switching elements which are sequentially formed [13-14].

## 3. Space Vector Modulation

The inverter operates with voltage control and frequency of the applied pulse modulation pulse pattern of switches (switch) is done inverter. Space vector modulation (SVM), one of the preferred methods for simultaneous modulation or real-time is widely used to control the voltage source inverter [7-8]. Its main characteristic switching times less per cycle and therefore lower switching losses. Sinusoidal pulse width modulation and pulse width modulation technique in [5-6] have been discussed in detail and the results are given only the description is ignored. Assume a two-level three-phase inverter is fed by Figure 2, most frequently because the resistive - inductive (inductive effect), we have to model inductive load [9].

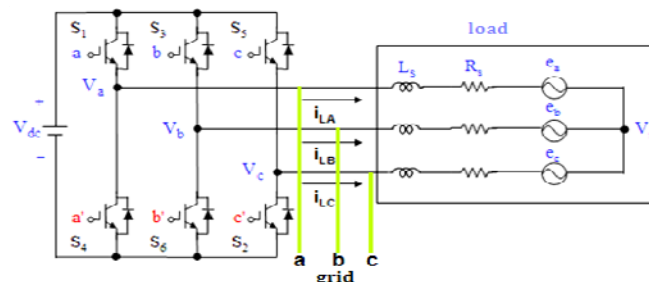

Figure 2. Circuit model of a three-phase voltage source inverter

4. Switching Modes

2<sup>3</sup> switching modes switches for high and low there. Dihedral inverter switching functions in Figure 2 are shown in Table 1.

Tabel 1. Mode switching

Switching	Leg A			Leg B			Leg C		
state	S1	S4	Vao	S3	S6	Vbo	S5	S2	Vco
1	On	Off	Vd	On	Off	Vd	On	Off	Vd
0	Off	On	0	Off	On	0	Off	On	0

The space vector modulation switching key sequences can be considered high or low, in this paper we consider the low-frequency switching switches is shown in Figure 3.

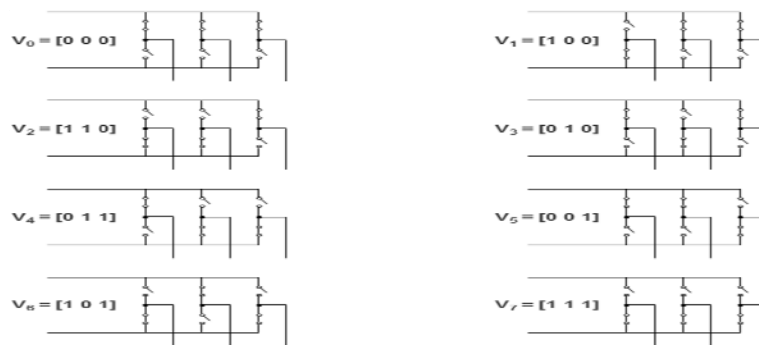

Figure 3. The switching frequency of the lower switch

From Figure 3, we have eight voltage vectors (V0~V7). Phase vectors and line for eight switching mode is shown in Table 2 should be multiplied by the DC link voltage (Vdc).

Table 2. Vectors for the eight-state phase voltage and line

Voltage vectors	Switching vectors			V_ph			V_L_L		
	a	b	c	Van	Vbn	Vcn	Vab	Vbc	Vca
V0	0	0	0	0	0	0	0	0	0
V1	1	0	0	2/3	-1/3	-1/3	1	0	-1
V2	1	1	0	1/3	1/3	-2/3	0	1	-1
V3	0	1	0	-1/3	2/3	-1/3	-1	1	0
V4	0	1	1	-2/3	1/3	1/3	-1	0	1
V5	0	0	1	-1/3	-1/3	2/3	0	-1	1
V6	1	0	1	1/3	-2/3	1/3	1	-1	0
V7	1	1	1	0	0	0	0	0	0

Switching states (000) and (111) to zero states and other states are called active. Figure 4: Diagram of a two-level inverter space vector for the show.

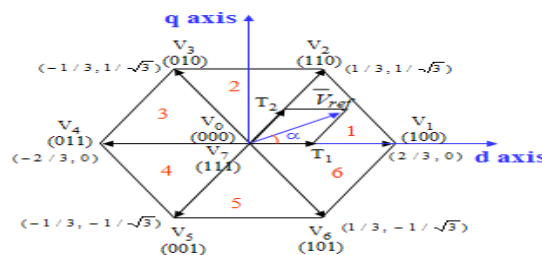

Figure 4. Diagram of a vector space for 2-level inverter

6 non-zero vector (V1-V6) forming a regular six-sided that have been divided into six zones (1 to 6) and two vectors are zero at the center of the six-sided angle between two adjacent vectors is non-zero  $60^\circ$ .

Step 1 - Figure 4 d-q transformation angle calculated  $\alpha$ ,  $V_d$ ,  $V_q$ ,  $V_{ref}$ .

$$\begin{aligned} V_d &= V_{an} - V_{bn} \cdot \cos 60 - V_{cn} \cdot \cos 60 \\ &= V_{an} - \frac{1}{2} V_{bn} - \frac{1}{2} V_{cn} \end{aligned}$$

$$\begin{aligned} V_q &= 0 + V_{bn} \cdot \cos 30 - V_{cn} \cdot \cos 30 \\ &= V_{an} + \frac{\sqrt{3}}{2} V_{bn} - \frac{\sqrt{3}}{2} V_{cn} \end{aligned} \quad (1)$$

$$\begin{bmatrix} V_d \\ V_q \end{bmatrix} = \frac{2}{3} \begin{bmatrix} 1 & -\frac{1}{2} & -\frac{1}{2} \\ 0 & \frac{\sqrt{3}}{2} & -\frac{\sqrt{3}}{2} \end{bmatrix} \begin{bmatrix} V_{an} \\ V_{bn} \\ V_{cn} \end{bmatrix} \quad (2)$$

$$\begin{aligned} |\bar{V}_{ref}| &= \sqrt{V_d^2 + V_q^2} \\ \alpha &= \tan^{-1} \left( \frac{V_q}{V_d} \right) = \omega_s t = 2 \pi f_s t \end{aligned} \quad (3)$$

The base frequency is  $f_s$ . Inverter output frequency depends on the rotation speed  $V_{ref}$  and  $V_{ref}$  output voltage can be adjusted to change the size. In Figure 5,  $V_{ref}$  is obtained by combining two adjacent vectors [10].

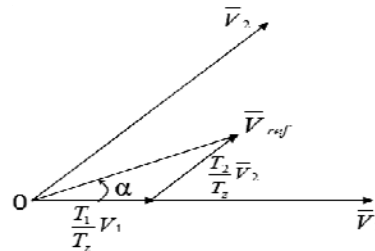

Figure 5. combination of two vectors adjacent to the reference vector part 1

Step 2 - Calculate the length of time  $T_1, T_2, T_0$

For part one, it is had:

$$\begin{aligned} \int_0^{T_z} \bar{V}_{ref} dt &= \int_0^{T_1} \bar{V}_1 dt + \int_{T_1}^{T_1+T_2} \bar{V}_2 dt + \int_{T_1+T_2}^{T_z} \bar{V}_0 dt \\ \therefore T_z \cdot \bar{V}_{ref} &= (T_1 \cdot \bar{V}_1 + T_2 \cdot \bar{V}_2) \\ \Rightarrow T_z \cdot |\bar{V}_{ref}| \begin{bmatrix} \cos(\alpha) \\ \sin(\alpha) \end{bmatrix} &= T_1 \cdot \frac{2}{3} \cdot V_{dc} \cdot \begin{bmatrix} 1 \\ 0 \end{bmatrix} + T_2 \cdot \frac{2}{3} \cdot V_{dc} \cdot \begin{bmatrix} \cos(\pi/3) \\ \sin(\pi/3) \end{bmatrix} \\ & \quad (0 \leq \alpha \leq 60^\circ) \end{aligned} \quad (4)$$

$$T_1 = T_z \cdot a \cdot \frac{\sin(\pi/3 - \alpha)}{\sin(\pi/3)}$$

$$T_2 = T_z \cdot a \cdot \frac{\sin(\alpha)}{\sin(\pi/3)}$$

$$T_0 = T_z - (T_1 + T_2), \quad \left( \text{where, } T_z = \frac{1}{f_s} \text{ and } a = \frac{|\bar{V}_{ref}|}{\frac{2}{3} V_{dc}} \right)$$

For each of the sections:

$$\begin{aligned}
 T_1 &= \frac{\sqrt{3} \cdot T_z \cdot |\bar{V}_{ref}|}{V_{dc}} \left( \sin \left( \frac{\pi}{3} - \alpha + \frac{n-1}{3} \pi \right) \right) \\
 &= \frac{\sqrt{3} \cdot T_z \cdot |\bar{V}_{ref}|}{V_{dc}} \left( \sin \frac{n}{3} \pi - \alpha \right) \\
 &= \frac{\sqrt{3} \cdot T_z \cdot |\bar{V}_{ref}|}{V_{dc}} \left( \sin \frac{n}{3} \pi \cos \alpha - \cos \frac{n}{3} \pi \sin \alpha \right) \\
 T_2 &= \frac{\sqrt{3} \cdot T_z \cdot |\bar{V}_{ref}|}{V_{dc}} \left( \sin \left( \alpha - \frac{n-1}{3} \pi \right) \right) \\
 &= \frac{\sqrt{3} \cdot T_z \cdot |\bar{V}_{ref}|}{V_{dc}} \left( -\cos \alpha \cdot \sin \frac{n-1}{3} \pi + \sin \alpha \cdot \cos \frac{n-1}{3} \pi \right) \\
 T_0 &= T_z - T_1 - T_2, \quad \left( \text{where, } n = 1-6 \right) \\
 &\quad \left( 0 \leq \alpha \leq 60^\circ \right)
 \end{aligned}
 \tag{5}$$

Step 3 - Calculate the switching time for each section (1 to 6) is shown in Figure 5 and Table 3.

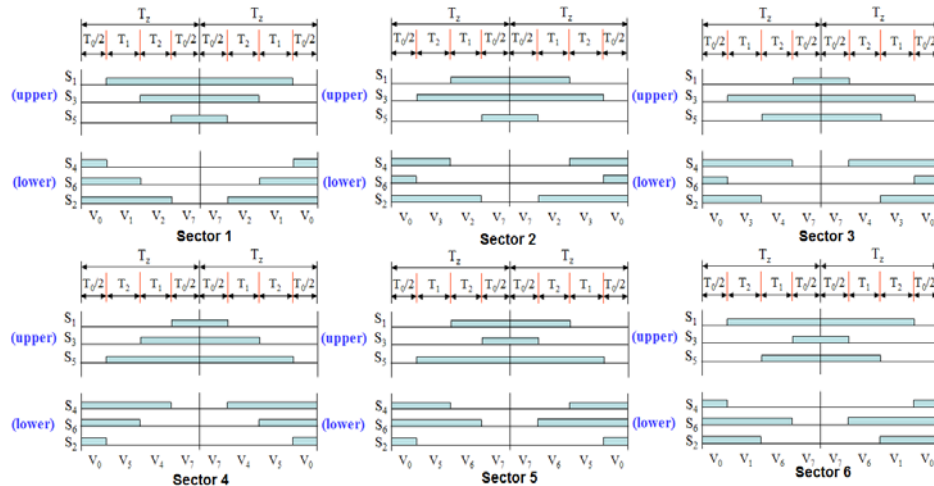

Figure 5. Length of each switching period of six

Table 3. The switching time calculation for each section

Sector	Upper Switches (S <sub>1</sub> , S <sub>3</sub> , S <sub>5</sub> )	Lower Switches (S <sub>4</sub> , S <sub>6</sub> , S <sub>2</sub> )
1	$S_1 = T_1 + T_2 + T_0 / 2$ $S_3 = T_2 + T_0 / 2$ $S_5 = T_0 / 2$	$S_4 = T_0 / 2$ $S_6 = T_1 + T_0 / 2$ $S_2 = T_1 + T_2 + T_0 / 2$
2	$S_1 = T_1 + T_0 / 2$ $S_3 = T_1 + T_2 + T_0 / 2$ $S_5 = T_0 / 2$	$S_4 = T_2 + T_0 / 2$ $S_6 = T_0 / 2$ $S_2 = T_1 + T_2 + T_0 / 2$
3	$S_1 = T_0 / 2$ $S_3 = T_1 + T_2 + T_0 / 2$ $S_5 = T_2 + T_0 / 2$	$S_4 = T_1 + T_2 + T_0 / 2$ $S_6 = T_0 / 2$ $S_2 = T_1 + T_0 / 2$
4	$S_1 = T_0 / 2$ $S_3 = T_1 + T_0 / 2$ $S_5 = T_1 + T_2 + T_0 / 2$	$S_4 = T_1 + T_2 + T_0 / 2$ $S_6 = T_2 + T_0 / 2$ $S_2 = T_0 / 2$
5	$S_1 = T_2 + T_0 / 2$ $S_3 = T_0 / 2$ $S_5 = T_1 + T_2 + T_0 / 2$	$S_4 = T_1 + T_0 / 2$ $S_6 = T_1 + T_2 + T_0 / 2$ $S_2 = T_0 / 2$
6	$S_1 = T_1 + T_2 + T_0 / 2$ $S_3 = T_0 / 2$ $S_5 = T_1 + T_0 / 2$	$S_4 = T_0 / 2$ $S_6 = T_1 + T_2 + T_0 / 2$ $S_2 = T_2 + T_0 / 2$

**5. The simulation results**

A prototype of the proposed system for the simulation of MATLAB software and the software environment of the underlying collateral Simulink wire Sim power system are used to power the system. MATLAB is one of the most reliable and powerful software specialized in the analysis of electrical systems that are used in various fields and Simulink environment is a set of blocks for which the user can easily make the simulation model to analyze the circuit [15]. The first prototype simulation parameters are: Switch (IGBT), the output power at the load, 360w, Primary Voltage Module 46.5V, output voltage converter DC-DC and DC link voltage  $V_d = 400v$  base frequency ( $f_s = 60\text{HZ}$ ), carrier frequency ( $f_z = 3\text{ KHZ}$ ), modulation index ( $a=0.9$ ), and a filter to remove low frequency harmonics,  $C_f = 400\mu\text{F}$ ,  $L_f = 800\mu\text{H}$  and an inductive load resistance ( $R_{load} = 5\Omega$ ,  $L_{load} = 2\text{mH}$ ) model for the design work is done: calculate and Sections (1 to 6), calculate and determine the duration of  $T_1, T_2, T_0$ , Calculate and determine the switching time  $T_a, T_b, T_c$ , for each transistor S1-S6 the output voltages of the inverter  $V_{iab}, V_{ibc}, V_{ica}$  for the control input  $u$  send the information to the framework Space, plotted using MATLAB simulation results. First, the switching time and Table 4 and 5 ties are designed for the simulation is shown in Figure 6. Then the vector modulation control design and simulation are shown in Figure 7. Finally, an overview of the module integrated converter system is simulated as shown in Figure 8. The system operates in a continuous mode and the results are shown in Figure 9 and 10. VLs are load line voltages, IIs are output current of the inverters, and ILs is the current phase load requirements.

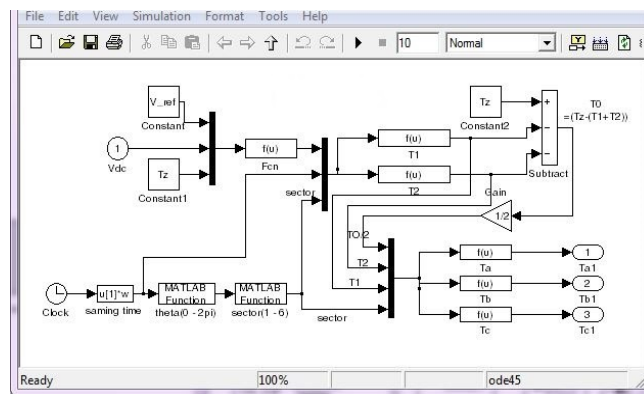

Figure 6. Simulation switching time

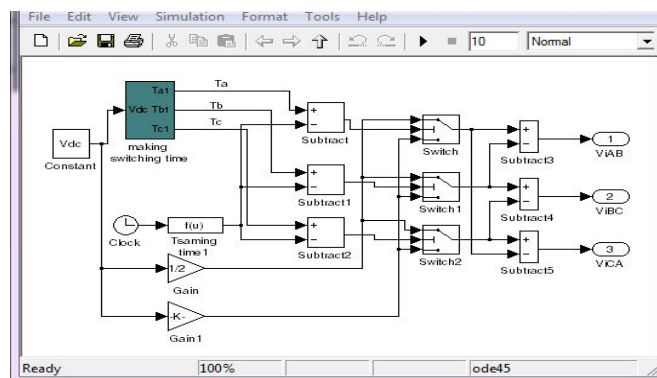

Figure . 7 . Outline vector modulation control

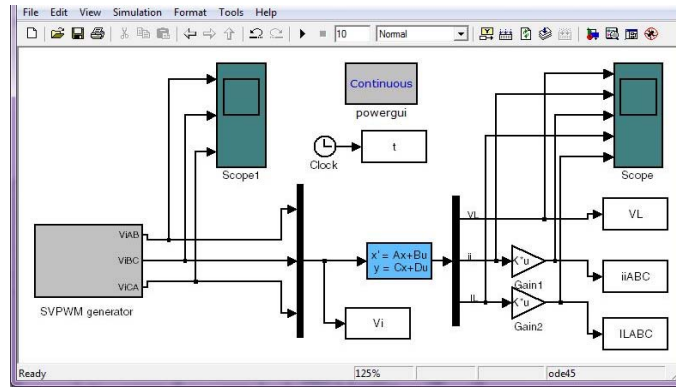

Figure 8. Overview of Photovoltaic Systems with Space Vector Modulation

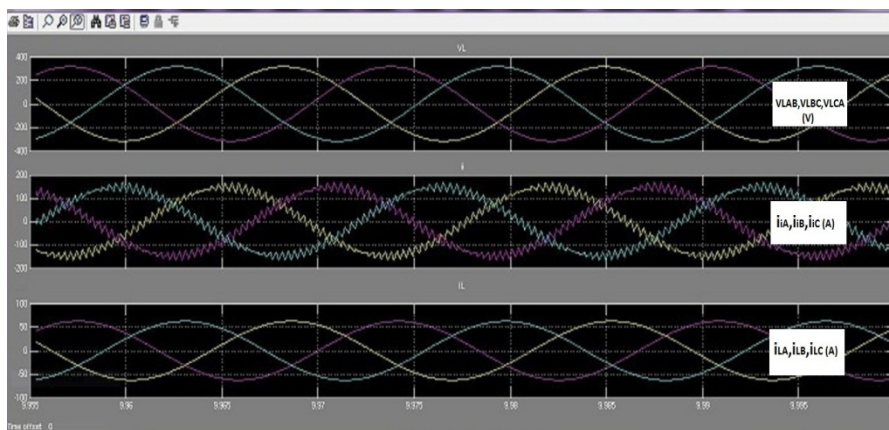

Figure 9. From top to bottom, (VLAB, VLBC, VLCA), (iia, iib, iic), (iLA, iLB, iLC)

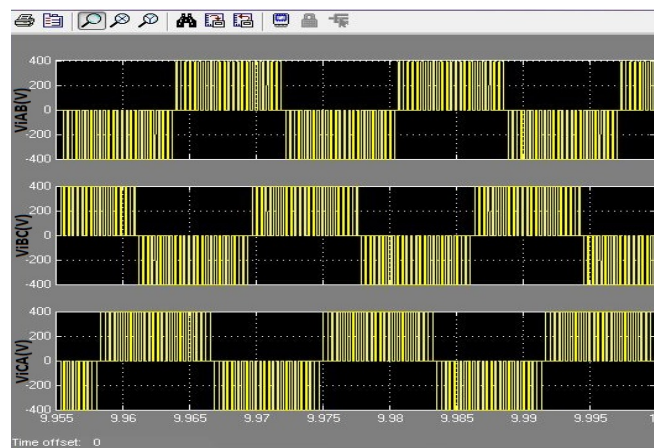

Figure 10. Output line voltage inverter

According to Figure 9 and 10 clearly seen that space vector modulation method using a two-level system, the output voltage reaches the desired sine wave approach is load well and harmonic generation is negligible.



## 6. Indexes Superior Two-level Space Vector Modulation Integrated Photovoltaic System

In a similar system with the same 3 phase marked by a constant voltage 400V modulation index  $a= 0.9$  and the same switching frequency 1KHZ, Index Total Harmonic Distortion (THD) is better than the sinusoidal pulse width modulation and pulse width modulation compared with multilevel modulation  $n \geq 3$  (N number of levels) of (THD) is higher, that in Table 4 results analysis using MATLAB and analysis (FFT) for is used for harmonic analysis is given.

Table 4. THD values for conventional modulation methods

parameters	PWM	SPWM	SVPWM 2level	SVPWM 3level	SVPWM 5level
<b>Vab</b>	%4.91	%4.8	%4.58	%3.61	%1.53
<b>Vbc</b>	%5.02	%4.92	%4.83	%3.76	%1.84
<b>Vca</b>	%5.69	%5.13	%4.96	%4.39	%1.43
<b>Ia</b>	%13.21	%12.01	%11.86	%6.89	%4.22
<b>Ib</b>	%15.07	%14.94	%13.91	%8.23	%3.26
<b>Ic</b>	%16.98	%16.87	%15.29	%7.86	%2.41

The index of THD output will be lower and lower losses can represent a modulation of the harmonics are eliminated. As a result of (THD) below, the system performance will be better and better efficiency. Inverter Output parameters are parameters in the table above. In terms of economic indicators for multilevel modulation systems for  $n \geq 3$  a photovoltaic system integrated into a single integrated photovoltaic manufacturing cost compared with two-level modulation (SVM) is more expensive and the result is not economically efficient. THD index for photovoltaic system integrated with a two-level method for use in a dwelling unit vector modulation index is acceptable and can provide good quality. The economic cost of a photovoltaic system integrated with a two-level modulation (SVM) relative to the sinusoidal pulse width modulation and pulse width modulation may be slightly higher cost, but over time, the variable costs, including annual service and consider other possible failures, this price plus the cost of minor repairs and servicing system is quite efficient, during the time the full benefit of using this type of system is finished. Systems with higher modulation  $n > 2$  per level (... , 3,4,5) that is added (by considering more complex control systems and need that extra fees are added to the cooling system) between 35% to %45 would increase. After the economic is not too difficult in terms of practical applications such as mobile control system is complex and expensive, although the characteristics of the system better than the system has a two-level modulation vector. In terms of speed, the proposed system has good speed and proportion (PWM) and (SPWM) spent less time in the output voltage reaches the desired level and this means faster performance and better quality. In terms of switching to a lower number of switching in a switching period  $T_s$  requires less stress means less current and voltage and as a result, the useful life of more switches and less heat generated, resulting in fewer casualties [6]. (Number of additional switching losses increases and reduces the useful life of systems and components and switches.) It would be much higher switching frequency standards Total Harmonic Distortion (THD) increases, but the increase in mortality switching converters leads to [11-12]. Methods (PWM) and (SPWM) and the modulation vector  $n > 3$  switching on large high-frequency harmonics produced high-pass filters that should be used to eliminate harmonics generated [3]. This means additional costs and therefore cost more. The inverter (SVPWM two-level) proposed photovoltaic system voltage deviation due to less number of switches (DC) (unbalanced load capacitance [12], that modulation with less than ,  $n > 2$  which means lower ripple and improve system efficiency. Overall efficiency of the proposed system reached 97.9% at the maximum



output power. The efficiency of the control system (SPWM) and (PWM), respectively, 96.3% and 95.2% is reached. Which is depicted in Figure 11.

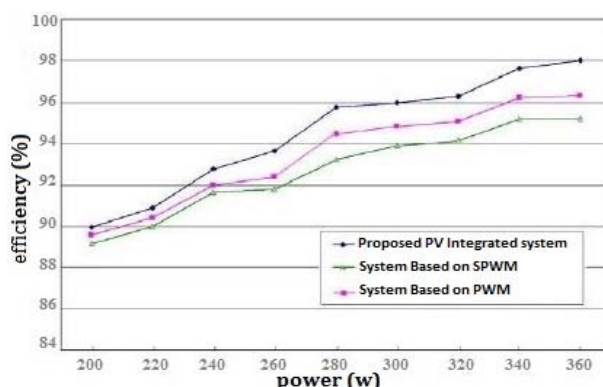

Figure 11. Outcomes measured

## 7. Conclusion

In this paper, a photovoltaic system integrated with a two-level inverter modulation space vector was provided. The structure of this system was proposed. The structure was determined from the voltage source inverter. The two-level space vector modulation control method is presented and a prototype is designed to evaluate and compare the output voltage 360w power link (DC) 400v and the output voltage of the module 46.5v to yield 97.9% has been reached, that ratio (SPW M) compared to 1.6% (PWM) 2.7% improved with MATLAB simulation software, and a few examples of pulse width modulation control systems were compared. In terms of standard low Total Harmonic Distortion Harmonic generation and economic systems studied and with respect to the parameters of a photovoltaic system is an ideal system in terms of economic efficiency and speed to achieve the desired output voltage and switching rates in a switching cycle. In general, for low and medium voltage of a photovoltaic system is a good option. It is suggested that the sample applications switches press zero current switching (called ZCS) may be used both in terms of lowering production cost and the cooling system life and reduce overshoot and flow switching and reduce noise caused by electromagnetic interference caused by and finally, raise the efficiency of photovoltaic modules in the system must be integrated close to the transducer. Expected delivery system for use in a practical system that requires low production cost and high efficiency are to be used.

## References

- [1] Haj Saghti A. Principles and application of solar energy. Tehran: University of Science and Technology; 2002.
- [2] Kazemi Kargar H, Norouzi M. Photovoltaic panels. Tehran: Arad's book. 2011.
- [3] Enrique JM, Duran E, Sidrach-de-Cardona M, Andujar JM. Theoretical assessment of the maximum power point tracking efficiency of photovoltaic facilities with different converter topologies. *Sol. Energy*. 2007; 81(1): 31-38.
- [4] Meinhardt M, O'Donnell T, Schneider H, Flannery J, Mathuna CO, Zacharias P, Krieger T. *Miniaturised low profile module integrated converter for photovoltaic applications with integrated magnetic components*. In: 14<sup>th</sup> IEEE Applied Power Electronics Conference and Exposition. 1999: 305-311.
- [5] Mohan N, Undelnd T, Robbins WP. Power Electronics: Converters, Applications and Design. Soltani J, Rastegar Fatemi MJ, Abjad NR. Tehran: Requires knowledge. 2013.
- [6] Wu B. Power Electronics: converters, high power drivers. Azizi chanad B. Nahr Danesh, Tehran: 2012.
- [7] Rashid MH. Power electronics handbook: devices, circuits and applications. Third edition. Elsevier Inc. 2011.
- [8] PC krause, O Wasynczuk, et al. Analysis of electric machinery and Drive system. 2002.

- 
- [9] Zheng Shicheng, Xia Wei, Wang Wenjuan, Ge Lusheng. *Research on PV Water Pumping System Based on SVPWM and Its TMPPT*. The Second IEEE Conference on Industrial Electronics and Application (ICIEA 2007). Harbin, China. 2007: 1384-1388.
- [10] JS Hu, KY Chen, TY Shen, CH Tang. Analytical solutions of multilevel space-vector PWM for multiphase voltage source inverters. *IEEE Trans. Power Electron.* 2011; 26(5): 1489-1502.
- [11] Shijie Yan, Qun Zhang, Heng Du. *A simplified SVPWM Control Strategy for PV Inverter*. 24<sup>th</sup> Chinese Control and Decision Conference (CCDC). 2012: 225-229.
- [12] Sutikno T, Hwa WJ, Jidin A, Idris NRN. A simple approach of space-vector pulse width modulation realization based on field programmable gate array. *Electric Power Components and Systems*. 2010; 38(14): 1546-1557.
- [13] M Zadehbagheri, R Ildarabadi, M Baghaei Nejad. Sliding mode control of a doubly - fed induction generator for wind energy conversion system. *International Journal of Scientific & Engineering Research*. 2013; 4(11) 2229-5518.
- [14] M Zadehbagheri, R Ildarabadi, M Baghaei Nejad. A Review on Speed Control Techniques of Separately Excited DC Motor. *TELKOMNIKA Indonesian Journal of Electrical Engineering*. 2015; 13(1): 106-113.
- [15] M Zadehbagheri, R Ildarabadi, M Baghaei Nejad. Review of the UPFC Different Models in Recent Years. *International Journal of Power Electronics and Drive System (IJPEDS)*. 2014; 4(3): 343-355.