

## Development of Smart Chicken Poultry Farm

Hasmah Mansor\*<sup>1</sup>, Ammar Nor Azlin<sup>2</sup>, Teddy Surya Gunawan<sup>3</sup>, Mahanijah Md Kamal<sup>4</sup>, Ahmad Zawawi Hashim<sup>5</sup>

<sup>1,2,3</sup>Department of Electrical and Computer Engineering, Kulliyah of Engineering,

<sup>4</sup>International Islamic University Malaysia · Faculty of Electrical Engineering,

<sup>5</sup>University Technology Mara, 40450 Shah Alam, Selangor, Myra Farm & Services Sdn Bhd, PT311, Mukim Sungai Gumut, 44100 Kalumpang, Tanjung Malim, Perak

---

### Article Info

#### Article history:

Received Nov 26, 2017

Revised Jan 29, 2018

Accepted Feb 21, 2018

---

#### Keywords:

Agriculture  
ATMega328  
Chicken Farm  
PID controller.  
Wireless RF

---

### ABSTRACT

In Malaysia, most agriculture industries are still using conventional method to operate. All routines in monitoring and control of chicken poultry farm, for example, utilise man power where the source and energy are very limited. However, the demand from consumers towards the agricultural output is increasing day by day and requires more advanced farming technology in order to obtain maximum efficiency. This paper is focused on the development of smart chicken poultry farm to provide monitoring and control of the farm condition. The electronics, embedded systems and wireless technology are integrated with farm monitoring. Using Master-Slave concept, sensors are used to measure the ambient temperature, ammonia and humidity of the hall of chicken poultry for each slave. The sensors' readings are then transmitted wirelessly over radio frequency by serial communication using HC-12 RF module to master for further data processing. The design process of both master and slave involved the interfacing of microprocessor, ATMEL ATMega328 with several analogue sensors, LCD, buzzer, relay output, monetary push button and light indicator. Based on the readings from the sensors, the microcontroller produced the output which is connected to the fan for better air ventilation in the chicken poultry farm. Furthermore, PID controller has been integrated to optimize the output control method, hence optimizing hall condition which results to better output for the farm. The system has been successfully implemented and tested at Myra Farm & Services, located at Kalumpang, Tanjung Malim, Perak, Malaysia.

*Copyright © 2018 Institute of Advanced Engineering and Science.  
All rights reserved.*

---

### Corresponding Author:

Hasmah Mansor  
Department of Electrical and Computer Engineering, Kulliyah of Engineering,  
International Islamic University Malaysia (IIUM),  
Jalan Gombak, 53100 Kuala Lumpur, (+603) 6196 4525  
E-mail: hasmahm@iium.edu.my

---

### 1. INTRODUCTION

There is a need to improvise the monitoring system in farming, especially in poultries. There are some variables that can be controlled and manipulated to produce a proper caging condition in which the slightest difference will affect the output of the farm, hence the importance of having the system. Designing process involves many aspects and theories to be put into consideration. One of the main concern in animal farming is to increase the production with minimum negative impact to the environment. Therefore, combination of crops and livestock was suggested by the Ministry of Food Agriculture and Livestock of Turkey to reduce environmental fluxes while maintaining a better regulation of stocks [1]. The general idea was to propose a set of algorithms to control and manipulate environmental variables like liquid level, temperature and humidity by fuzzification, defuzzification and PID controller [2].

It is very essential if a sensing system can be developed to detect ammonia at ppm levels with minimum cost of production [3] since the risk of hazard is the same for both human beings and farm animal. Furthermore, temperature sensors for farms are purposely being located in the middle in the air to obtain the surrounding temperature of the hall. Another key element of farm monitoring is the humidity sensing system. Humidity control and measurement are common in agricultural production, medicine processing, and textile industries and meteorological services by means of optical fiber. They also discovered that RH possesses a low temperature cross-sensitivity, based on studies [4].

Controllers are the core of almost all hardware and software systems in the world. Over the past decades, industrial makers have moved towards a simpler controller, mostly by implementing programmable logic controller (PLC). While PLCs are a very good solution, Rida (2014) suggested to develop a mini PLC based on the implementation of ATMEL ATmega256 [5]. The usage of microcontrollers in real life applications have been the trend of electronic enthusiast that might consist of flow and control, readings, calibrations and even controlling system. Hence, it is concluded that this project will be implementing a microcontroller-based system with the ability to communicate wirelessly with the selected arrays of sensors available in the current market. The design and specifications of the project is based on the user requirements given by Myra Farm & Services where the main industry is chicken poultry farm. The main requirement is to obtain optimal temperature, humidity, concentration of ammonia, and air flow of the chicken cage for the maximum throughput of the chicken farm.

**2. MASTER-SLAVE MODULE DESIGN OF CHICKEN POULTRY FARM**

This section describes the methodology used in the proposed smart chicken farm. The details of Master-Slave module configuration has been presented in [6]. The prototype has been installed and tested in the Myra Farm & Services, located at Kalumpang, Tanjung Malim, Perak, Malaysia.

**2.1. Master Module Design**

The overall layout of the system that had been fabricated can be divided into four main parts; power supply, input components, output components and communication modules for both master and slave modules, as shown in Figure. 1 and Figure. 2.

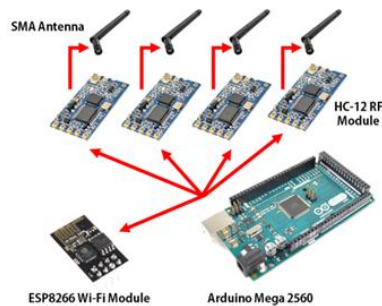

Figure 1. Power Supply Layout for Master

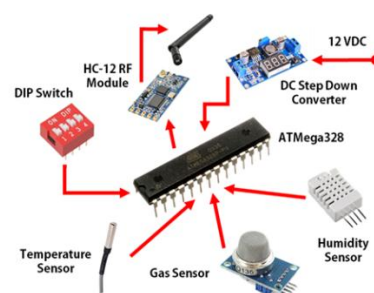

Figure 2. Communication Modules for Master

**2.2 Slave Module Design**

For each slave modules, 12 VDC were supplied to the DC step down converter to step down the voltage to 5 VDC, since that is the supply limit and the operating voltage of ATmega328 microcontroller. Each module is connected with HC-12 RF module, DIP switch, sensors and several other electronic components such as crystal oscillator, switches and LEDs. Each slave module is connected to 2 temperature sensor probes, a DHT22 humidity sensor and MQ-135 gas sensor to detect ammonia levels. These are the three input parameters considered in this project. The detail operation of ammonia detection, wireless temperature sensor and humidity sensor can be found on [7-11]. The RF module for each slave modules are set into different channel relative to its pair in the master module, to avoid data clashing, as shown in Figure. 3.

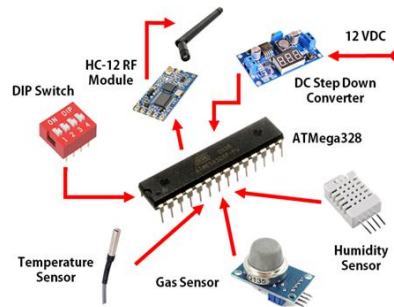

Figure 3. Components Layout for Slave

### 2.3 Data Conversion and Calibration

The purpose of conversion is to convert analogue values ranging from 0 to 1023 into the actual temperature, humidity and ammonia values.

$$Y = \frac{1023}{\text{Analogue Vaues}} \times \text{Temperature} \quad (1)$$

where  $Y$  is the calibration value. From (1), it can be concluded that the value of  $Y$  will be adjusted to produce the desired output. To reduce tolerance values, all readings were taken 5 times and the average is calculated. The flow of all sensor tests can be represented in Figure. 4.

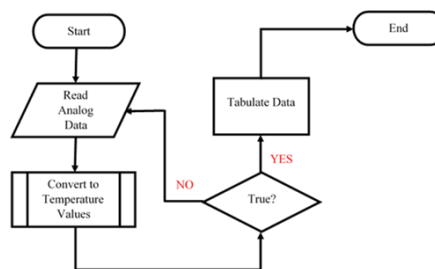

Figure 4. Flowchart of Sensor Test

## 3. RESULTS AND ANALYSIS

This section presents the results and analysis of the smart chicken poultry farm. The test was started with calibration of the sensors.

### 3.1. Calibration Values

To do calibration, the reference point must be considered. First, actual temperature of the poultry farm was taken and the value was 27.5 °C. From the reading, the analogue value showed 115. From Eq. (1), the calibration value for temperature,  $Y_T$  is 224.63. Second, the actual humidity of the poultry farm was taken and the value was 55%. From the reading, the analogue value showed 435. Again, from Eq. (1), the calibration value for humidity,  $Y_H$  is 129.34. For ammonia, it was measured the actual reading at the poultry farm was 10 PPM and the analogue reading showed 193. From Eq. (1), the calibration value for ammonia,  $Y_A$  is 53.01. The calibration was successfully performed, however the effect of disturbances such as change in environmental conditions are not considered in the test.

### 3.2 Testing of Sensors

Table 1 and Table 2 shows reading tests for temperature and humidity sensors that were used in this project. Tests were conducted at the indoor and outdoor campus environment, before it was applied at the actual chicken farm. The tests were conducted at laboratory, mosque and compounds at IIUM. The tests for both temperature and humidity sensors were conducted simultaneously under the same environment. For the

purpose of comparisons, three readings were taken by using different temperature measurement sensors i.e. LM35, probe and AccuWeather. DHT11 and DHT12 were used to measure humidity.

Table 1. Tabulated Results of Temperature Sensor Test

Environment	Sensor / Reference	Analog Reading	Temperature Value After Conversion
Robot Design Lab (Indoor)	LM35	119	28.46
	Probe	119	28.46
I-Brown, KICT (Indoor)	LM35	115	27.50
	Probe	115	27.51
E2 – 1 Square (Outdoor)	LM35	135	32.28
	Probe	136	32.52
	AccuWeather	-	32.00
KICT Roundabout (Outdoor)	LM35	140	33.48
	Probe	142	33.96
	AccuWeather	-	34.00
SHAS Mosque Compound (Outdoor)	LM35	131	31.33
	Probe	131	31.34
	AccuWeather	-	31.00

Table 2. Tabulated Results of Humidity Sensor Test

Environment	Sensor / Reference	Analog Reading	Humidity Value After Conversion
Robot Design Lab (Indoor)	DHT11	393	49.59
	DHT22	393	49.63
I-Brown, KICT (Indoor)	DHT11	406	51.30
	DHT22	406	51.23
E2 – 1 Square (Outdoor)	DHT11	436	55.03
	DHT22	436	55.13
KICT Roundabout (Outdoor)	DHT11	435	55.00
	DHT22	435	55.00
SHAS Mosque Compound (Outdoor)	DHT11	443	55.93
	DHT22	443	55.97

Results in Table 1 and 2 showed that there are consistencies in the measurement reading of temperature and humidity, at the indoor and outdoor measurements. Temperature and humidity for indoor environments are lower than outdoor environments. Gas sensor was tested at IIUM compound and also at the actual farm. The gas sensor detects the presence of ammonia in the air. Figure. 5 shows the readings of the gas sensor over time (in minutes). The measurement was made in 15 minutes. Since there were no ammonia presence in IIUM, the reading is consistent (at 200) compared to the measurement made at the actual farm. At actual farm, there was drastic increase in readings since the ammonia gas at that time was at the peak. Readings taken were just after harvesting period, where traces of ammonia produced by the live stocks were still present.

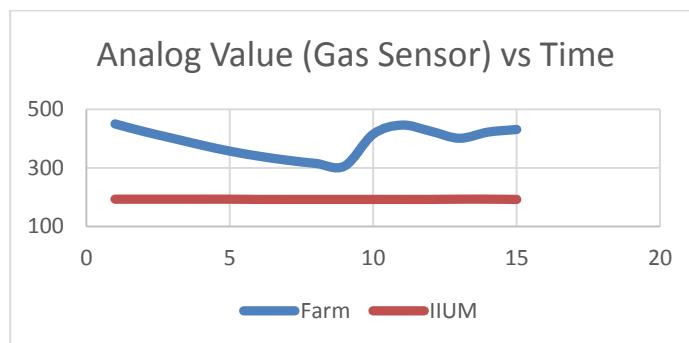

Figure 5. Graph of Analogue Value versus Time for Gas Sensor

**3.3. Output Parameter**

All inputs from sensors were processed to define the conditions for output mechanisms. For this project, the master module outputs pulse width modulation (PWM) signals to control a few series of fan speed. The system needs to consider the readings from all 4 slave modules to produce an output. From Figure. 6, the readings from slave 1 (S1) will be different from other slave modules due to their location in relative to the fan zone. The ammonia level on S1 zone will be lower if compared to S4 zone since S1 zone is much closer to the fan, however, the temperature at S1 zone will be higher due to heat emitted from the fan itself. However, this project will be considering the average reading for all slave modules since this approach is straight forward, and at the same time this project is assumed to be in ideal condition without disturbances. There is a total of 14 fans arranged for each hall, and there are 7 phases of triggering the fans depending on the age of the chickens. For example, phase one shall only be triggered when the chickens are at 6 days and less. The function of the fan is to pull out ammonia gasses from inside the hall while producing a wind flow that will decrease the temperature of the hall. The higher the speed of the fan, the lesser time it took to cool down the hall. Therefore, the input response can be considered as ramp input as in Figure. 7. Where the speed of the motor is directly proportional to the sensor values.

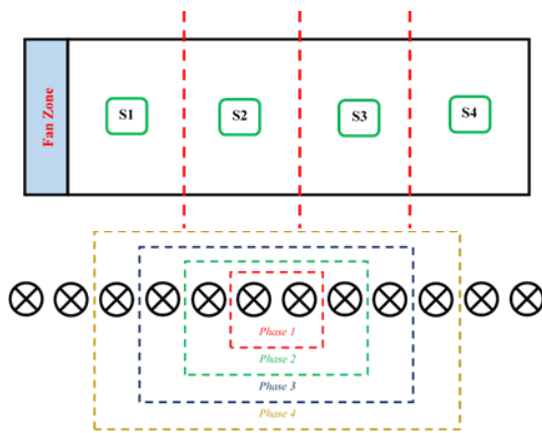

Figure 6. Fan Layout of the Hall

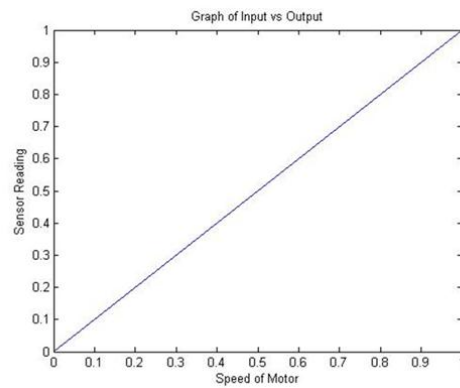

Figure 7. Graph of Sensor Value (Input) vs Speed of Motor (Output)

In real life situation, direct mapping of input to the output does not produce the best output, because there will have tendencies for fault readings on certain zones, most of which there are leftovers of ammonia gasses. Therefore, the output can be optimized by using a control method, known as proportional, integral and derivative (PID). Considering a ramp input, the transfer function of the of the negative feedback system with PID controller is;

$$T(s) = \frac{k_d s^2 + k_p s + k_i}{(1 + k_d) s^2 + k_p s + k_i} \tag{2}$$

From Eq. (2), the values for  $k_p = 10$ ,  $k_i = 3$  and  $k_d = 3$ , the transfer function would be

$$T(s) = \frac{3s^2 + 10s + 3}{4s^2 + 10s + 3}$$

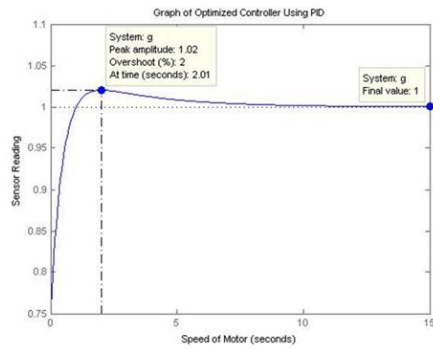

Figure 8. Step Response of the Transfer Function

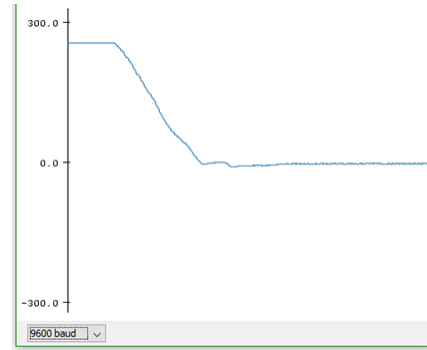

Figure 9. Output Speed from Microcontroller

Figure. 9 represents the PWM output of DC motor from the microcontroller, which ranges from 0 (minimum) to 255 (maximum). The speed reduces as the reading of the sensors decreases, which eventually stays at rest then the system achieves its set point. The peak amplitude of the system in Figure. 8 is at 1.02, the rise time is 0.684 seconds, settling time is 6.51 seconds and the final value is 1. From the graph, the percentage overshoot is 2%.

**3.4 Radio Frequency Module**

This project had tested the critical parameter of the case, which is the distance and baud-rate of the modules. The result of the test is as follows;

Table 3. Tabulated Results of Module Test

Distance (Meters)	Baud-Rate	Partitioned	Open Air
2	9600	√	√
	115200	√	√
10	9600	√	√
	115200	X	√
30	9600	√	√
	115200	X	√
100	9600	X	√
	115200	X	√
200	9600	X	√
	115200	X	√

Table 3 shows the tabulated results of RF module test that was done on both partitioned and open air environment. The baud rate for microcontroller, transmitter and receiver was set to be at 9600 and 115200. Few series if ping was done to see if the attempt is successful (√), which can be known when master module successfully grabbed the data and displayed it on serial monitor. Otherwise, it was considered error (X). This can be concluded that the baud rate does have an impact on the transmission for partitioned walls, mostly because the speed is too fast for the microcontroller to display in serial monitor. On the other hand, open air tests show fully successful results since there are no disturbances for the radio frequency waves.

**3.5 Power Consumption**

One of the main concerns of this system is the power consumption. Therefore, components were selected based on its supply power and operating power so that it can remain as low as possible. Theoretically, the power consumption was measured by assuming the operating power of the whole system will not exceed the power that is supplied.

$$P_T = I_S V_S \tag{3}$$

$I_S = 1$  A and  $V_S = 12$  VDC. Therefore, from (3),  $P_T = 12$  Watts.

The current of the working system was measured at the output of the voltage regulator, and using power Eq. (3), the result obtained is as follows;

Measured current,  $I_E = 0.0578$  A and  $V_E = 12$  VDC. Therefore,  $P_E = 6.936$  Watts.

The efficiency from theoretical power,  $P_T$  in relative to experimental power,  $P_E$  is calculated as follows:

$$\text{Efficiency} = \frac{12 - 6.936}{12} \times 100 = 42.20\%$$

Therefore, it can be concluded that the operating power of the system is lesser than the supplied power, hence making it 42.20 % efficient. To put it in a perspective, if a battery that has the capacity of 12 Watt-Hour can be able to power up a system of 12 Watts for an hour, then the same battery could be able to power up this system for  $\pm 1.5$  hours, hence the system can be considered as efficient. However, since this project is using a constant power supply from DC adapter, then the operating power can be said to be at constant 12 Watts, which is relatively small for an everyday life instruments.

#### 4. FIELD TESTING ARRANGEMENT

The field testing of the actual poultry farm is located approximately 100 KM north of Kuala Lumpur to the district of Kalumpang, Tanjung Malim. The chickens were 32 days old, 2 days prior to harvesting by the time the calibration process was done, which is the time when the chickens produced the highest amount of ammonia. The pictures of the farm are shown in Figure. 10-13.



Figure. 10 The Poultry Chicken Farm at Kalumpang



Figure. 11 Workspace Set-Up During Field Test



Figure. 12 CCTV Feeds for 4 Halls of the Farm



Figure. 13 Hall 1, the Test hall for Sensor Readings

#### 5. CONCLUSION

The objective of this project, to develop smart chicken poultry farm has been achieved. The smart chicken poultry farm has been installed and tested at Myra Farm & Services in Kalumpang, Tanjung Malim, Selangor. The system was tested in the university area before fully installed and implemented at the actual farm. The system provides monitoring and control of the farm condition in modular form. From the sensors readings, the output parameters (series of fan speed) have been successfully optimized using PID controller. The sensors (slave) installed at the farm are connected wirelessly to the master and at the same time very easy to install with minimal cost. The production cost to develop smart chicken poultry farm is below RM 1,200, as well as keeping the operating power at 6.936 Watts. With the success of the development of smart

chicken poultry farm at Myra Farm & Services, it is expected that the farm could produce more healthy chicken, reduce the number mortality and in consequence, could fulfil the demand of from the consumers.

#### ACKNOWLEDGEMENT

This research is funded by International Islamic University Malaysia (IIUM) and Ministry of Higher Education Malaysia under the research grant RIGS16-066-0230. Special thanks to Myra Farm & Services Sdn. Bhd. for the collaboration of work.

#### REFERENCES

- [1] Hakan ERDEN, "Livestock Monitoring System," in *Ministry of Food and Livestock*, Ankara, Turkey, pp. 1–4, 2014.
- [2] Zohaib Mushtaq, Akbare Yaqub, Muhammad Jabbar, Adnan Khalid, Saania Iqbal, Kamran Zeb and Abid A.Naqvi, "Environment Control System for Livestock Sheds Using Fuzzy Logic Technique," in 2016 3rd International Conference on Information Science and Control Engineering, pp. 1-2, 2016.
- [3] G. Scandurra, A. Arena, C. Ciofi and G. Saitta, "Detection of Ammonia at PPM Levels Using Titanium Dioxide/Polyaniline Films Deposited on Plastic Sheets," Proceedings of IEEE International Instrumentation and Measurement Technology Conference, pp. 1-2, 2012.
- [4] Haiwei Fu, Youhua Jiang, Jijun Ding, Jingle Zhang, "Low Temperature Cross-Sensitivity Humidity Sensor Based on a U-Shaped Microfiber Interferometer," IEEE Sensors Journal, Vol. 17(3), pp. 644-649, 2016.
- [5] Mohamed Er Rida, Fuqiang Liu, Yassine Jadi, "Design Mini-PLC based on ATxmega256A3U-AU Microcontroller," *Proceedings of International Conference on Information Science, Electronics and Electrical Engineering*, pp. 1034-1037, 2014.
- [6] A. A Nor Azlin, H. Mansor, A. Z. Hashim and T.S. Gunawan, "Development of Modular Smart Farm System," in Proc. of the 4th IEEE International Conference on Smart Instrumentation, Measurement and Applications (ICSIMA) 2017, Putrajaya, pp. 1-6, 2017.
- [7] G. Scandurra, A. Arena, C. Ciofi and G. Saitta, "Detection of Ammonia at PPM Levels Using Titanium Dioxide/Polyaniline Films Deposited on Plastic Sheets," Proceedings of IEEE International Instrumentation and Measurement Technology Conference, pp. 1210-1212, 2012.
- [8] Pyoungwon Park and K.A.A.Makinwa, "A Resistor-Based Temperature Sensor for a Real Time Clock with 2ppm Frequency Stability," Proceedings of the 40th European Solid State Circuits Conference (ESSCIRC), pp. 391-394, 2014
- [9] Stephan Wildermuth, Andreas Decker, Jörg Gebhardt and Paul Szasz, "Non-Invasive, Energy-Autonomous and Wireless Temperature Sensor for The Process Industry," Proceedings of 21st International Conference on Emerging Technologies and Factory Automation (ETFA), 1-4, 2016.
- [10] Xinpeng Chen, Xiangdong Chen, Ning Li, Xing Ding, Xuan Zhao, "A QCM Humidity Sensors Based On GO/Nafton Composite Films With Enhanced Sensitivity," 2016 IEEE Sensor Journal, Vol. 16(24), pp. 8873-8883, 2016.
- [11] T.S. Gunawan, I.R.H. Yaldi, M. Kartiwi, and H. Mansor. Performance Evaluation of Smart Home System using Internet of Things. *International Journal of Electrical and Computer Engineering (IJECE)*, 8(1), pp. 400-411, 2018.