

An Analysis of a Flexible Dry Surface Electrodes

Amelia Wong Azman¹, Muhammad Farhan Azman², Siti Mohd Ariff³, Yasir Mohd Mustafah⁴,
Huda Adibah Mohd Ramli⁵, AHM Zahirul Alam⁶, Mohamed Hadi Habaebi⁷

^{1,2,3,5,6,7} Electrical and Computer Engineering Department, Kulliyah of Engineering,

⁴ Mechatronic Engineering Department, Kulliyah of Engineering,
International Islamic University Malaysia, Kuala Lumpur, Malaysia

Article Info

Article history:

Received Jan 5, 2018

Revised Mar 5, 2018

Accepted Mar 20, 2018

Keywords:

PEDOT:PSS

Silver Nanoparticles

Electrical Stimulation

Fabric

ABSTRACT

In the medical field, electrodes are commonly used either to retrieve signals or to conduct current. Most of the off-the-shelf surface electrodes are made from metal or rigid substrates. This paper presents a work on designing a new flexible dry electrodes using poly (3,4-ethylenedioxythiophene) polystyrene sulfonate and silver by means of dispenser printing technology. The polyester cotton fabric was selected as the substrate in this electrode designed. To analyse the new proposed composites of poly(3,4-ethylenedioxythiophene) polystyrene sulfonate and silver, different mixtures have been applied. Results from the experiment show that the conductivity of the proposed flexible electrode is comparable with the commercialized pre-gelled electrode when applied to an electrical stimulator device. Eight out of ten subjects under test described no difference in comfort between the proposed electrodes and pre-gelled electrodes.

Copyright © 2018 Institute of Advanced Engineering and Science.
All rights reserved.

Corresponding Author:

Amelia Wong Azman,

Electrical and Computer Engineering Department, Kulliyah of Engineering,

International Islamic University Malaysia,

Kuala Lumpur, Malaysia.

Email: amy@iiu.edu.my

1. INTRODUCTION

The revolution of the design in the medical electrode has been started over past 19th century. Multiple researches and papers have been done to improve the quality and the performance of the medical electrodes. Medical electrodes have been widely used in the hospitals and other medical institution for variance applications. These applications include recording, monitoring as well as stimulation purposes. In many cases, the design of medical electrodes need to be optimized and performed at the highest level in order to capture clear signal from the body as well as to stimulate muscles during rehabilitation process. Latest advancement of electrical stimulation in rehabilitation process includes improving muscle tone as well as preventing muscle atrophy from occurring especially due to sport's related injuries [1]. Artifacts produced during the monitoring and the stimulation process will degrade the signals and consequently affect the quality of the medical procedure.

The electrodes can be generally divided into two classes which are the invasive and non-invasive or the surface electrodes. The use of invasive electrode involve the action of piercing the electrodes underneath the skin surface whereas the non-invasive electrode is applied onto the skin surface which make the invasive electrode inconvenience to be used without experts and clinical intervention. In the case of electrical stimulation, there are cases where patients inevitably require invasive electrode. However, development in non-invasive electrode has shown significant improvement in the outcome of the non-invasive electrode pushing its way forward in this industry. Another significant advantage of the surface electrode is that it is convenient to be used outside of the clinical settings i.e. does not require experts' supervision making it

easily accessible at the hospitals, pharmacy and health care premises. The surface electrodes are widely used along with the stimulation devices.

The non-invasive electrode can be divided into wet and dry electrodes. The wet electrode requires electrolytic coupling fluid, usually in the form of gel or paste as an interface between the electrode and the skin. This gel or paste lowers the skin-electrode interface impedance by creating an ionic path [2]. However, it has been reported in some cases that the gel or paste may increase the risks of skin irritation during treatment. Furthermore, the gel or paste once evaporated or dried may result in increase of artifacts [3]. Sweats due to perspiration process can also make the gel lose its contact with the skin.

The dry electrode on the other hand, makes use of the sweats to complement the responsibility of the gel or paste of the wet electrode [4]. The perspiration which mainly excretes sodium chloride acts as electrolyte that enters the pore and increases conductivity. Moreover, the product of the perspiration process moisturizes the electrodes and makes the electrode surface area becomes more effective. Dry electrodes are normally made from metal such as silver or copper. A disadvantage of metal-based dry electrode is normally rigid that increase motion artifact during treatment. This metal-based electrode is normally applied to the skin with some pressure which can cause inconvenience to users. To overcome these limitations, flexible electrode has been introduced in the market. The new electrode design is aimed to have the ability of a commercialized off-the shelves electrode and at the same time enhances the stimulation experience among the users [5].

On the other side of the research spectrum, printable circuit technology for designing new prototype has been widely investigated. Printable circuit technology open new door in the development of manufacturing processes for various products. This technology offers great plus point as a new method in designing new electrodes. Therefore, this work presents a design and development of dry flexible non-invasive electrode incorporating the printing technology. The new electrode design is aimed to have the ability of a conventional off-the shelves electrode and at the same time enhances the stimulation experience among the users. The surface electrode is designed such that it can be easily used with any stimulation devices. The target application of the electrodes is for medical and health care field.

The rest of the paper is organized as follows: Section 2 describes the available substrates to make an effective flexible electrodes as well as summarizing different printing circuit technology. The description on the design and methodology is explained in Section 3. Section 4 provides the testing results, analysis and discussion of this work followed by a conclusion and recommendations in Section 5.

2. BACKGROUND

2.1. Flexible Electrodes

In this work, we have focused on utilizing flexible substrate as a way to produce flexible electrode. Our background search has been focused on polyimide, polydimethylsiloxane (PDMS) substrates and the textile substrates as the best candidates to produce flexible electrode.

The polyimide substrate (PI) is a conductive material where it often used to form cabide film. Thus, polyimide is often used to make invasive electrodes. The process to produce polyimide substrate involves a single material which reduces the requirements of other materials, hence, lowering production cost [6]. Unfortunately, polyimide is not stiff enough and lack the rigidity factor to penetrate tissue making it unsuitable as invasive electrode. The long and lengthy polyimide probes also will affect the accuracy in targeting a selected region during penetration process, as example in the sensitive part of the brain region. Thus making it a not preferable materials to use for the invasive electrodes. Moreover, polyimide substrate have the characteristic to absorb moisture, but this characteristic is not suitable for invasive electrode as it prone to cause failure in a rehabilitation process [7],[8]. This limitation however, might be useful in designing a non-invasive electrode design.

PDMS on the other hand has a high biocompatibility, structural stability, plasticity and softness feature. This increase the degree of flexibility and allowing it to bend. Thus, making it resistant to cracking when used. The production of electrodes based on PDMS is relatively simple and quick. However, the preparation of making PDMS requires care since different ratio of mixtures will make the PDMS become rigid and reduce the compressibility making it loses its capability to become a flexible electrode [9].

Just recently, textile based-electrode began to emerge. The term e-textile which is electronic textile is often used interchangeably with smart fabrics, functional apparel and even wearable technology, brings forward the idea of flexible electrodes in the health care fields. Soft electrode surfaces form the fabrics bonded well with the skin surface of a body, hence, reduces the artifact and noise generated by the motion between the electrode and the skin while inherits the advantages of the surface electrode. However, fabric on its own is usually insulators toward the electric current. Hence, the presence of the gel or paste as interface between the skin and the electrodes are required. Therefore, this work presents the design and development

of textile-based electrode, enhancing the capability of the flexible non-invasive electrodes design by means of printable circuit technology.

2.2. Printable Circuit Technology

The two most common printable circuit technologies are the two-dimensional (2D) and three-dimensional (3D) printing technology. In 2D circuit printing technology, most of the processes are operating on the flat surfaces rather than on the contours or multi-axis dimensions. Since this work involves 3D object and utilises flexible substrate, the 3D printing method is more suitable to reach the objective of this work. There are three most common printing techniques in depositing conductive material onto flexible substrates. They are the inkjet printing, screen printing as well as dispenser printing.

The inkjet printing is a simple production process which the printing process can be done by using a normal electronic inkjet printer. Inkjet printing takes the digital data from the computer and prints the data by depositing ink drops on the substrates. In the case of electrode design, the ink is conductive material which can be metal nanoparticles, liquid metal, carbon nanomaterial, and conductive polymer. However, the inkjet printing technique is not suitable for mass production due to clogging of the printing nozzle which usually can lead to higher production time and cost [5].

In screen printing technology, the ink is deposited through porous printing plate affixed to a rigid frame [10]-[11]. The circuit design or the image used in the printing is often called the mask or the stencil. As compared to the inkjet printing, thick wet layers of ink is possible to be deposited by using this technique without having to worry about clogging of the ink. The screen printing technique offers an opportunity for mass production because single frame may consist of multiple masks. Unfortunately, screen printing technique requires the ink to be at a higher level of viscosity for better resolution of the ink deposited. Besides that, dried ink left on the mask can deteriorate the resolution of the mask and affect the quality of the printed pattern.

Dispenser printing is one of a direct write printing techniques. Structures or design to be built can be directly printed directly from the computer and does not require the usage of the mask which allowed for rapid prototyping. The ink is deposited onto the substrates by using syringe according to the desired printed pattern. As compared to the inkjet printing, the dispenser printing technique suitable for mass manufacturing by using multiple syringe in an assembly line [9]. Inks in the form of suspensions and slurries or even solution is possible to be used by using dispersion printing as compared to the screen printing which require high viscosity inks. However, similar to the inkjet printing technology, the dispersion printing may suffer from clogging of the syringe due to the sensitivity of the ink behavior towards the particle size, shape, concentration and stability against aggregation due to interparticles attractive forces.

Table 1 shows the comparison between these three printing technology. Based on the summary, this work has decided to advance with the dispersion printing style due to its low implementation cost, faster turnaround time for prototyping as well as due to our selection of the conductive material for our flexible dry electrode which is in the form of solution.

Table 1. Comparison between Three 3D Printing Techniques

Method	Advantage	Disadvantage
Inkjet Printing	<ul style="list-style-type: none"> • Simple production process. • Printing process can be done by common printer in daily usage. 	<ul style="list-style-type: none"> • Not suitable for the mass production. • Clogging of the nozzle by the ink.
Screen Printing	<ul style="list-style-type: none"> • Clogging is not possible. • Mass production for single design. 	<ul style="list-style-type: none"> • Need inks with high viscosity for better resolution. • Not suitable for multiple design product.
Dispersion Printing	<ul style="list-style-type: none"> • Direct printing for rapid prototyping. • Suitable for mass manufacturing due to multiple syringes in an assembly line. 	<ul style="list-style-type: none"> • Clogging is possible due to sensitivity of the ink concentration.

3. RESEARCH METHOD

Based on the previous discussions, it has been established that the recent advancement of the printing technology allows us to print the conductive part of the electrodes. The printing process will utilise conductive ink to be printed onto flexible substrates. To achieve a flexible dry electrode, the fabric or the textile has been selected as the main substrate for the electrode as elaborated in Section 2. This section explains the material and methodology that were used to design and implement a high conductivity and low resistivity flexible electrode for non-invasive stimulation procedure. The objective is to design a nonmetal-based dry electrode without the requirement of the electrolytic gel or paste.

3.1. Material Preparations for Flexible Electrode Design

The Poly(3,4-ethylenedioxythiophene) polystyrene sulfonate or known as PEDOT:PSS which comes in the form of solution is a conductive polymer. PEDOT:PSS is conventionally use in various optoelectronics devices due to its good oxidation resistance as well as high electrical conductivity. Besides producing smooth conductive layer on deposited area, the PEDOT:PSS was selected as the main coating in this proposed electrode due to its hydrophilic characteristic [update semula]. Hydrophilic characteristic is beneficial as the electrode needs to be able to absorb sweat from perspiration process. This will take the roll of electrolytic gel or paste commonly used in commercialized wet electrode to overcome the skin impedance. Another advantage of PEDOT:PSS, it can undergo various printing techniques such as drop coating, spray coating, spin coating or various printing techniques [10]. The PEDOT: PSS 1.3 wt% in H₂O from Sigma Aldrich has been used in this work. 1.3 wt% dispersion in H₂O means the concentration of 1.3g of PEDOT: PSS in 100g of water. The conductivity of this PEDOT:PSS solution is at 1 S/cm.

Besides PEDOT:PSS, silver nanoparticles solution, SilverSol™, with two different concentrations; 2000 ppm and 5000 ppm, were used in this work. 1 ppm or part per million of colloidal silver means one milligram of silver being deposited into 1000 ml of water. In other words, 1 ppm equals to 1 milligram of silver colloidal per liter of water (1 mg/L). Silver nanoparticles is referring to the metallic silver have the size range of 1 to 100 nano meter (nm). SilverSol™ is chosen as the supplier brand because it is made of 99.99% pure noble silver with the particle size ranging from 3 to 5 nm. Silver was chosen to be used in designing our proposed electrode due to its high electrical conductivity capability. Moreover, it exhibits antibacterial, anti-fungus and antiviral properties, thus it is harmless to human body which can be useful in medical settings [11]. The antimicrobial agents characteristic of the SilverSol™ have been proven by number of tests which results in decreasing number of bacteria up to 100% [12].

Both PEDOT:PSS and silver solution as shown in Figure 1 were mix to become the conductive ink to be printed on the 65/35 polyester cotton fabrics substrates by using the dispenser printing method. By combining the silver with PEDOT:PSS, this ensure continuous conductivity of the electrode during the stimulation eliminating the conductivity problem that could occur when silver acting independently [13]. Prior to mixing the silver nanoparticles solution, 60 ml of silver solution was set to be evaporated at 100 °C until it saturates to 20 ml, reducing the liquidity state of the silver solution.

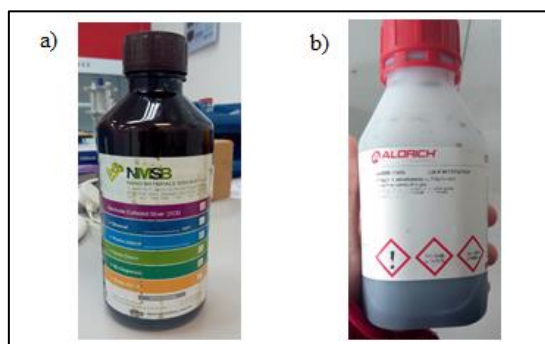

Figure 1. a) SilverSol from NMSB, b) PEDOT: PSS from Sigma Aldrich

For the conductivity and flexibility test, 3 ml of PEDOT:PSS was mixed with five different volumes of silver solution; 1 ml, 2 ml, 3 ml, 4 ml, and 5 ml. Each of the aqueous solution was stirred magnetically at room temperature for 3 hours before being loaded into the syringe to be deposited onto the substrates. The ink was printed on 1 cm² of the polyester cotton fabrics with each layer of ink deposited was set at a volume of 1 ml. The ink was printed with different number of layers for each PEDOT: PSS and silver mixture with each layer having two samples; one for post-treatment process and the other with no post-treatment process. For the electrodes with the post-treatment, the fabrics with the deposited ink are annealed on the hot plate at 100°C for 3 minutes (the estimated time for water to be evaporated). Meanwhile, for the electrodes with no post-treatment, the electrode samples were dry at the room temperature. The conductivity for each sample was examined.

For prototyping of the electrode design, 5 ml of the PEDOT: PSS was mixed with the 5 ml of the evaporated silver for both silver concentrations. The aqueous solution was put on the magnetically stirrer for 3 hours before being loaded into the syringe for printing process. The ink solution with both silver with 2000 ppm and 5000 ppm were each printed onto a 5 cm x 5 cm polyester cotton fabric. Since the electrode

prototype design was only consisted of simple geometry, the dispenser printing process was done manually by direct writing using syringe. Finally, the dried electrodes were sewed to have a 4 cm x 4 cm dimension for proper comparison with the commercialized pre-gelled electrodes as shown in Figure 2. Next, the electrodes are implemented with the stimulation devices for the verification test.

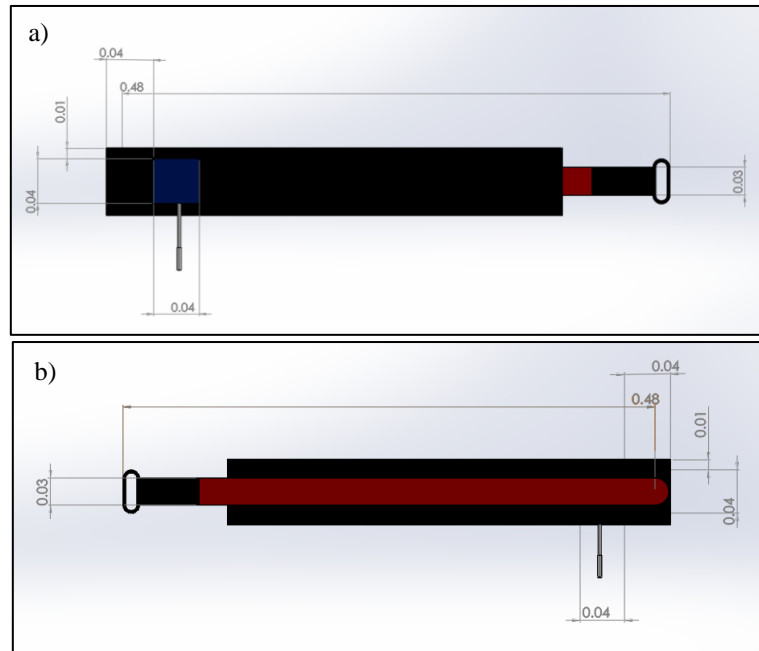

Figure 2. Electrode design scaled in meter: (a) Front view of the design. (b) Back view of the design

3.2. Conductivity and Verification Test

The performance of the electrode was evaluated in terms of the conductance of the electrode. By measuring the electric current passing through the electrodes when DC voltage is applied as illustrated in Figure 3, the conductance of the electrode, which is the reciprocal of the resistance, can be calculated by using the Ohm's Law equation. The resistor, R , is a fix value. The electrode with the lowest resistance i.e. highest conductivity will be chosen as the design for the flexible dry electrodes. Since the conductivity of the electrode can be defined as the ability of the electrode to allow the electric charges to pass through it, the sample with the higher conductivity will determine the volume of the silver to be added to the PEDOT: PSS.

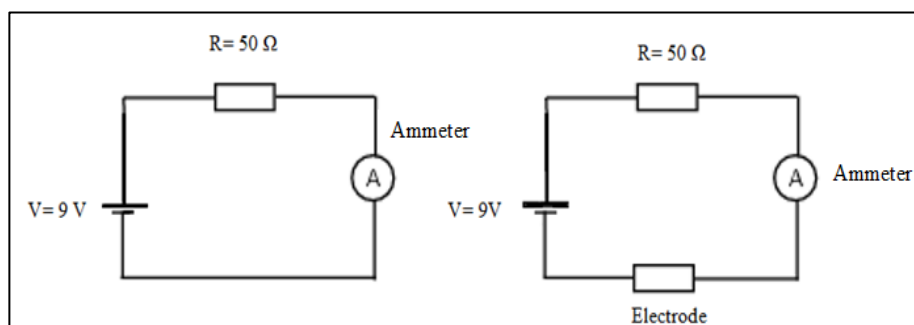

Figure 3. Simple circuit setup to measure electrode resistance and conductivity

Our second test was to test the actual performance of the proposed electrode as complementary components for the purpose of stimulation. Samples of the electrode are connected to the two ends of an actual stimulation device. In this work, the Medi Stim XP has been used. The Medi Stim XP stimulator

device with the preprogrammed stimulation is widely used as neuromuscular electrical nerve stimulation (NMES) for various muscular rehabilitations. The aim is to verify the signal strength as well as to measure the comfortability among the respondents.

To verify the signal outputs from the stimulator device, one of the preprogrammed settings on Medi Stim was selected. The signal coming out from the electrodes were then captured using the oscilloscope. In this verification test, besides comparing the output from the proposed electrode with the pre-gelled electrodes, signal produced for the proposed electrode with 2000 ppm silver was also compared with the electrodes with 5000 ppm silver concentration. The comfortability test was performed on 10 respondents aged between 23 and 26 years. The evaluation was observed based on the survey form filled by the respondents after the implementation of the stimulation devices.

4. EXPERIMENT RESULTS AND ANALYSIS

This section elaborates the experiment conducted. Initially, the experiments verify the conductivity of the electrodes of different layers of 2000 ppm silver added into PEDOT: PSS with both annealed and non-annealed process. Then, the steps are repeated for the 5000 ppm silver added into PEDOT: PSS with annealed and non-annealed process. This is to identify which concentration of SilverSol™ Silver to be used for the designated dry flexible electrode. A comparison between conventional electrodes and the designated electrodes as well as the comfortability test of the designated electrodes will also be discussed in this section.

4.1. Conductivity Test

The PEDOT: PSS is mixed with the five different amount of silver as a conductive ink for the electrodes. The ink is then being printed onto the 1 cm² polyester cotton fabrics with five different layers. The electrodes are then connected to the circuit as shown in Figure 3.3 and the current pass through the circuit is measured. The measured value for fixed resistor in this experiment is 51.5 Ω while the measured current pass through the circuit without any electrode is 93.60 mA.

4.1.1. PEDOT:PSS with 2000 ppm concentration of SilverSol™ Silver

Table 2 shows the electric current measured when the PEDOT: PSS mixed with the five different volumes of 2000 ppm of the silver and printed with five different layers onto the fabric substrates. Since the area of the electrodes and length of the electrodes is 1cm² and 1 cm respectively, the resistivity of the electrode is equal to the resistance value measured by using Ohm's Law. Hence, the conductivity of the electrodes calculated is tabulated in Table 3.

Table 2. Electric current measured for PEDOT: PSS mixed with 2000 ppm SilverSol™

PEDOT:Ag	Electric Current Measured (mA)				
	1 Layer	2 Layers	3 Layers	4 Layers	5 Layers
3 ml : 1 ml	1.42	2.34	6.48	8.45	14.55
3 ml : 2ml	2.04	5.43	7.61	11.88	17.27
3 ml : 3ml	2.67	3.85	9.09	14.58	17.77
3 ml : 4ml	3.49	5.4	11.54	16.6	18.86
3 ml : 5ml	5.8	8.54	15.12	19.47	19.39

Table 3. Conductivity calculated for PEDOT: PSS mixed with 2000 ppm SilverSol™

PEDOT:Ag	Conductivity Measured (S/cm ²)				
	1 Layer	2 Layers	3 Layers	4 Layers	5 Layers
3 ml : 1 ml	0.16	0.26	0.72	0.93	1.61
3 ml : 2ml	0.23	0.60	0.85	1.32	1.92
3 ml : 3ml	0.30	0.43	1.01	1.61	1.97
3 ml : 4ml	0.39	0.60	1.28	1.85	2.08
3 ml : 5ml	0.64	0.95	1.67	2.17	2.17

From the results, we can conclude that the conductivity of the electrode increases as the volume of the silver as well as the number of ink layers deposited on the substrates increases. There is shunt drop in the resistivity when the same volume of PEDOT:PSS and silver is used as the conductive ink for the electrodes due to the electrodes are not cracked as compared when the higher volume of the PEDOT:PSS used. There is no much difference in resistivity when 5 layers of ink are deposited onto the substrates.

For the electrodes with the 2000 ppm silver used and the electrodes tested under the annealing process, there are sudden drop of the conductivity when 5 ml silver being added to the PEDOT:PSS and the

ink is applied with 5 layers. This is happen because the water in the ink is not fully evaporated. Moreover, after the electrodes being annealed, the conductivity of the electrodes decreased due to the conductive ink being cracked. Steady increase of the conductivity when equal volume of the PEDOT: PSS and silver is used.

4.1.2. PEDOT: PSS with 5000 ppm concentration of SilverSol™ Silver

Table 4 represents the electric current measured when the PEDOT: PSS mixed with the five different volumes of 5000 ppm of the silver and printed with five different layers onto the fabric substrates. The same cases with 2000 ppm silver, the resistivity of the electrode is equal to the resistance value measured by using Ohm's Law. Hence, the conductivity of the electrodes calculated is depicted in Table 5.

Table 4. Electric current measured for PEDOT: PSS mixed with 5000 ppm SilverSol™

PEDOT:Ag	Electric Current Measured (mA)				
	1 Layer	2 Layer	3 Layer	4 Layer	5 Layer
3 ml : 1 ml	2.19	7.27	11.87	24.84	28.56
3 ml : 2ml	11.38	16.82	21.45	26.91	44.3
3 ml : 3ml	22.21	33.23	40.2	53.9	61.8
3 ml : 4ml	24.14	33.29	42.5	54.5	42.1
3 ml : 5ml	24.08	29.83	35.06	45	46.9

Table 5. Conductivity calculated for PEDOT: PSS mixed with 5000 ppm SilverSol™

PEDOT:Ag	Conductivity Measured (S/cm ²)				
	1 Layer	2 Layer	3 Layer	4 Layer	5 Layer
3 ml : 1 ml	0.24	0.81	1.32	2.76	3.17
3 ml : 2ml	1.27	1.87	2.38	2.99	4.92
3 ml : 3ml	2.47	3.69	4.47	5.99	6.87
3 ml : 4ml	2.68	3.70	4.72	6.06	4.68
3 ml : 5ml	2.68	3.31	3.90	5.00	5.21

The conductivity of the electrodes when the 3 ml volume of 5000 ppm silver being added to the PEDOT: PSS, the conductivity is higher as compared to when 5 ml silver being added to the PEDOT: PSS. Moreover, sudden drop of the conductivity when 4 ml silver was being used along with the PEDOT: PSS as the conductive layer of the electrodes. These were due to the non-uniform dispersion of the silver in the solution of the ink when a different volume is used for the mixing with PEDOT: PSS.

Based on the result of the annealed electrodes using 5000 ppm concentration of the silver, again it shows that equal volume of the PEDOT: PSS and silver yield the highest conductivity among other different mixtures of the electrodes. This is because uniform dispersion of the silver in the solution of the ink helps for the better path of the electron movement across the electrodes for a better conductivity.

4.1.3. PEDOT:PSS with 5000 ppm and 2000 ppm concentration of SilverSol™ Silver

From the experiments conducted, it was observed that the conductivity of the electrodes increases as the number of layers increases. The experiment results indicated that the conductivity of the electrodes with equal volume of both PEDOT: PSS and silver solution i.e. 3 ml silver, is higher when compared to volume of 5 ml silver solution added to 3 ml PEDOT: PSS. Figure 4 shows the conductivity of the electrodes with equal volume of PEDOT: PSS and silver solution. When the volume of PEDOT: PSS is higher than the silver solution, the electrodes are easily cracked losing its conducting property. In contrast, if the volume of silver solution is higher than PEDOT: PSS, the ink solution is not fully evaporated resulted in non-uniform dispersion of the silver in the inks. The graph also clearly portrays that the conductivity of the electrodes are higher when 5000 ppm silver solution is used as compared to the 2000 ppm solution. This is largely because of the 5000 ppm silver solution contain a higher number of silver particles than the 2000 ppm solution. Tabulated conductivity measurement in Table 6 and Table 7 show that the conductivity of the proposed electrode was further enhanced by a post-treatment process i.e. the annealing process.

Table 6. Conductivity measured for PEDOT: PSS mixed with 2000 ppm silver concentration with post-treatment (annealed)

PEDOT:Ag	Conductivity Measured (S/cm ²)				
	1 Layer	2 Layer	3 Layer	4 Layer	5 Layer
3 ml : 1 ml	0.18	0.87	0.89	1.25	1.90
3 ml : 2ml	0.54	0.95	1.31	1.65	2.30
3 ml : 3ml	0.64	1.06	1.58	1.96	2.44
3 ml : 4ml	0.96	1.10	1.74	2.38	2.55
3 ml : 5ml	0.45	1.11	2.35	3.82	3.12

Table 7. Conductivity measured for PEDOT: PSS mixed with 5000 ppm silver concentration with post-treatment (annealed)

PEDOT:Ag	Conductivity Measured (S/cm ²)				
	1 Layer (S/cm)	2 Layer (S/cm)	3 Layer (S/cm)	4 Layer (S/cm)	5 Layer (S/cm)
3 ml : 1 ml	0.37	0.90	1.45	2.91	3.68
3 ml : 2ml	1.64	2.20	2.56	3.25	5.71
3 ml : 3ml	3.50	3.93	4.41	6.42	6.90
3 ml : 4ml	4.81	4.88	5.01	6.47	4.89
3 ml : 5ml	4.78	4.91	5.62	6.46	6.58

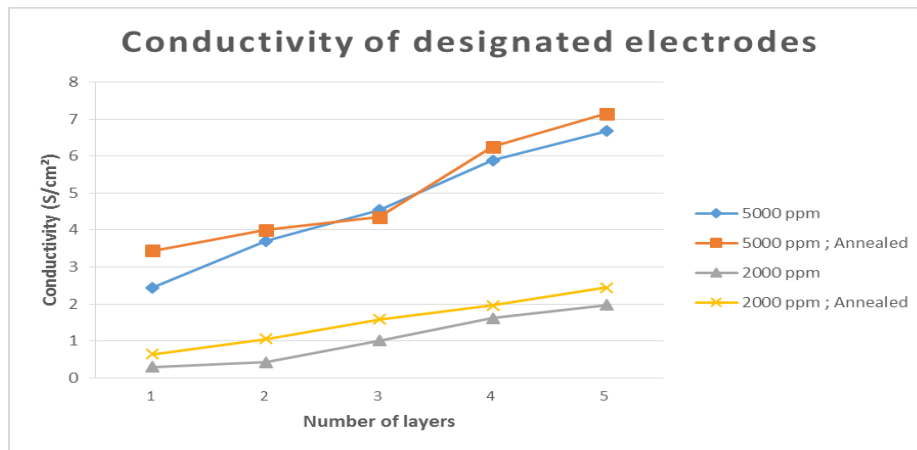

Figure 4. Conductivity of electrodes

4.2. Comparison against Pre-gelled Electrodes

The proposed electrodes and the commercialized pre-gelled electrodes were connected to the oscilloscope to obtain the signal as shown in Figure 5. The yellow and blue signal in Figure 5(a) represent the output signal produced by the pre-gelled and proposed electrode using the 2000 ppm silver concentration respectively. The signal produced by the proposed electrode has little added noise as compared to the signal of pre-gelled electrodes. The noise might be produced due to the non-uniform dispersion of the silver in the solution of the PEDOT: PSS. Moreover, the absence of the electrolyte gel might be one of the reasons that causes the electron to not spread uniformly across the attached surface. For the designated electrodes, the sweats produced due to perspiration will act as the electrolyte gel.

Meanwhile, the blue signal Figure 5(b) shows the signal obtained from the proposed designated electrodes using the 5000 ppm silver solution. The signal produced has lower noise as compared to the noise produced by the electrodes with 2000 ppm silver concentration. This is apparent since the 5000 ppm silver concentration solution has higher conductivity rate.

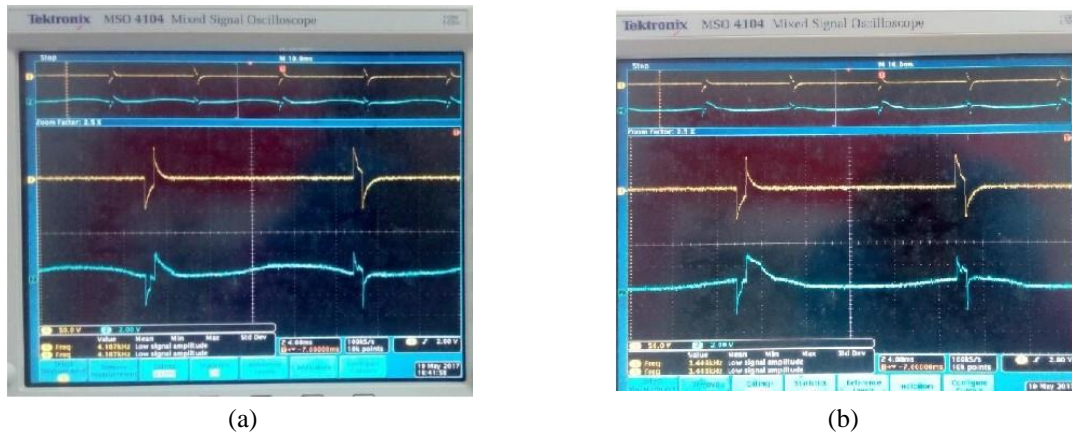

Figure 5. Comparison between commercialized electrodes with designated electrodes
(a) 2000 ppm silver solution, (b) 5000 ppm silver solution

4.3. Comfortability Test

Figure 6 shows a prototype implementation for the new flexible dry electrode. The electrodes have been tested on 10 subjects of which are five males and five females with the age ranging between 23 and 26 years old. Among the 10 subjects, four of them have had experienced using the stimulation devices. The pre-gelled electrodes score 93 out of 100 comfortability test marks when the respondents were asked to rate the satisfactory level towards the stimulation devices implemented with the electrodes. All the respondents felt comfortable using the devices without feeling any pain and they are not sweating.

In contrast, the PEDOT: PSS and silver electrodes score a satisfactory level of 83 and 82 out of 100 for 5000 ppm solution and 2000 ppm respectively. Although all the respondents felt comfortable using these electrodes, an average of 2.5 of the respondents felt a slight pain during the stimulation process when applied with the new dry electrode. This pain might be because of the higher conductivity exhibit by the electrodes to the skin which cause higher amount of electrical charge being transmitted into the muscle. Since this experiment has utilized the same setting when comparing the three electrodes, this would mean that lower amplitude of stimulation signal for the proposed dry electrode is enough to produce the same stimulation level as a pre-gelled electrode. Hence, with further enhancement, the new flexible design might be able to open a new market window in the biomedical electrodes application.



Figure 6. Electrodes being implemented with the stimulation devices being to a respondent

5. CONCLUSION

This paper aimed to design a new flexible non-invasive electrode that can be used with any standard stimulation device for stimulus application. The PEDOT: PSS mixed with the silver solution was printed on polyester cotton fabrics by dispenser printing technique. Test has been conducted to examine the conductivity

of the proposed fabricated electrodes. The performances of the proposed electrodes were compared to the commercialized off-the-shelf electrodes by evaluating the output at the electrode as well as the satisfactory level and comfortability level of the end user. For future recommendation and development, another substances can be add up to ensure a uniform dispersion of the silver in the PEDOT: PSS that give a better transmission of the charges to the muscle for the best comfortability and reducing pain. Moreover, to be able to find an alternative material for the polyester cotton fabric which have a better washable capability and maintain its high conductivity characteristic after a number of wash is recommended also. Based on the result analyzed and discussed, it is proven that the new flexible dry electrodes have high conductivity and can produce a valid stimulus signal and can function like the standard commercialized electrodes.

REFERENCES

- [1] M. F. Azman, *et al.*, "The Effect of Electrical Stimulation in Improving Muscle Tone (Clinical)," *IEEE International Conference on Smart Instrumentation, Measurement and Applications (ICSIMA)*, Putrajaya, 2017.
- [2] Keyun C. L. R., *et al.*, "Fabrication of Micro-Needle Electrodes for Bio-Signal Recording by a Magnetization-Induced Self-Assembly Method," *Sensors*, 2014.
- [3] Elena F., *et al.*, "Preliminary technological assessment of microneedles-based dry electrodes for biopotential monitoring in clinical examinations," *Sensors and Actuators A: Physical*, pp. 177-186, 2012.
- [4] N. Meziane, *et al.*, "Dry electrodes for electrocardiography," *Physiological Measurement*, 2013.
- [5] A. W. Azman, *et al.*, "Enhancement of Electrode Design for Non-Invasive Stimulus Application," *IEEE International Conference on Smart Instrumentation, Measurement and Applications (ICSIMA)*, Putrajaya, pp. 1-6, 2017.
- [6] Bryan H., "Design of Electrodes for Efficient and Selective Electrical Stimulation of Nervous Tissue," 2015.
- [7] S. Fujita and Y. Kamei, "Electrical properties of polyimide with water absorption," *11th International Symposium on Electrets (ISE11)*, 2002.
- [8] S. N. Ibrahim, *et al.*, "Characterization of Screen Printed Ag-PDMS Flexible Electrode for Electrical Muscle Stimulation (EMS)," *Indonesian Journal of Electrical Engineering and Informatics (IJEI)*, vol/issue: 5(4), pp. 295-303, 2017.
- [9] Cihun S. A. G., *et al.*, "Development of a Flexible Non-Metal Electrode for Cell Stimulation and Recording," *Sensors*, 2016.
- [10] Zhiheng Z., *et al.*, "PEDOT-based composites as electrode materials for supercapacitors," UK, 2015.
- [11] Khan S., *et al.*, "Bacterial Cellulose-poly(3,4-ethylenedioxythiophene)-poly(styrenesulfonate) Composite For Optoelectronic Applications," *Carbohydrate Polymers*, 2015.
- [12] Nano Silver Manufacturing Sdn Bhd. (2004, June) SilverSol™. [Online]. <http://www.nanosilver.com.my/>
- [13] J. Vaithilingam, *et al.*, "3D-inkjet Printing of Flexible and Stretchable Electronics," Nottingham, 2015.