

Dual Input Z-Source Inverter Fed PMSM Based Renewable Energy

V. Karthikeyan

Department of Electrical and Electronics Engineering (Marine), AMET University, Chennai

Article Info

Article history:

Received Oct 19, 2017

Revised Dec 25, 2017

Accepted Jan 18, 2018

Keywords:

Direct Torque Control (DTC)

Permanent Magnet

Synchronous Motor (PMSM)

Photovoltaic (PV)

Z Source Inverter (ZSI)

ABSTRACT

The proposed paper produces the high gain and low harmonic content in the permanent magnet synchronous motor fed Z-source inverter. The hybrid solar and fuel-based motor produces more power by using the direct torque control. The control based PMSM fed inverter for continuous power production. The dc bus voltage is regulated by using the DTC based PMSM. The speed of a permanent magnet synchronous motor is regulated, and the proposed DTC is minimizing the torque and flux ripple. In order to produce maximum power at the dc link and also improve the performance of PMSM in Matlab/ Simulink software.

Copyright © 2018 Institute of Advanced Engineering and Science.
All rights reserved.

Corresponding Author:

V. Karthikeyan,
Department of Electrical and Electronics Engineering (Marine),
AMET University,
Chennai.

1. INTRODUCTION

The permanent magnet synchronous motor is used in many application, torque response and high performance operation. Simple DTC algorithm with predetermined switching frequency for PMSM based on SPWM method is planned to diminish the flux and torque wave and lessen the calculation time and requirement of a powerful sufficient to bring out the real-time algorithm [1]-[4].

2. BACKGROUND

An impedance system offers a competent means of power transfer between source and load in a broad range of electric-power conversion applications (dc-dc, dc-ac, ac-dc, ac-ac), particularly for alternating sources like fuel cells, photovoltaic, and also wind turbines [5]-[7].

The problem of improving the behavior of a direct torque controlled induction machine and also of PMSM, especially by reducing the torque and flux ripples and by imposing the average switching frequency of the Voltage-Source Inverter (VSI). Z-Source inverter becomes a popular choice for boosting up the voltage generated by the renewable sources for different applications [8]-[10]. Although the conventional ZSI provides infinite increasing theoretically but practically it is limited. Further for more boosting factor, shoot-through duty ratio provided to ZSI has to be high. But the modulation index decreases and the voltage stress across the switch increases with high shoot-through [11].

The advanced solar and fuel based Z-source inverter for high power and also reduce the harmonics. The direct torque control of PMSM is designed for improving the performance of the motor and to reduce the torque ripple [12]. The input of ZSI has from the solar and fuel, and the supply of renewable energy are connected to the Z-source converter by using the switch. The inverter is connected to the motor for high speed and high efficiency of the system [13].

3. THE PROBLEM

In conventional method has additional dc-dc converter for increase the voltage gain. The proposed method has neglect the dc-dc converter and utilizes the Z source inverter for increasing the voltage.

4. PROPOSED SOLUTION

4.1. Photovoltaic System

The output of the PV has depends on the semiconductor material and irradiation and temperature. The PV model is shown in Figure 1. The diode equation of PV module is

$$I_{dio} = I \left(1 - \exp \frac{qv}{KaT} \right)$$

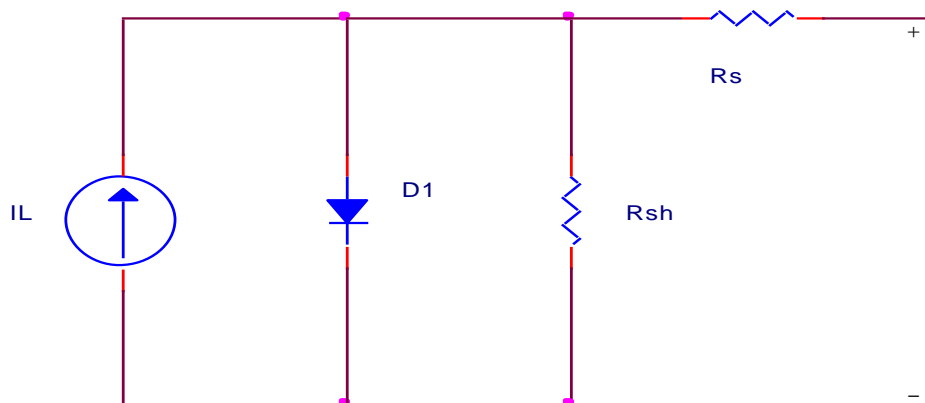

Figure 1. Circuit Diagram of PV model

Table 1. Parameters of Single Diode PV Cell at Operating Condition

S.No	Specification	Values
1	Open Circuit Voltage (V_{ocn})	70V
2	Short Circuit Current (I_{sc})	17A
3	Total no of Cells in parallel (N_p)	1
4	Total no of Cells in series (N_s)	6
5	Boltzman constant (K)	1.3805×10^{-23} J/K
6	Electron charge (q)	1.6×10^{-19} C
7	Output Current of PV (I_{pv})	120A

4.2. Fuel Cell

Fuel cell energy is also called as an electro-chemical cell, which exhibits at the similar time and directly converts the chemical energy of fuel cell and an oxidant to electrical energy by effort for fundamentally based electrode and electrolyte system [14].

4.3. Z-Source Inverter

The Z-source inverter uses passive elements for improving the voltage gain without using a transformer. The Z-source inverter cannot use the switch and to reduce the controller. The proposed converter has produced the continuous output and also ripples free current and voltage of ZSI [15]. The block diagram is shown in Figure 2.

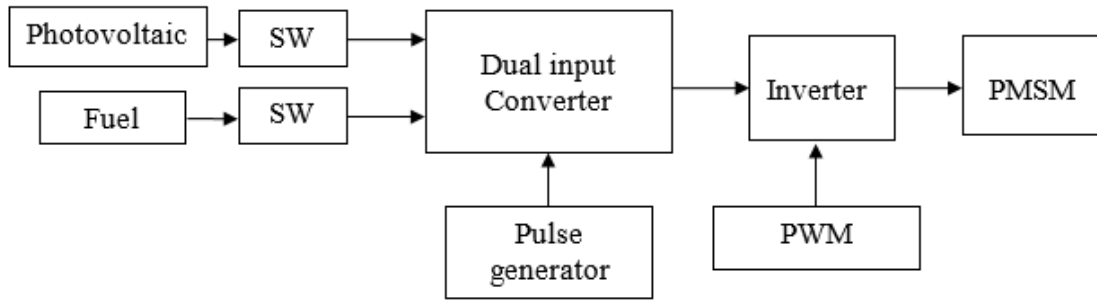

Figure 2. Block Diagram of Proposed Method

4.4. PMSM

The direct torque control of PMSM is to improve the performance of the motor. The speed and torque of a PMSM are to reduce the ripple and produce the speed regulation.

Table 2. Motor Specification

Motor Specification	
Rated voltage(V)	50
Rated Current(A)	15A
Nominal speed (rpm)	600
Stator Resistance()	0.19
Stator Inductance(mH)	0.835
Rotor moment of inertia J(kg.m ²)	1.9959μ

5. SIMULATION RESULTS

The overall diagram of proposed method is shown in Figure 3. The PV voltage and current waveform are shown in Figure 4. The dc link voltage is shown in Figure 5. The stator voltage and current are shown in Figure 6. The speed of a PMSM is shown in Figure 7.

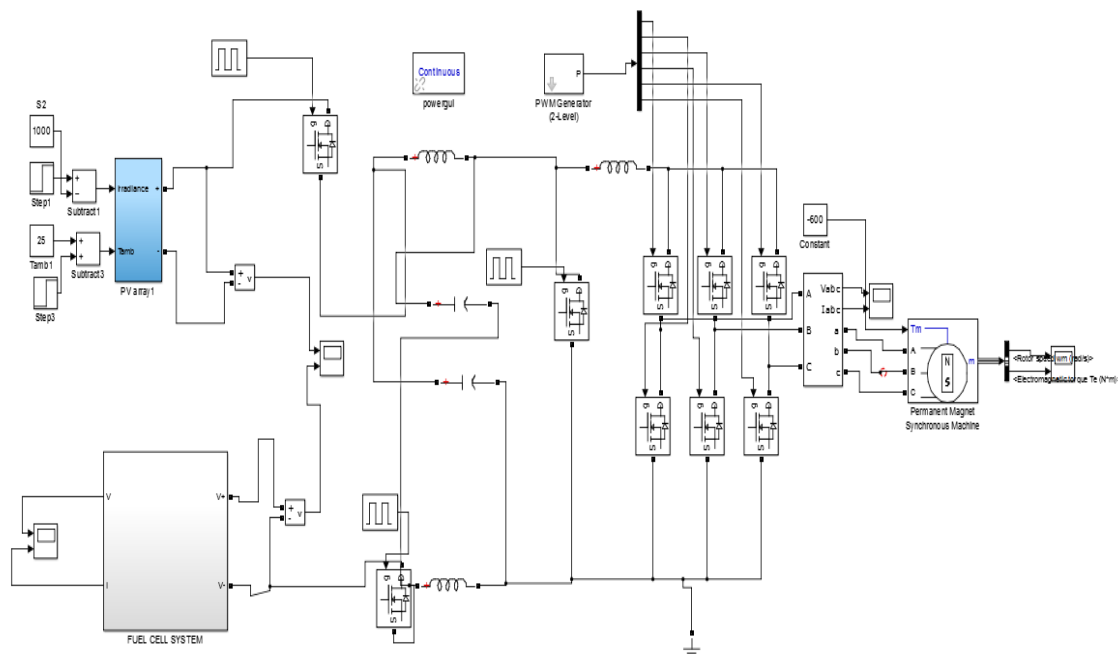

Figure 3. Overall Proposed Simulation Circuit Method

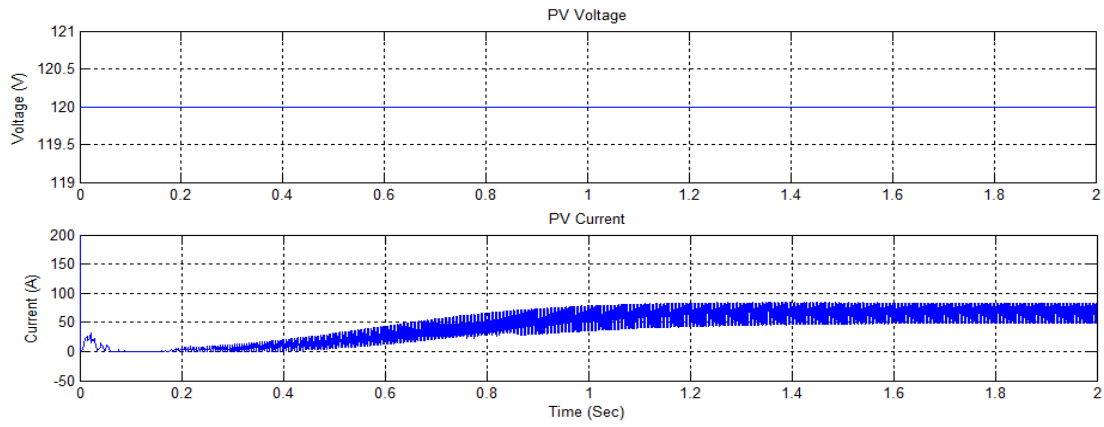

Figure 4. PV Voltage and Current Waveform

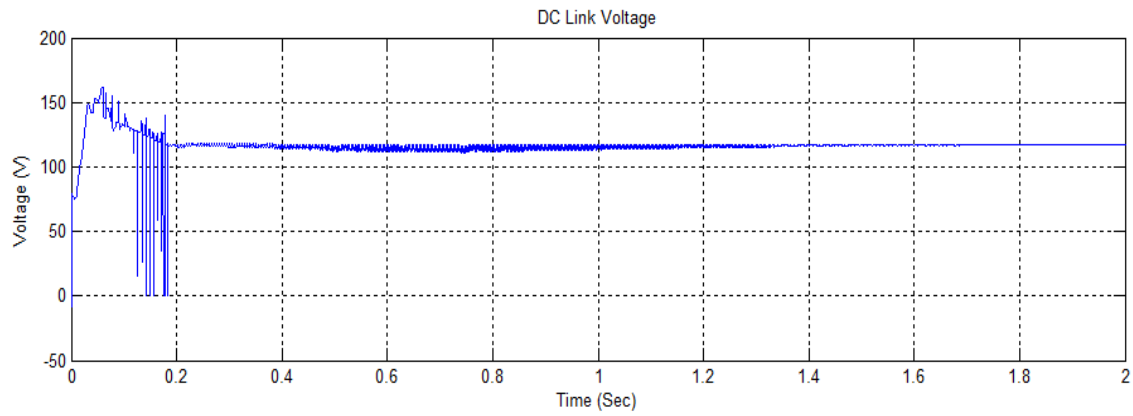

Figure 5. DC Link Voltage

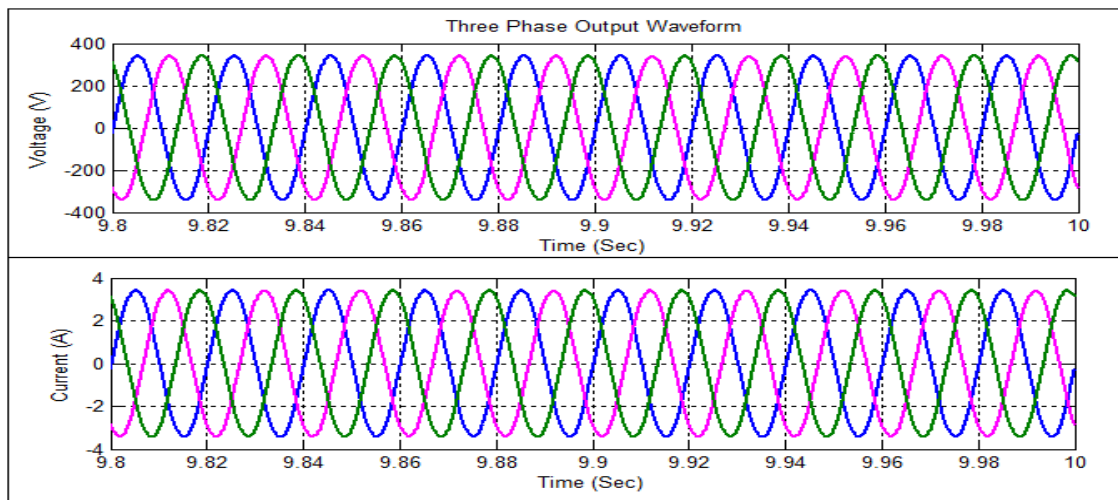

Figure 6. Stator Voltage and Current Waveform

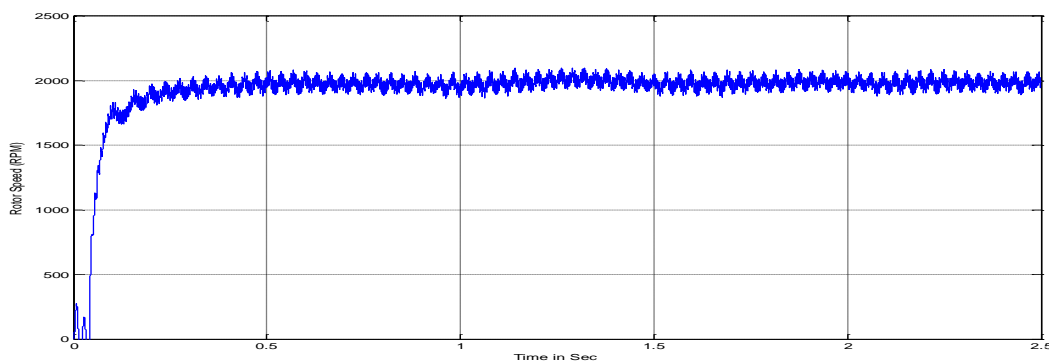

Figure 7. Speed of an PMSM

6. CONCLUSION

The proposed PMSM fed ZSI for solar and fuel renewable energy. The performance of the PMSM is improved, and the speed and torque are regulated. The dc link voltage is maintained by using direct torque control. The study and simulation results explain the input dc supply can distribute power to the load independently or simultaneously, as the failure of each contribution sources doesn't worry the other's operation. Two input sources can have unique characteristics and voltage. Also, converter controls output power with only one active switch which can reduce cost and develop the reliability.

REFERENCES

- [1] Mandal B., *et al.*, "Switched Capacitor Z-Source Inverter," *IEEE 1st International Conference on Power Electronics, Intelligent Control, and Energy Systems*, pp. 1-6, 2016.
- [2] Deng W., *et al.*, "Series Z-source and nine-switch dual-output inverter stage two-stage matrix converter," in *IET Power Electronics*, vol/issue: 10(2), pp. 143-150, 2017.
- [3] Battiston A., *et al.*, "Efficiency Improvement of a Quasi-Z-Source Inverter-Fed Permanent-Magnet Synchronous Machine-Based Electric Vehicle," in *IEEE Transactions on Transportation Electrification*, vol/issue: 2(1), pp. 14-23, 2016.
- [4] Ahmed T. and Mekhilef S., "Semi-Z-source inverter topology for grid-connected photovoltaic system," *IET Power Electronics*, vol/issue: 8(1), pp. 63-75, 2015.
- [5] Mangu B. and Fernandes B. G., "Multi-input transformer coupled DC-DC converter for PV-wind based stand-alone single-phase power generating system," *IEEE Energy Conversion Congress and Exposition (ECCE)*, Pittsburgh, PA, pp. 5288-5295, 2014.
- [6] Peng F. Z., *et al.*, "Maximum boost control of the Z-Source Inverter," *IEEE Trans. Power Electron*, vol/issue: 20(4), pp. 833-838, 2005.
- [7] K. Yu, *et al.*, "Space Vector Pulse-width Modulation Theory and Solution for Z-source Inverters with Maximum Constant Boost Control," *Int. J. Circ. Theory Appl.*, vol/issue: 42(2), pp. 127-145, 2014.
- [8] Shajith A. U. and Kamaraj V., "Z-Source Inverter with Space Vector PWM Algorithm for High Voltage Gain," *ARPN Journal of Engineering and Applied Sciences*, vol/issue: 6(6), 2011.
- [9] Thirumavalavana S., *et al.*, "Studies on Hall Effect and DC conductivity measurements of semiconductor thin films prepared by chemical bath deposition (CBD) method," *Journal of Nano-and Electronic Physics*, vol/issue: 7(4), pp. 4024-1, 2015.
- [10] Kumar P. S., *et al.*, "Pull-in voltage study of various structured cantilever and fixed-fixed beam models using COMSOL multi physics," *Indian Journal of Science and Technology*, vol/issue: 8(14), 2015.
- [11] Bavitra K., *et al.*, "The high efficiency renewable PV inverter topology," *Indian Journal of Science and Technology*, vol/issue: 8(14), 2015.
- [12] Ponshanmugakumar A., *et al.*, "Solar driven air conditioning system integrated with latent heat thermal energy storage," *Indian Journal of Science and Technology*, vol/issue: 7(11), pp. 1798-1804, 2015.
- [13] R. Aziz, *et al.*, "Thermal Modelling for Permanent Magnet Synchronous Machine (PMSM)," *International Journal of Power Electronics and Drive Systems (IJPEDS)*, vol/issue: 8(4), 2017.
- [14] R. Palanisamy and K. Vijayakumar, "Wind-PV Hybrid Energy Source Fed Three Level NPC with Quasi Z Source Network," *International Journal of Power Electronics and Drive Systems (IJPEDS)*, vol/issue: 8(3), 2017.
- [15] L. Sagar and B. Sarvesh, "Performance Analysis of Fuzzy Based Sliding Mode and Self-Tuning Controls of Vector Controlled Induction Motor Drive," *IJMSR*, vol/issue: 9(1), 2017.