

## A High Frequency Converter for EV Application

G. Kannan

Centre for Non-destructive Evaluation, AMET University, Chennai-603 112

---

### Article Info

#### Article history:

Received Jun 9, 2017

Revised Nov 20, 2017

Accepted Dec 11, 2017

---

#### Keywords:

DC-DC Converter

Electrical Vehicle Application

High Frequency

MATLAB

---

### ABSTRACT

An electrical vehicle (EV) is advancing as alternative power trains for green transportation. The DC-DC converter for auxiliary power supply of electric loads. In this paper presented a new topology of high frequency converter for electric vehicle was proposed. This converter has to be capable of handling the energy transfer from the 28V DC bus and the 550 high voltage DC bus (used for the electric traction). The control strategy is phase shift of the full bridge converter. Using this topology we reduce the switching losses. Conventional converter at two levels of voltage by only one full bridge converter using two planar transformers in high frequency the primary are coupled in parallel and the secondary are in series. We minimized the size and the weight of the converter. The high frequency converter advantages in terms of cost, efficiency, flexibility, and increased due to the possibility of easy synchronous rectification implementation.

*Copyright © 2018 Institute of Advanced Engineering and Science.  
All rights reserved.*

---

### Corresponding Author:

G. Kannan,

Centre for Non-destructive Evaluation,

AMET University, Chennai-603 112.

---

### Nomenclature

V: Voltage of fuel cell

$e I$ : Output Current of the fuel cell

$p r L$ : Resonant Inductor

$p r C$ : Resonant capacitor

$L_{p r i t}$ : Current of resonant inductor

$C_{p r i t}$ : Current in the resonant capacitor

$p i t$ : Primary current of planar transformer

$p v t$ : Primary voltage of the transformer

$s i t$ : Secondary Current of the transformer

$s v t$ : Secondary voltage of the transformer

$c h I$ : Load Current

$c h V$ : Load Voltage

$I$ : Output current bridge

$K i t$ : Current in the transistor  $i$

### 1. INTRODUCTION

Single source renewable energy based buck boost converters cannot supply a load or a drive if produced output from source is very less. Hence if more than one source is used for a converter operation of inverter is possible with either of the source. Power factor corrected power electronic converter has integrated one or more sources like solar with maximum power point tracking based boost converter and PMSG turbine based three phase sepic based power-factor-correction buck-boost rectifier can improve power factor and achieve less total harmonic distortion (THD) power converter.

### Problem Description

High voltage gain converters are required to handle voltage mismatch between low voltage energy storage systems and high voltage dc bus.

### Background

Fuel cell becomes the primary power source for the future generation of electric vehicles. Because of the very lack of an energy storage function in the fuel cell, it is required a relatively large DC-DC converter [1]. In sequence for a low voltage DC fuel cell to generate 550V DC voltage for motor vehicle, a DC-DC converter is needed to boost the fuel cell voltage to a level that can be converted to the desired DC output [2]. Many papers are published in this area. In this paper presented a, a high performance DC-DC converter is proposed to significantly reduce the current ripple of fuel cell, minimized the size and the weight, increase the efficiency and the lifetime of the fuel cell [3]. However this configuration required many fuel cells, what increases the cost of the system. Conventional converter describes it allows eliminating the ripple of the low-frequency current to feed a single load [4]. Conventional propose a multi-level DC-DC converter which feeds a residence with electrical energy through a fuel cell [5].

This solution needs multi fuel cell to achieve the high ac voltage. Today; there is no standard rating for the output voltage of a fuel cell. Nowadays fuel cells are producing dc voltages between 20V and 50V at full-load. When one of these fuel cells is connected to an inverter, they will not be able to give ac grid level voltages [6]. As shown in Figure 1, a boost converter is required to boost the voltage level for the inverter. This boost converter, used to boosting voltage, also it regulates the inverter input voltage and isolates the low and high voltage circuits. In this paper described that the PV inverter topology it is a high efficiency topology [7]. Firefly algorithm is presented in this paper in this algorithm used to generate the reactive power [8]. A Study on 3-phase Interleaved DC-DC Boost Converter Structure and Operation for Input Current Stress Reduction [9]. Hardware Implementation of Solar Based Boost to SEPIC Converter Fed Nine Level Inverter System [10]. Transformer less Voltage Quadrupler Based DC-DC Converter with Coupled Inductor and PI Filter for Increased Voltage Gain and Efficiency [11]. Solar photovoltaic array fed water pump driven by brushless dc motor using KY converter [12].

## 2. PROPOSED SYSTEM

To increase the life of the fuel-cell, it is necessary to have continuous output current and reduce its ripple. The converter topology proposed in Figure 1.

It allows:

- to obtain a high voltage of the output converter to reduce the ripple of the input current
- to reduce the converter losses and limit the current in the switches to a value which does not

Exceed the current produced by the fuel cell. The control strategy chosen is the phase shift control. This type of switching control consists of commanding successively (S1, S4), following by (S1, S4, S2, S3) and finally (S2, S3). Figure 2 illustrates the control signals of this four switches. Key features of the proposed DC/DC converter are the following:

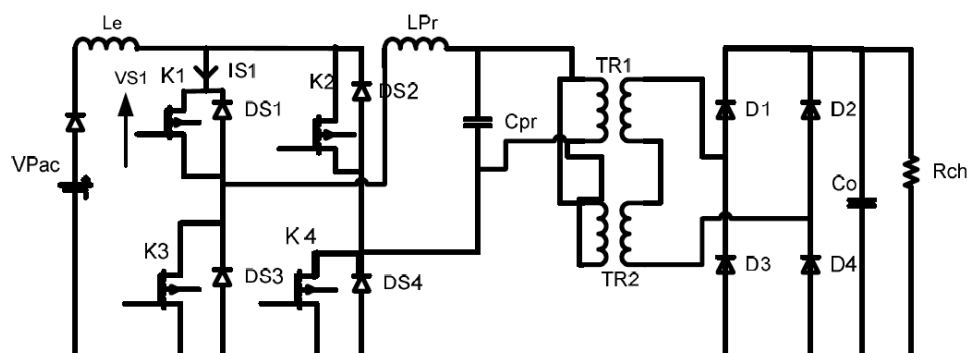

Figure 1. Circuit Diagram

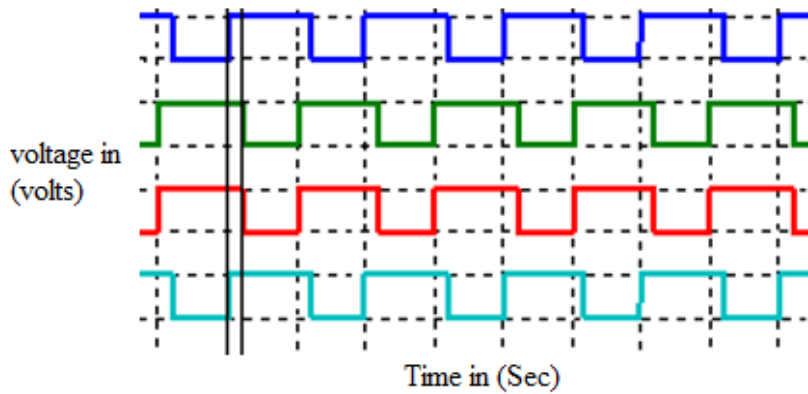

Figure 2. Switching Pulse

- The nominal voltage at the low voltage side of one input is 28 V and can vary from 20 to 30 V during charging and discharging. The nominal high-side voltage is 550 V,
- Nominal charging and discharging power is 1.5 kW.
- Switching frequency is 70 kHz.
- High frequency transformer is then used.

**PWM Modulation**

- The two PWM signals that are shifted by 180° have a duty cycle always higher than 50%.
- This is because an overlapping period where the two switches are simultaneously closed is necessary to charge the input inductances
- While necessarily avoiding a situation where both switches are open to avoid generating an unclamped situation for the input inductance that would lead to a dangerous over-voltage across the devices.
- Nevertheless, the transformer leakage inductance during the device turn-off transient causes an over voltage spike and a clamp circuit needs to be used.
- Conventional The active clamp we described before it will contain this energy, but it required to be controlled by an additional signal. The active clamp device is turned on immediately following the one of the dual device turn-off, and it is kept on for a fixed time of 500ns.

Table 1. Switching Table

Switch	K1	K2	K3	K4	DS1	DS2	DS3	DS4	D1	D2	D3	D4
STAGE	1	0	1	1	0	0	0	0	0	1	1	0
STAGE	1	1	1	1	0	0	0	0	0	1	1	0
STAGE	1	1	1	1	0	0	0	0	0	0	0	0
STAGE	1	0	0	1	0	1	1	0	0	0	0	0
STAGE	1	0	0	1	0	0	0	0	0	0	0	0
STAGE	1	0	0	1	0	0	0	0	1	0	0	1
STAGE	1	1	1	1	0	0	0	0	1	0	0	1
STAGE	1	1	1	1	0	0	0	0	0	0	0	0
STAGE	0	1	1	0	0	0	1	0	0	0	0	0
STAGE	1	0	0	1	1	0	0	0	0	0	0	0

The equivalent circuits for each stage are represented in the following figures.

**Modes of operation**

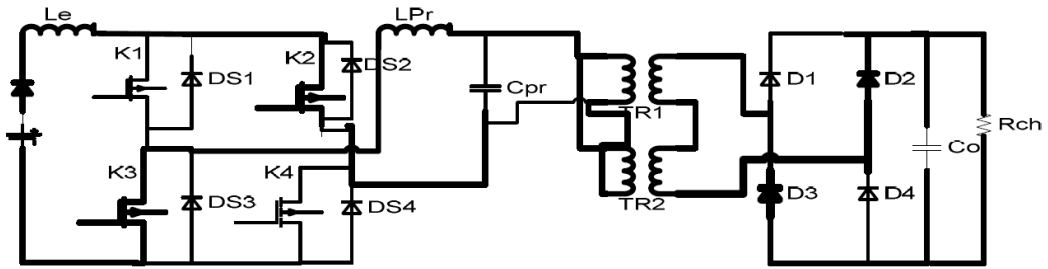

Figure 3. Mode 1

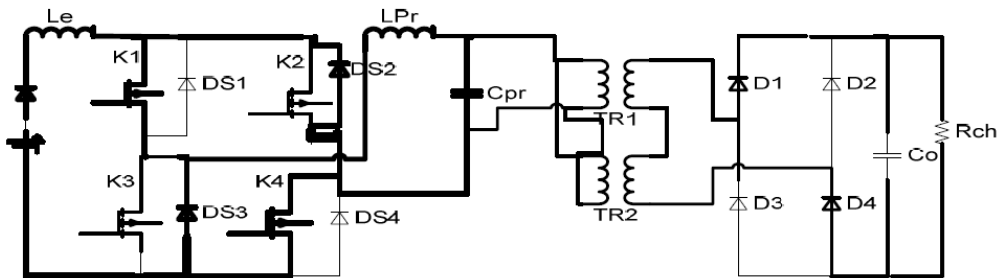

Figure 4. Mode 2

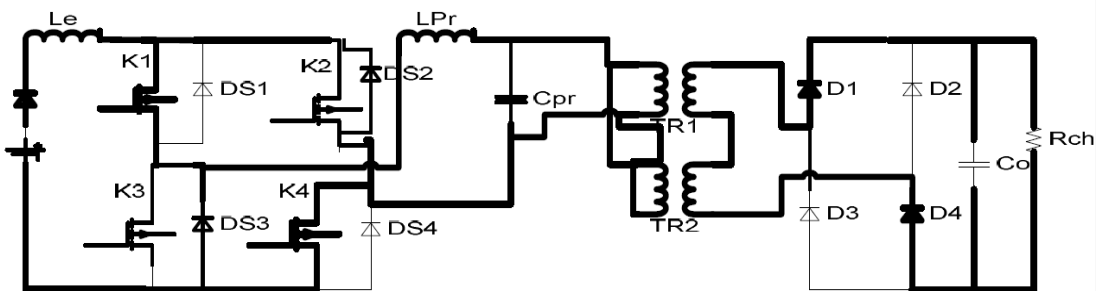

Figure 5. Mode 3

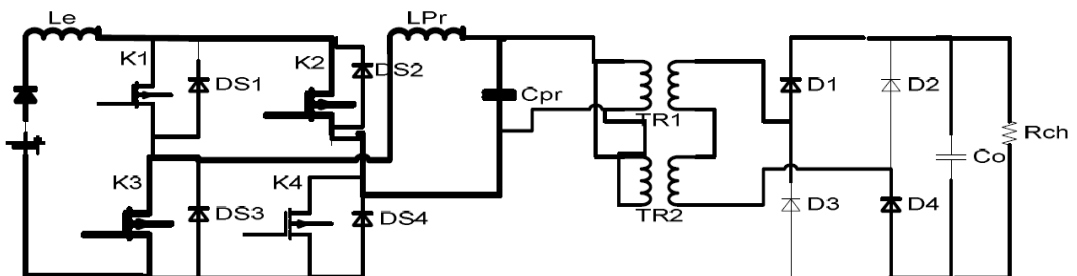

Figure 6. Mode 4

### 3. SIMULATION RESULTS AND DISCUSSIONS

In simulation, a resistive load is used. The converter is operating at 50 kHz with a duty cycle of 60%. The DC-DC converter simulation results are shown in Figure. The parameters utilized are presented as follows:  $24 V_{pac} = V$ ,  $L_{pr} = 0.45 \mu H$ ,  $C_{pr} = 1$

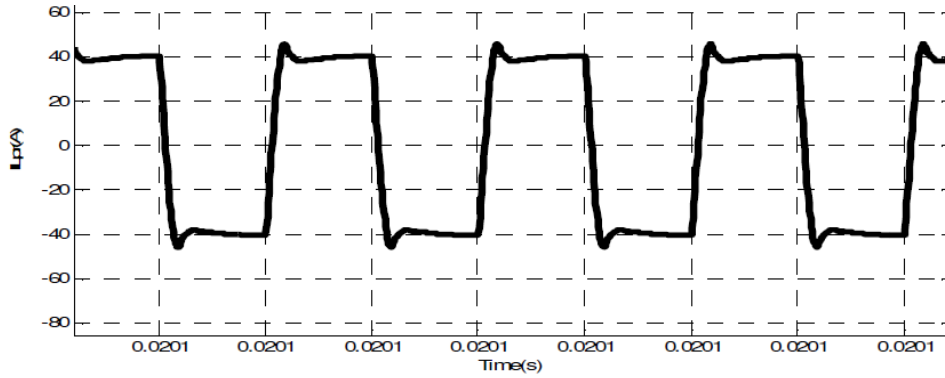

Figure 7. Current in Resonant Inductor

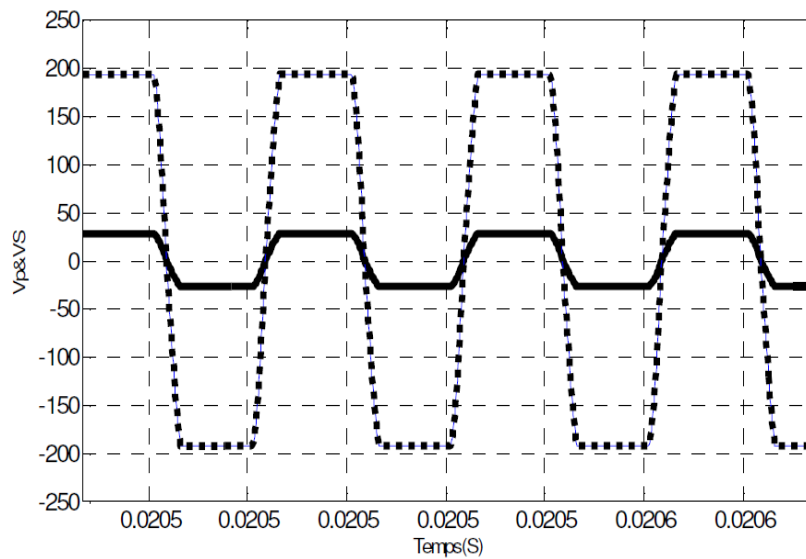

Figure 8. Voltages Primary and Secondary of the Transformer

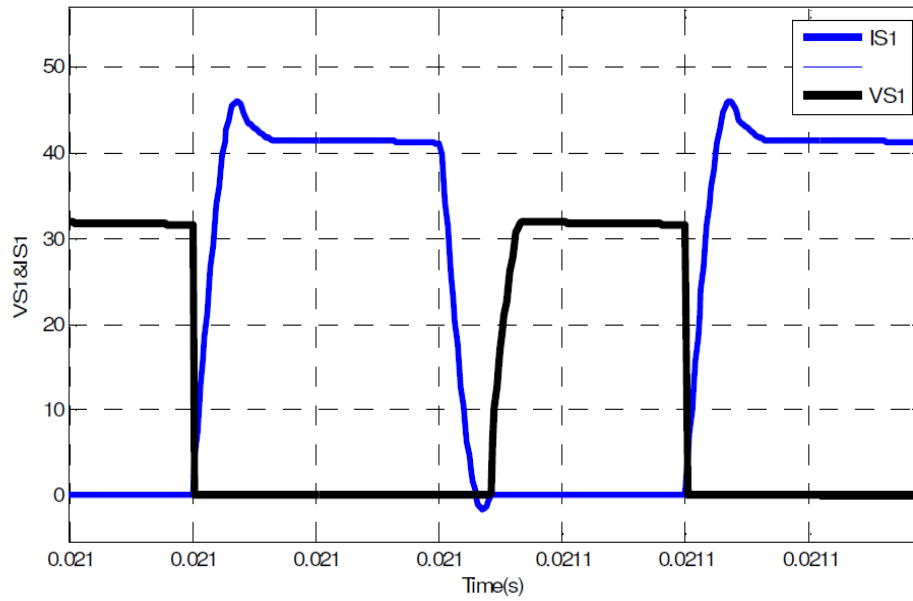

Figure 9. Voltage and Current in Switch 1

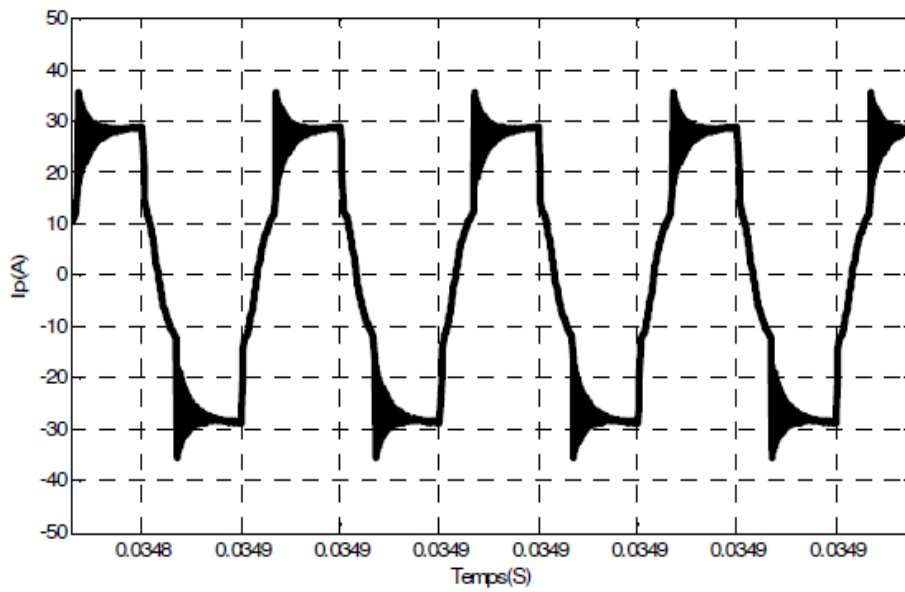

Figure 10. Primary Current of Transformer

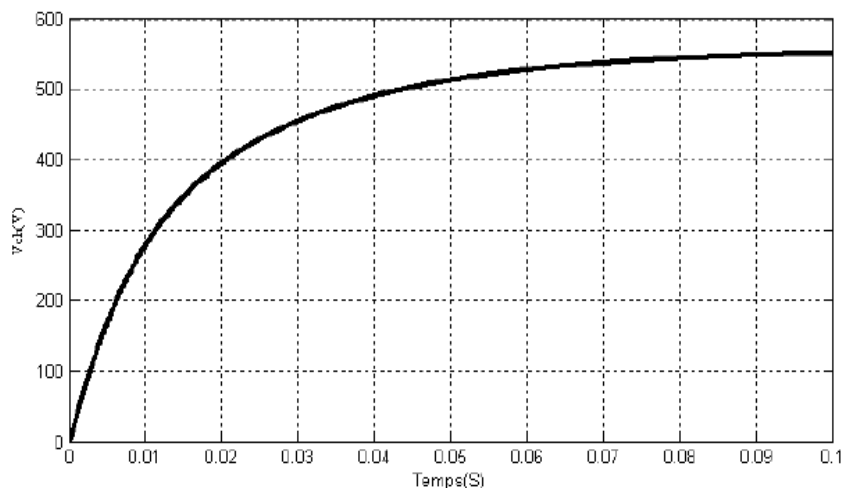

Figure 11. Output DC voltage

#### 4. CONCLUSION

This paper has been presented for electrical vehicle application in low cost fuel-cell converter the operation, features and design considerations were illustrated below. Simulation and results for the 1.2 kW, 500V AC. It is shown that the peak current of the DC-DC converter is controlled. At last we managed to realize a static converter which gives boost voltage from 28 v to 550 v .Winding of inductor (they are manually wound), what has for effect the obtaining of the values of the different inductances to those in the simulation - High-frequency single-phase Transformer (really it is not completed) - Vital leads, because at high frequency, we cannot neglect any more their influences.

#### REFERENCES

- [1] Agus Purwadi; Arwindra Rizqiawan; Deny Hariyanto; Jonathan Pribadi; Hilwadi Hindersah; Yanuarsyah Haroen, *Analysis of power converters for high frequency resonant inductive electric vehicle charging system*, 2016 3rd Conference on Power Engineering and Renewable Energy (ICPERE) Year: 2016
- [2] Zhenjin Pang; Xiaoyong Ren; Junlin Xiang; Qianhong Chen; Xinbo Ruan; Wu Chen, 2016, High-frequency DC-DC converter in electric vehicle based on GaN transistors, *IEEE Energy Conversion Congress and Exposition (ECCE)* Year: 2016
- [3] Djilali Hamza; Majid Pahlevaninezhad, 2014, Integrated capacitor for common-mode EMI mitigation applicable to high frequency planar transformers used in electric vehicles DC/DC converters, *IEEE Energy Conversion Congress and Exposition (ECCE)* Year: 2014
- [4] Majid Pahlevaninezhad; Djilali Hamza; Amish Servansing; Alireza Bakhshai; *An integrated EMI suppression Y-caps applicable to high frequency planar transformers in high power DC-DC converters used for electric vehicle*, Praveen Jain IECON 2012 - 38th Annual Conference on IEEE Industrial Electronics Society Year: 2012
- [5] Mahmoud M. Amin; Osama A. Mohammed, 2011, A three-phase high frequency semi-controlled battery charging power converter for plug-in hybrid electric vehicles, *IEEE Energy Conversion Congress and Exposition*, Year: 2011
- [6] Shishuo Zhao; Qiang Li; Fred C. Lee, 2017, *High frequency transformer design for modular power conversion from medium voltage AC to 400V DC*, *IEEE Applied Power Electronics Conference and Exposition (APEC)* Year: 2017.
- [7] Bavitra, K., Sinthuja, S., Manoharan, N. and Rajesh, S., 2015. The high efficiency renewable PV inverter topology. *Indian Journal of Science and Technology*, 8(14).
- [8] Kannan, G., Subramanian, D.P. and Shankar, R.U., 2015. Reactive power optimization using firefly algorithm. In *Power Electronics and Renewable Energy Systems* (pp. 83-90). Springer India.
- [9] Harimon, M. A., Ponniran, A., Kasiran, A. N., & Hamzah, H. H. (2017). A Study on 3-phase Interleaved DC-DC Boost Converter Structure and Operation for Input Current Stress Reduction. *International Journal of Power Electronics and Drive Systems (IJPEDS)*, 8(4).
- [10] Jasmine, D., & Gopinath, M. (2016). Hardware Implementation of Solar Based Boost to SEPIC Converter Fed Nine Level Inverter System. *International Journal of Power Electronics and Drive Systems*, 7(4).
- [11] Sujitha, C., Ravi, S., Diarra, B., & Chuma, J. (2016). Transformer Less Voltage Quadrupler Based DC-DC Converter with Coupled Inductor and PI Filter for Increased Voltage Gain and Efficiency. *International Journal of Power Electronics and Drive Systems*, 7(4).
- [12] Dinesh, B., Jaivinayagam, M., Udayakumar, M., & Syedismail, S. *SOLAR PHOTOVOLTAIC ARRAY FED WATER PUMP RIVEN BY BRUSHLESS DC MOTOR USING KY CONVERTER*.